

TMS320F/C240 DSP Controllers Reference Guide

Peripheral Library and Specific Devices

Literature Number: SPRU161C
June 1999



Printed on Recycled Paper

IMPORTANT NOTICE

Texas Instruments and its subsidiaries (TI) reserve the right to make changes to their products or to discontinue any product or service without notice, and advise customers to obtain the latest version of relevant information to verify, before placing orders, that information being relied on is current and complete. All products are sold subject to the terms and conditions of sale supplied at the time of order acknowledgement, including those pertaining to warranty, patent infringement, and limitation of liability.

TI warrants performance of its semiconductor products to the specifications applicable at the time of sale in accordance with TI's standard warranty. Testing and other quality control techniques are utilized to the extent TI deems necessary to support this warranty. Specific testing of all parameters of each device is not necessarily performed, except those mandated by government requirements.

CERTAIN APPLICATIONS USING SEMICONDUCTOR PRODUCTS MAY INVOLVE POTENTIAL RISKS OF DEATH, PERSONAL INJURY, OR SEVERE PROPERTY OR ENVIRONMENTAL DAMAGE ("CRITICAL APPLICATIONS"). TI SEMICONDUCTOR PRODUCTS ARE NOT DESIGNED, AUTHORIZED, OR WARRANTED TO BE SUITABLE FOR USE IN LIFE-SUPPORT DEVICES OR SYSTEMS OR OTHER CRITICAL APPLICATIONS. INCLUSION OF TI PRODUCTS IN SUCH APPLICATIONS IS UNDERSTOOD TO BE FULLY AT THE CUSTOMER'S RISK.

In order to minimize risks associated with the customer's applications, adequate design and operating safeguards must be provided by the customer to minimize inherent or procedural hazards.

TI assumes no liability for applications assistance or customer product design. TI does not warrant or represent that any license, either express or implied, is granted under any patent right, copyright, mask work right, or other intellectual property right of TI covering or relating to any combination, machine, or process in which such semiconductor products or services might be or are used. TI's publication of information regarding any third party's products or services does not constitute TI's approval, warranty or endorsement thereof.

Read This First

About This Manual

The purpose of this user's guide is to assist you, the hardware or software engineer, in developing applications using the TMS320C240/F240 digital signal processors (DSPs).

Throughout this book, the TMS320C240 and the TMS320F240 (with on-chip flash EEPROM) are generally referred to as the '240.

For more information about the '240 CPU and instruction set, see *TMS320C24x DSP Controllers, CPU and Instruction Set* (literature number SPRU160).

For known exceptions to the functional and emulation specifications for the '240, refer to *Enhancements and Exceptions for the 'F240 DSP Controller, Silicon Releases 1.1, 2.0, 3.1, and 3.2* (literature number SPRS066).

How to Use This Manual

The following table summarizes the '240 information contained in this manual (refer to the Table of Contents for a complete listing):

If you are looking for information about	Turn to
Digital I/O ports	Chapter 12, <i>Digital I/O Ports</i>
Dual 10-bit A/D converter	Chapter 7, <i>Dual 10-Bit Analog to Digital Converter (ADC) Module</i>
Event manager	Chapter 6, <i>Event Manager Module</i>
External memory interface	Chapter 11, <i>External Memory Interface</i>
PLL clock module	Chapter 4, <i>PLL Clock Module</i>
Serial communications interface	Chapter 8, <i>Serial Communications Interface (SCI) Module</i>
Serial peripheral interface	Chapter 9, <i>Serial Peripheral Interface (SPI) Module</i>
Watchdog and real-time interrupt module	Chapter 5, <i>Watchdog (WD) and Real-Time Interrupt (RTI) Module</i>

Notational Conventions

This document uses the following conventions:

- Program listings and program examples are shown in a special typeface.

Here is a segment of a program listing:

```

OUTPUT LDP    #6      ;select data page 6
        BLDD   #300, 20h ;move data at address 300h to 320h
        RET
    
```

- Hexadecimal numbers are represented with a lowercase letter *h* following the number. For example, 7400h or 743Fh.
- In syntax descriptions, the instruction is in a **bold typeface** and parameters are in an *italic typeface*. Portions of a syntax in **bold** must be entered as shown; portions of a syntax in *italics* describe the type of information that you specify. Here is an example of an instruction syntax:

BLDD *source, destination*

BLDD is the instruction and has two parameters, *source* and *destination*. When you use **BLDD**, the first parameter must be an actual data memory source address and the second parameter must be a destination address. A comma and a space (optional) must separate the two addresses.

- Square brackets, [], identify an optional parameter. If you use an optional parameter, specify the information within the brackets; do not type the brackets themselves. When you specify more than one optional parameter from a list, you separate them with a comma and a space. Here is a sample syntax:

BLDD *source, destination* [, **AR***n*]

BLDD is the instruction. The two required operands are *source* and *destination*, and the optional operand is **AR***n*. **AR** is bold and *n* is italic; if you choose to use **AR***n*, you must type the letters A and R and then supply a chosen value for *n* (in this case, a value from 0 to 7). Here is an example:

Information About Cautions

This book contains cautions.

This is an example of a caution statement.

A caution statement describes a situation that could potentially damage your software or equipment.

Related Documentation from Texas Instruments

The following books describe the 'F/C240 and related support tools. To obtain a copy of any of these TI documents, call the Texas Instruments Literature Response Center at (800) 477–8924. When ordering, please identify the book by its title and literature number. Many of these documents are located on the internet at <http://www.ti.com>.

TMS320F/C24x DSP Controllers CPU and Instruction Set Reference Guide (literature number SPRU160) describes the TMS320F/C24x 16-bit fixed-point digital signal processor controller. Covered are its architecture, internal register structure, data and program addressing, and instruction set. Also includes instruction set comparisons and design considerations for using the XDS510 emulator.

TMS320F243/F241/C242 DSP Controllers System and Peripherals Reference Guide (literature number SPRU276) describes the architecture, system hardware, peripherals, and general operation of the TMS320F243, 'F241, and 'C242 digital signal processor (DSP) controllers.

TMS320C240, TMS320F240 DSP Controllers (literature number SPRS042) data sheet contains the electrical and timing specifications for these devices, as well as signal descriptions and pinouts for all of the available packages.

TMS320F20x/F24x Embedded Flash Memory Technical Reference (literature number SPRU282) Describes the operation of the embedded flash EEPROM module on the TMS320F20x/F24x digital signal processor (DSP) devices and provides sample code that you can use to develop your own software.

TMS320C1x/C2x/C2xx/C5x Code Generation Tools Getting Started Guide (literature number SPRU121) describes how to install the TMS320C1x, TMS320C2x, TMS320C2xx, and TMS320C5x assembly language tools and the C compiler for the 'C1x, 'C2x, 'C2xx, and 'C5x devices. The installations for MS-DOS™, OS/2™, SunOS™, and Solaris™ systems are covered.

TMS320C1x/C2x/C2xx/C5x Assembly Language Tools User's Guide (literature number SPRU018) describes the assembly language tools (assembler, linker, and other tools used to develop assembly language code), assembler directives, macros, common object file format, and symbolic debugging directives for the 'C1x, 'C2x, 'C2xx, and 'C5x generations of devices.

TMS320C2x/C2xx/C5x Optimizing C Compiler User's Guide (literature number SPRU024) describes the 'C2x/C2xx/C5x C compiler. This C compiler accepts ANSI standard C source code and produces TMS320 assembly language source code for the 'C2x, 'C2xx, and 'C5x generations of devices.

TMS320C2xx C Source Debugger User's Guide (literature number SPRU151) tells you how to invoke the 'C2xx emulator and simulator versions of the C source debugger interface. This book discusses various aspects of the debugger interface, including window management, command entry, code execution, data management, and breakpoints. It also includes a tutorial that introduces basic debugger functionality.

TMS320C2xx Simulator Getting Started (literature number SPRU137) describes how to install the TMS320C2xx simulator and the C source debugger for the 'C2xx. The installation for MS-DOS™, PC-DOS™, SunOS™, Solaris™, and HP-UX™ systems is covered.

TMS320C2xx Emulator Getting Started Guide (literature number SPRU209) tells you how to install the Windows™ 3.1 and Windows™ 95 versions of the 'C2xx emulator and C source debugger interface.

XDS51x Emulator Installation Guide (literature number SPNU070) describes the installation of the XDS510™, XDS510PP™, and XDS510WS™ emulator controllers. The installation of the XDS511™ emulator is also described.

XDS522/XDS522A Emulation System Installation Guide (literature number SPRU171) describes the installation of the emulation system. Instructions include how to install the hardware and software for the XDS522™ and XDS522A™.

XDS522A Emulation System User's Guide (literature number SPRU169) tells you how to use the XDS522A™ emulation system. This book describes the operation of the breakpoint, tracing, and timing functionality in the XDS522A emulation system. This book also discusses BTT software interface and includes a tutorial that uses step-by-step instructions to demonstrate how to use the XDS522A emulation system.

XDS522A Emulation System Online Help (literature number SPRC002) is an online help file that provides descriptions of the BTT software user interface, menus, and dialog boxes.

JTAG/MPSD Emulation Technical Reference (literature number SPDU079) provides the design requirements of the XDS510™ emulator controller, discusses JTAG designs (based on the IEEE 1149.1 standard), and modular port scan device (MPSD) designs.

TMS320 DSP Development Support Reference Guide (literature number SPRU011) describes the TMS320 family of digital signal processors and the tools that support these devices. Included are code-generation tools (compilers, assemblers, linkers, etc.) and system integration and debug tools (simulators, emulators, evaluation modules, etc.). Also covered are available documentation, seminars, the university program, and factory repair and exchange.

TMS320 DSP Designer's Notebook: Volume 1 (literature number SPRT125) presents solutions to common design problems using 'C2x, 'C3x, 'C4x, 'C5x, and other TI DSPs.

TMS320 Third-Party Support Reference Guide (literature number SPRU052) alphabetically lists over 100 third parties that provide various products that serve the family of TMS320 digital signal processors. A myriad of products and applications are offered—software and hardware development tools, speech recognition, image processing, noise cancellation, modems, etc.

Related Technical Articles

The following technical articles contain useful information regarding designs, operations, and applications for signal-processing systems. These articles supplement the material in this book.

“A Greener World Through DSP Controllers”, Panos Papamichalis, *DSP & Multimedia Technology*, September 1994.

“A Single-Chip Multiprocessor DSP for Image Processing—TMS320C80”, Dr. Ing. Dung Tu, *Industrie Elektronik*, Germany, March 1995.

“Application Guide with DSP Leading-Edge Technology”, Y. Nishikori, M. Hattori, T. Fukuhara, R. Tanaka, M. Shimoda, I. Kudo, A. Yanagitani, H. Miyaguchi, et al., *Electronics Engineering*, November 1995.

“Approaching the No-Power Barrier”, Jon Bradley and Gene Frantz, *Electronic Design*, January 9, 1995.

“Beware of BAT: DSPs Add Brilliance to New Weapons Systems”, Panos Papamichalis, *DSP & Multimedia Technology*, October 1994.

“Choose DSPs for PC Signal Processing”, Panos Papamichalis, *DSP & Multimedia Technology*, January/February 1995.

“Developing Nations Take Shine to Wireless”, Russell MacDonald, Kara Schmidt and Kim Higden, *EE Times*, October 2, 1995.

- “Digital Signal Processing Solutions Target Vertical Application Markets”, Ron Wages, *ECN*, September 1995.
- “Digital Signal Processors Boost Drive Performance”, Tim Adcock, *Data Storage*, September/October 1995.
- “DSP and Speech Recognition, An Origin of the Species”, Panos Papamichalis, *DSP & Multimedia Technology*, July 1994.
- “DSP Design Takes Top-Down Approach”, Andy Fritsch and Kim Asal, *DSP Series Part III*, *EE Times*, July 17, 1995.
- “DSPs Advance Low-Cost ‘Green’ Control”, Gregg Bennett, *DSP Series Part II*, *EE Times*, April 17, 1995.
- “DSPs Do Best on Multimedia Applications”, Doug Rasor, *Asian Computer World*, October 9–16, 1995.
- “DSPs: Speech Recognition Technology Enablers”, Gene Frantz and Gregg Bennett, *I&CS*, May 1995.
- “Easing JTAG Testing of Parallel-Processor Projects”, Tony Coomes, Andy Fritsch, and Reid Tatge, *Asian Electronics Engineer*, Manila, Philippines, November 1995.
- “Fixed or Floating? A Pointed Question in DSPs”, Jim Larimer and Daniel Chen, *EDN*, August 3, 1995.
- “Function-Focused Chipsets: Up the DSP Integration Core”, Panos Papamichalis, *DSP & Multimedia Technology*, March/April 1995.
- “GSM: Standard, Strategien und Systemchips”, Edgar Auslander, *Elektronik Praxis*, Germany, October 6, 1995.
- “High Tech Copiers to Improve Images and Reduce Paperwork”, Karl Gutttag, *Document Management*, July/August 1995.
- “Host-Enabled Multimedia: Brought to You by DSP Solutions”, Panos Papamichalis, *DSP & Multimedia Technology*, September/October 1995.
- “Integration Shrinks Digital Cellular Telephone Designs”, Fred Cohen and Mike McMahan, *Wireless System Design*, November 1994.
- “On-Chip Multiprocessing Melds DSPs”, Karl Gutttag and Doug Deao, *DSP Series Part III*, *EE Times*, July 18, 1994.
- “Real-Time Control”, Gregg Bennett, *Appliance Manufacturer*, May 1995.
- “Speech Recognition”, P.K. Rajasekaran and Mike McMahan, *Wireless Design & Development*, May 1995.

“Telecom Future Driven by Reduced Milliwatts per DSP Function”, Panos Papamichalis, *DSP & Multimedia Technology*, May/June 1995.

“The Digital Signal Processor Development Environment”, Greg Peake, *Embedded System Engineering*, United Kingdom, February 1995.

“The Growing Spectrum of Custom DSPs”, Gene Frantz and Kun Lin, *DSP Series Part II, EE Times*, April 18, 1994.

“The Wide World of DSPs,” Jim Larimer, *Design News*, June 27, 1994.

“Third-Party Support Drives DSP Development for Uninitiated and Experts Alike”, Panos Papamichalis, *DSP & Multimedia Technology*, December 1994/January 1995.

“Toward an Era of Economical DSPs”, John Cooper, *DSP Series Part I, EE Times*, Jan. 23, 1995.

Trademarks

HP-UX is a trademark of Hewlett-Packard Company.

MS-DOS and Windows are registered trademarks of Microsoft Corporation.

OS/2, PC, and PC-DOS are trademarks of International Business Machines Corporation.

PAL® is a registered trademark of Advanced Micro Devices, Inc.

Solaris and SunOS are trademarks of Sun Microsystems, Inc.

320 Hotline On-line, TI, XDS510, XDS510PP, XDS510WS, XDS511, XDS522, and XDS522A are trademarks of Texas Instruments Incorporated.

Contents

1	Introduction	1-1
	<i>Summarizes the TMS320 family of products. Introduces the TMS320C24x DSP controllers and provides an overview of the '240 device.</i>	
1.1	TMS320 Family Overview	1-2
1.2	TMS320C24x Series of DSP Controllers	1-5
1.3	TMS320F/C240 Overview	1-7
2	TMS320F/C240 DSP Controller	2-1
	<i>Describes the TMS320F/C240 DSP Controller. Includes a device overview, pin-out diagram, memory map, and a discussion on interrupts.</i>	
2.1	TMS320F/C240 DSP Controller Overview	2-2
2.1.1	Architectural Overview	2-13
2.2	Memory Map	2-15
2.3	Peripheral Memory Map	2-17
2.4	Digital I/O and Shared Pin Functions	2-19
2.4.1	Description of Group1 Shared I/O pins	2-19
2.4.2	Description of Group 2 Shared I/O Pins	2-21
2.4.3	Digital I/O Control Registers	2-21
2.5	Interrupts	2-27
2.5.1	Resets	2-31
2.5.2	Non-Maskable Interrupts (NMI) — Hardware and Software	2-34
2.5.3	Interrupt Structure — Detailed Description	2-36
2.5.4	Interrupt Structure — Priority and Ranking	2-40
2.5.5	Interrupt Operation: Detailed Description	2-46
2.5.6	Interrupt Latency	2-59
2.5.7	External Interrupts	2-61
2.5.8	Peripheral Interrupt Enable Sequence	2-61
2.5.9	Summary of Interrupt Operation	2-62
2.6	CPU Interrupt Registers	2-64
2.6.1	External Interrupt Control Registers	2-67

3	System Functions	3-1
	<i>Describes '240 functions that are not specific to any peripheral.</i>	
3.1	Peripheral Interface	3-2
3.2	System Configuration Registers	3-4
3.2.1	System Control Register (SYSCR)	3-6
3.2.2	System Status Register (SYSSR)	3-7
3.2.3	System Interrupt Vector Register (SYSIVR)	3-9
3.3	Power-Down Modes	3-10
3.3.1	Clock Generation	3-10
3.3.2	Setting and Entering the Power-Down Modes	3-12
3.3.3	Exiting the Power-Down Modes	3-12
3.3.4	Low-Power Mode	3-14
3.3.5	After Exiting Power-Down	3-16
3.3.6	Summary of Power-Down Mode Operation	3-18
4	PLL Clock Module	4-1
	<i>Describes the architecture, functions, and programming of the PLL Clock module.</i>	
4.1	PLL Clock Module Overview	4-2
4.2	PLL Clock Operation	4-5
4.2.1	Pin Description	4-5
4.2.2	Oscillator Operation Modes	4-6
4.2.3	PLL Operation Modes	4-6
4.2.4	CPU Clock (CPUCLK) Frequency Selection	4-7
4.2.5	System Clock (SYSCLK) Frequency Selection	4-8
4.2.6	Watchdog Counter Clock (WDCLK)	4-9
4.2.7	PLL Startup	4-9
4.2.8	Low-Power Modes	4-10
4.3	PLL Clock Control Registers	4-14
4.3.1	Clock Control Register 0 (CKCR0)	4-14
4.3.2	Clock Control Register 1 (CKCR1)	4-16
5	Watchdog and Real-Time Interrupt Module	5-1
	<i>Describes the watchdog (WD) and real-time Interrupt (RTI) module. The WD provides interrupts at selected intervals (1 to 4096 interrupts per second), while the RTI is operable by polling or interrupts. Covers the architecture of both functions as well as the registers used to set up the functions.</i>	
5.1	Watchdog (WD) and Real-Time Interrupt (RTI) Overview	5-2
5.1.1	WD and RTI Components	5-2
5.1.2	Control Registers	5-4
5.2	Operation of Watchdog (WD) and Real-Time Interrupt (RTI) Timers	5-6
5.2.1	WD Timer	5-6
5.2.2	RTI timer	5-9

5.3	Watchdog (WD) and Real-Time Interrupt (RTI) Control Registers	5-11
5.3.1	Real-Time Interrupt Counter Register (RTICNTR)	5-12
5.3.2	WD Counter Register (WDCNTR)	5-13
5.3.3	WD Reset Key Register (WDKEY)	5-13
5.3.4	RTI Control Register (RTICR)	5-14
5.3.5	WD Timer Control Register (WDCR)	5-16
5.4	Watchdog (WD) and Real-Time Interrupt (RTI) Routines	5-18
6	Event Manager Module	6-1
	<i>Describes the event manager (EV) module. Includes descriptions of the general purpose timer, compare units, pulse-width modulation waveform circuits, capture units, and quadrature encoder pulse circuits.</i>	
6.1	Event Manager (EV) Module Overview	6-2
6.1.1	EV Functional Blocks	6-2
6.1.2	EV Pins	6-4
6.1.3	Power-Drive Protection	6-5
6.1.4	EV Registers	6-6
6.1.5	EV Interrupts	6-6
6.2	Event Manager (EV) Register Addresses	6-8
6.3	General-Purpose (GP) Timers	6-11
6.3.1	GP Timer Functional Blocks	6-11
6.3.2	GP Timer Inputs	6-12
6.3.3	GP Timer Outputs	6-13
6.3.4	Control of GP Timer Operation	6-13
6.3.5	GP Timer Control Register (GPTCON)	6-13
6.3.6	GP Timer Compare Registers	6-13
6.3.7	GP Timer Period Register	6-14
6.3.8	Double Buffering of GP Timer Compare and Period Registers	6-14
6.3.9	GP Timer Compare/PWM Output	6-15
6.3.10	GP Timer Counting Direction	6-15
6.3.11	GP Timer Clock	6-16
6.3.12	32-Bit Timer	6-16
6.3.13	QEP-Based Clock Input	6-17
6.3.14	GP Timer Synchronization	6-17
6.3.15	ADC Start by GP Timer Event	6-17
6.3.16	GP Timer in Emulation Suspend	6-18
6.3.17	GP Timer Interrupts	6-18
6.4	GP Timer Counting Operation	6-19
6.4.1	Stop/Hold Mode	6-19
6.4.2	Single Up Counting Mode	6-19
6.4.3	Continuous Up Counting Mode	6-22
6.4.4	Directional Up/Down Counting Mode of GP Timers 1 and 3	6-25
6.4.5	Directional Up/Down Counting Mode of GP Timer 2	6-26
6.4.6	Single Up/Down Counting Mode	6-28
6.4.7	Continuous Up/Down Counting Mode	6-31

- 6.5 GP Timer Compare Operation 6-34
 - 6.5.1 Compare/PWM Transition 6-34
 - 6.5.2 Asymmetric/Symmetric Waveform Generator 6-34
 - 6.5.3 Asymmetric Waveform Generation 6-35
 - 6.5.4 Symmetric Waveform Generation 6-36
 - 6.5.5 Output Logic 6-37
 - 6.5.6 Compare Output in Directional Up/Down Counting Mode 6-38
 - 6.5.7 Active/Inactive Time Calculation 6-39
- 6.6 GP Timer Control Registers (TxCON and GPTCON) 6-40
- 6.7 Generation of Compare and PWM Outputs Using GP Timers 6-45
 - 6.7.1 Generation of Compare Output 6-45
 - 6.7.2 Generation of PWM Output 6-45
 - 6.7.3 GP Timer Reset 6-46
- 6.8 Compare Units 6-47
 - 6.8.1 Simple Compare Units 6-47
 - 6.8.2 Full Compare Units 6-48
 - 6.8.3 Full Compare Inputs/Outputs 6-49
 - 6.8.4 Full Compare Operation Modes 6-49
 - 6.8.5 Compare Mode 6-50
 - 6.8.6 PWM Mode 6-50
 - 6.8.7 Register Setup for Full Compare Operation 6-50
 - 6.8.8 Compare Unit Registers 6-51
 - 6.8.9 Compare Unit Interrupts 6-58
 - 6.8.10 Compare Unit Reset 6-58
- 6.9 PWM Circuits Associated With Full Compare Units 6-59
 - 6.9.1 PWM Generation Capability 6-60
 - 6.9.2 Programmable Dead-Band Unit 6-61
 - 6.9.3 Inputs and Outputs of Dead-Band Unit 6-62
 - 6.9.4 Dead-Band Generation 6-62
 - 6.9.5 Other Important Features of Dead-Band Units 6-65
 - 6.9.6 Output Logic 6-67
- 6.10 PWM Waveform Generation With Compare Units and PWM Circuits 6-69
 - 6.10.1 PWM Signals 6-69
 - 6.10.2 PWM Signal Generation 6-69
 - 6.10.3 Dead Band 6-70
 - 6.10.4 Generation of PWM Outputs With Event Manager 6-70
 - 6.10.5 Asymmetric and Symmetric PWM Generation 6-70
 - 6.10.6 Register Setup for PWM Generation 6-71
 - 6.10.7 Asymmetric PWM Waveform Generation 6-72
 - 6.10.8 Symmetric PWM Waveform Generation 6-73
- 6.11 Space-Vector PWM 6-74
 - 6.11.1 3-Phase Power Inverter 6-74
 - 6.11.2 Switching Patterns of a Power Inverter and Basic Space Vectors 6-74
 - 6.11.3 Approximation of Motor Voltage with Basic Space Vectors 6-76

6.11.4	Space-Vector PWM Waveform Generation With EV	6-77
6.11.5	Space-Vector PWM Waveforms	6-78
6.11.6	Unused Full Compare Register	6-78
6.11.7	Space-Vector PWM Boundary Conditions	6-78
6.12	Capture Units	6-80
6.12.1	Features	6-81
6.12.2	Operation of Capture Units	6-81
6.12.3	Capture Unit Registers	6-82
6.12.4	Capture Unit FIFO Stacks (CAPnFIFO, n = 1, 2, 3, 4)	6-87
6.13	Quadrature Encoder Pulse (QEP) Circuit	6-91
6.13.1	QEP Pins	6-91
6.13.2	QEP Circuit Time Base	6-91
6.13.3	QEP Decoding	6-92
6.13.4	QEP Counting	6-93
6.13.5	Register Setup for the QEP Circuit	6-93
6.14	Event Manager (EV) Interrupts	6-95
6.14.1	Organization of TMS320C240 Interrupts	6-95
6.14.2	EV Interrupt Requests and Services	6-95
6.14.3	EV Interrupt Flag Registers	6-99
6.14.4	EV Interrupt Mask Registers	6-104
6.14.5	EV Interrupt Vector Registers	6-108
7	Dual 10-Bit Analog-to-Digital Converter (ADC) Module	7-1
	<i>Describes the Dual 10-Bit Analog-to-Digital Converter (ADC) module.</i>	
7.1	Dual 10-Bit ADC Overview	7-2
7.2	ADC Operation	7-4
7.2.1	ADC Module Pin Description	7-4
7.2.2	ADC Module Operational Modes	7-4
7.2.3	Analog Signal Sampling/Conversion	7-6
7.3	ADC Registers	7-7
7.3.1	ADC Control Register 1 (ADCTRL1)	7-7
7.3.2	ADC Control Register 2 (ADCTRL2)	7-10
7.3.3	ADC Digital Result Registers	7-13
8	Serial Communications Interface (SCI) Module	8-1
	<i>Describes the architecture, functions, and programming of the serial communications interface (SCI) module.</i>	
8.1	SCI Overview	8-2
8.1.1	SCI Physical Description	8-2
8.1.2	Architecture	8-5
8.1.3	SCI Control Registers	8-5
8.1.4	Multiprocessor and Asynchronous Communications Modes	8-7
8.2	SCI Programmable Data Format	8-8
8.3	SCI Multiprocessor Communication	8-9
8.3.1	Idle-Line Multiprocessor Mode	8-10
8.3.2	Address-Bit Multiprocessor Mode	8-12

8.4	SCI Communication Format	8-14
8.4.1	Receiver Signals in Communications Modes	8-15
8.4.2	Transmitter Signals in Communications Modes	8-16
8.5	SCI Port Interrupts	8-17
8.5.1	SCI Baud Rate Calculation	8-18
8.6	SCI Control Registers	8-19
8.6.1	SCI Communication Control Register (SCICCR)	8-20
8.6.2	SCI Control Register 1 (SCICTL1)	8-22
8.6.3	Baud-Select Registers (SCIHBAUD and SCILBAUD)	8-25
8.6.4	SCI Control Register 2 (SCICTL2)	8-26
8.6.5	Receiver Status Register (SCIRXST)	8-27
8.6.6	Receiver Data Buffer Registers	8-29
8.6.7	Transmit data buffer register (SCITXBUF)	8-30
8.6.8	Port Control Register 2 (SCIPC2)	8-31
8.6.9	Priority Control Register (SCIPRI)	8-33
8.7	SCI Initialization Example	8-34
9	Serial Peripheral Interface (SPI) Module	9-1
	<i>Describes the architecture, functions, and programming of the serial peripheral interface (SPI) module.</i>	
9.1	SPI Overview	9-2
9.1.1	SPI Physical Description	9-2
9.1.2	SPI Control Registers	9-4
9.2	SPI Operation	9-6
9.2.1	Introduction to Operation	9-6
9.2.2	SPI Module Slave and Master Operation Modes	9-7
9.2.3	SPI Interrupts	9-8
9.2.4	Data Format	9-10
9.2.5	Baud Rate and Clocking Schemes	9-11
9.2.6	Initialization Upon Reset	9-14
9.2.7	Data Transfer Example	9-15
9.3	SPI Control Registers	9-17
9.3.1	SPI Configuration Control Register (SPICCR)	9-18
9.3.2	SPI Operation Control Register (SPICTL)	9-20
9.3.3	SPI Status Register (SPISTS)	9-23
9.3.4	SPI Baud Rate Register (SPIBRR)	9-24
9.3.5	SPI Emulation Buffer Register (SPIEMU)	9-26
9.3.6	SPI Serial Input Buffer Register (SPIBUF)	9-27
9.3.7	SPI Serial Data Register (SPIDAT)	9-28
9.3.8	SPI Port Control Register 1 (SIPIC1)	9-29
9.3.9	SPI Port Control Register 2 (SIPIC2)	9-31
9.3.10	SPI Priority Control Register (SPIPRI)	9-33
9.4	SPI Operation-Mode Initialization Examples	9-34

10	Flash Memory Module	10-1
	<i>Describes how the flash EEPROM module is used and how to erase and program the flash array.</i>	
10.1	Flash EEPROM Overview	10-2
10.2	Fundamental Concepts	10-3
10.2.1	Erasing	10-5
10.2.2	Writing	10-6
10.3	Flash Registers	10-7
10.3.1	Flash Segment Control Register (SEG_CTR)	10-7
10.3.2	Flash Test Register (TST)	10-10
10.3.3	Write Address Register (WADRS)	10-10
10.3.4	Write Data Register (WDATA)	10-10
11	External Memory Interface	11-1
	<i>Describes the external memory interface, including interface to program memory, local data memory, and I/O space. Describes the wait-state generator.</i>	
11.1	External Interface to Program Memory	11-2
11.2	External Interface to Local Data Memory	11-5
11.3	Interface to I/O Space	11-8
11.4	Memory Interface Timing Diagrams	11-10
11.5	Wait-State Generator	11-12
11.5.1	Generating Wait States With the READY Signal	11-12
11.5.2	Generating Wait States With the Wait-State Generator	11-12
12	Digital I/O Ports	12-1
	<i>Describes the digital I/O ports module.</i>	
12.1	Digital I/O Ports Overview	12-2
12.2	Digital I/O and Shared Pin Functions	12-2
12.2.1	Description of Group1 Shared I/O Pins	12-2
12.2.2	Description of Group 2 Shared I/O Pins	12-5
12.3	Digital I/O Control Registers	12-6
A	Summary of Programmable Registers on the TMS320F/C240	A-1
	<i>Provides a summary of all programmable registers and shows the individual register configurations.</i>	
A.1	CPU Registers	A-6
A.2	Watchdog (WD) and Real-time Interrupt (RTI) Registers	A-9
A.3	PLL Clock Registers	A-11
A.4	Dual 10-Bit Analog to Digital Converter (ADC) Registers	A-12
A.5	Serial Peripheral Interface (SPI) Registers	A-14
A.6	Serial Communications Interface (SCI) Registers	A-17
A.7	External Interrupt Control Registers	A-20
A.8	Digital I/O Control Registers	A-21
A.9	General Purpose (GP) Timer Registers	A-23

A.10	Compare Unit Registers	A-28
A.11	Capture Unit Registers	A-32
A.12	Dead-Band Timer Control Register	A-35
A.13	Event Manager (EV) Interrupt Registers	A-36
A.14	Flash Control Mode Register—Including Flash Segment Control Register	A-39
A.15	Wait-State Generator Control Register	A-40
B	Glossary	B-1
	<i>Explains terms, abbreviations, and acronyms used throughout this book.</i>	
C	Summary of Updates in This Document	C-1
	<i>Provides a summary of the updates in this version of the document.</i>	

Figures

1-1	TMS320 Family	1-3
1-2	TMS320 Device Nomenclature	1-4
2-1	TMS320F/C240 Device Overview	2-3
2-2	TMS320F/C240 Pin Out Assignment	2-4
2-3	TMS320F/C240 Functional Block Diagram	2-14
2-4	TMS320F/C240 Memory Map	2-16
2-5	'240 Peripheral Memory Map	2-18
2-6	Shared Pin Configuration	2-19
2-7	I/O MUX Control Register A (OCRA) — Address 7090h	2-22
2-8	I/O MUX Control Register B (OCRB) — Address 7092h	2-23
2-9	I/O Port A Data and Direction Register (PADATDIR) — Address 7098h	2-24
2-10	I/O Port B Data and Direction Register (PBDATDIR) — Address 709Ah	2-25
2-11	I/O Port C Data and Direction Register (PCDATDIR) — Address 709Ch	2-26
2-12	Reset Signals	2-31
2-13	Maskable Interrupt Structure For CPU Interrupt Level 1	2-38
2-14	DSP Interrupt Structure	2-40
2-15	System-Module Interrupt Structure	2-41
2-16	Event Manager Interrupt Structure	2-42
2-17	Interrupt Operation Flow Chart	2-47
2-18	Interrupt Service Routine Flow Chart	2-49
2-19	Interrupt Flag Register (IFR) — Address 0006h	2-65
2-20	Interrupt Mask Register (IMR) — Address 0004h	2-67
2-21	External Interrupt Control Registers	2-68
2-22	NMI Control Register	2-69
2-23	XINT1 Control Register (7070h)	2-71
2-24	XINT2 Control Register (7078h)	2-72
2-25	XINT3 Control Register (707Ah)	2-74
3-1	System Configuration Registers	3-5
3-2	System Control Register (SYSCR) — Address 7018h	3-6
3-3	System Status Register (SYSSR) — Address 701Ah	3-7
3-4	System Interrupt Vector Register (SYSIVR) — Address 701Eh	3-9
3-5	Waking Up the Device from Power Down	3-17
4-1	PLL Clock Module Block Diagram	4-3
4-2	Clock Control Register 0 (CKCR0) — Address 702Bh	4-14
4-3	Clock Control Register 1 (CKCR1) — Address 702Dh	4-16
5-1	Watchdog (WD) and Real-Time Interrupt (RTI) Module Block Diagram	5-3

5-2	WD/RTI Module Control Registers	5-11
5-3	Real-Time Interrupt Counter Register (RTICNTR) — Address 7021h	5-12
5-4	WD Counter Register (WDCNTR) — Address 7023h	5-13
5-5	WD Reset Key Register (WDKEY) — Address 7025h	5-13
5-6	RTI Control Register (RTICR) — Address 7027h	5-14
5-7	WD Timer Control Register (WDCR) — Address 7029h	5-16
6-1	Event Manager (EV) Block Diagram	6-3
6-2	GP Timer Block Diagram (x = 1, 2, or 3)	6-12
6-3	GP Timer Single Up Counting Mode (TxPR = 4 – 1 = 3)	6-20
6-4	GP Timer Continuous Up Counting Mode (TxPR = 3 or 2)	6-23
6-5	Directional Up/Down Counting Mode of GP Timers 1 and 3 With Prescale Factor 1 and TxPR = 3	6-26
6-6	GP Timer Single Up/down Counting Mode (TxPR = 3)	6-29
6-7	GP Timer Continuous Up/Down Counting Mode (TxPR = 3 or 2)	6-32
6-8	GP Timer Compare/PWM Output in Up Counting Mode	6-35
6-9	GP Timer Compare/PWM Output in Up/down Counting Modes	6-37
6-10	GP Timer Control Register (TxCON; x = 1, 2, and 3) — Addresses 7404h, 7408h, and 740Ch	6-40
6-11	GP Timer Control Register (GPTCON) — Address 7400h	6-42
6-12	Simple Compare Unit Block Diagram (x = 1, 2, or 3; y = 7, 8, or 9)	6-48
6-13	Full Compare Unit Block Diagram (x = 1, 2, 3; y = 1, 3, 5)	6-49
6-14	Compare Control Register (COMCON) — Address 7411h	6-51
6-15	Full Compare Action Control Register (ACTR) — Address 7413h	6-55
6-16	Simple Compare Action Control Register (SACTR) — Address 7414h	6-57
6-17	PWM Circuits Block Diagram	6-59
6-18	Dead-Band Timer Control Register (DBTCON) — Address 7415h	6-61
6-19	Dead-Band Unit Block Diagram (x = 1, 2, or 3)	6-64
6-20	Output Logic Block Diagram (x = 1, 2, or 3; y = 1, 2, 3, 4, 5, or 6)	6-68
6-21	Asymmetric PWM Waveform Generation With Full Compare Unit and PWM Circuits (x = 1, 3, or 5)	6-72
6-22	Symmetric PWM Waveform Generation With Full Compare Units and PWM Circuits (x = 1, 3, or 5)	6-73
6-23	3-Phase Power Inverter Schematic Diagram	6-74
6-24	Basic Space Vectors and Switching Patterns	6-76
6-25	Symmetric Space-Vector PWM Waveforms	6-79
6-26	Capture Units Block Diagram	6-80
6-27	Capture Control Register (CAPCON) — Address 7420h	6-83
6-28	Capture FIFO Status Register (CAPFIFO) — Address 7422h	6-85
6-29	Quadrature Encoder Pulse (QEP) Circuit Block Diagram	6-91
6-30	Quadrature Encoded Pulses and Decoded Timer Clock and Direction	6-92
6-31	EV Interrupt Flag Register A (EVIFRA) — Address 742Fh	6-99
6-32	EV Interrupt Flag Register B (EVIFRB) — Address 7430h	6-101
6-33	EV Interrupt Flag Register C (EVIFRC) — Address 7431h	6-103
6-34	EV Interrupt Mask Register A (EVIMRA) — Address 742Ch	6-104
6-35	EV Interrupt Mask Register B — Address 742Dh	6-106

6-36	EV Interrupt Mask Register C — Address 742Eh	6-107
6-37	EV Interrupt Vector Register A (EVIVRA) — Address 7432h	6-108
6-38	EV Interrupt Vector Register B (EVIVRB) — Address 7433h	6-108
6-39	EV Interrupt Vector Register C (EVIVRC) — Address 7434h	6-109
7-1	ADC Module Block Diagram	7-3
7-2	ADC Control Register 1 (ADCTRL1) — Address 7032h	7-7
7-3	ADC Control Register 2 (ADCTRL2) — Address 7034h	7-10
7-4	ADC Data Registers FIFO1 (ADCFIFO1) — Address 7036h and FIFO2 (ADCFIFO2) — Address 7038h	7-13
8-1	SCI Block Diagram	8-4
8-2	Typical SCI Data Frame Formats	8-8
8-3	Idle-Line Multiprocessor Communication Format	8-10
8-4	Double-Buffered WUT and TXSHF	8-11
8-5	Address-Bit Multiprocessor Communication Format	8-13
8-6	SCI Asynchronous Communications Format	8-14
8-7	SCI RX Signals in Communication Modes	8-15
8-8	SCI TX Signals in Communications Modes	8-16
8-9	SCI Control Registers	8-19
8-10	SCI Communication Control Register (SCICCR) — Address 7050h	8-20
8-11	SCI Control Register 1 (SCICTL1) — Address 7051h	8-22
8-12	SCI Baud-Select MSbyte Register (SCIHBAUD) — Address 7052h	8-25
8-13	SCI Baud-Select LSbyte Register (SCILBAUD) — Address 7053h	8-25
8-14	SCI Control Register 2 (SCICTL2) — Address 7054h	8-26
8-15	SCI Receiver Status Register (SCIRXST) — Address 7055h	8-27
8-16	SCIRXST Bit Associations	8-29
8-17	SCI Emulation Data Buffer Register (SCIRXEMU) — Address 7056h	8-30
8-18	SCI Receiver Data Buffer Register (SCIRXBUF) — Address 7057h	8-30
8-19	SCI Transmit Data Buffer Register (SCITXBUF) — Address 7059h	8-30
8-20	SCI Port Control Register 2 (SCIPC2) — Address 705Eh	8-31
8-21	SCI Priority Control Register (SCIPRI) — Address 705Fh	8-33
9-1	4-Pin SPI Module Block Diagram (Slave Mode)	9-3
9-2	SPI Master/Slave Connection (4-Pin Option)	9-7
9-3	SPICLK Signal Options	9-13
9-4	SPI: SPICLK-SYSCLOCK Characteristic when (BRR + 1) is Odd, BRR > 3, and CLOCK POLARITY = 1	9-14
9-5	Signals Connecting to Master Processor	9-15
9-6	Five Bits per Character	9-16
9-7	SPI Control Registers	9-17
9-8	SPI Configuration Control Register (SPICCR) — Address 7040h	9-18
9-9	SPI Operation Control Register (SPICTL) — Address 7041h	9-20
9-10	SPICLK Signal Options	9-22
9-11	SPI Status Register (SPISTS) — Address 7042h	9-23
9-12	SPI Baud Rate Register (SPIBRR) — Address 7044h	9-24
9-13	SPI Emulation Buffer Register (SPIEMU) — Address 7046h	9-26

9-14	SPI Serial Input Buffer Register (SPIBUF) — Address 7047h	9-27
9-15	SPI Serial Data Register (SPIDAT) — Address 7049h	9-28
9-16	SPI Port Control Register 1 (SPIPC1) — Address 704Dh	9-29
9-17	SPI Port Control Register 2 (SPIPC2) — Address 704Eh	9-31
9-18	SPI Priority Control Register (SPIPRI) — Address 704Fh	9-33
10-1	Flash Bit Programming	10-3
10-2	Segment Control Register (SEG_CTR)	10-8
11-1	Interface to External Program Memory	11-3
11-2	Interface to External Data Memory	11-7
11-3	I/O Port Interface	11-9
11-4	Memory Interface Read Waveforms	11-10
11-5	Memory Interface Write Waveforms	11-11
11-6	Wait-State Generator Control Register (WSGR)	11-12
12-1	Shared Pin Configuration	12-3
12-2	I/O MUX Control Register A (OCRA) — Address 7090h	12-6
12-3	I/O MUX Control Register B (OCRB) — Address 7092h	12-7
12-4	I/O Port A Data and Direction Register (PADATDIR) — Address 7098h	12-8
12-5	I/O Port B Data and Direction Register (PBDATDIR) — Address 709Ah	12-9
12-6	I/O Port C Data and Direction Register (PCDATDIR) — Address 709Ch	12-10
A-1	Status Register 0 (ST0) — Internal CPU Register	A-6
A-2	Status Register 1 (ST1) — Internal CPU Register	A-6
A-3	Interrupt Mask Register (IMR) — Address 0004h	A-7
A-4	Global Memory Allocation Register (GREG) — Address 0005h	A-7
A-5	Interrupt Flag Register (IFR) — Address 0006h	A-7
A-6	System Control Register (SYSCR) — Address 7018h	A-7
A-7	System Status Register (SYSSR) — Address 701Ah	A-8
A-8	System Interrupt Vector Register (SYSIVR) — Address 701Eh	A-8
A-9	Real-Time Interrupt Counter Register (RTICNTR) — Address 7021h	A-9
A-10	Watchdog Counter Register (WDCNTR) — Address 7023h	A-9
A-11	Watchdog Reset Key Register (WDKEY) — Address 7025h	A-10
A-12	Real-Time Interrupt Control Register (RTICR) — Address 7027h	A-10
A-13	Watchdog Timer Control Register (WDCR) — Address 7029h	A-10
A-14	Clock Control Register 0 (CKCR0) — Address 702Bh	A-11
A-15	Clock Control Register 1 (CKCR1) — Address 702Dh	A-11
A-16	ADC Control Register 1 (ADCTRL1) — Address 7032h	A-12
A-17	ADC Control Register 2 (ADCTRL2) — Address 7034h	A-12
A-18	ADC Data Register FIFO1 (ADC_FIFO1) — Address 7036h	A-13
A-19	ADC Data Register FIFO2 (ADC_FIFO2) — Address 7038h	A-13
A-20	SPI Configuration Control Register (SPICCR) — Address 7040h	A-14
A-21	SPI Operation Control Register (SPICTL) — Address 7041h	A-14
A-22	SPI Status Register (SPISTS) — Address 7042h	A-14
A-23	SPI Baud Rate Register (SPIBRR) — Address 7044h	A-14
A-24	SPI Emulation Buffer Register (SPIEMU) — Address 7046h	A-15
A-25	SPI Serial Input Buffer Register (SPIBUF) — Address 7047h	A-15

A-26	SPI Serial Data Register (SPIDAT) — Address 7049h	A-15
A-27	SPI Port Control Register 1 (SPIPC1) — Address 704Dh	A-15
A-28	SPI Port Control Register 2 (SPIPC2) — Address 704Eh	A-16
A-29	SPI Priority Control Register (SPIPRI) — Address 704Fh	A-16
A-30	SCI Communication Control Register (SCICCR) — Address 7050h	A-17
A-31	SCI Control Register 1 (SCICTL1) — Address 7051h	A-17
A-32	SCI Baud-Select Register, High Bits (SCIHBAUD) — Address 7052h	A-17
A-33	SCI Baud-Select Register, Low Bits (SCILBAUD) — Address 7053h	A-17
A-34	SCI Control Register 2 (SCICTL2) — Address 7054h	A-18
A-35	SCI Receiver Status Register (SCIRXST) — Address 7055h	A-18
A-36	SCI Emulation Data Buffer Register (SCIRXEMU) — Address 7056h	A-18
A-37	SCI Receiver Data Buffer Register (SCIRXBUF) — Address 7057h	A-18
A-38	SCI Transmit Data Buffer Register (SCITXBUF) — Address 7059h	A-19
A-39	SCI Port Control Register 2 (SCIPC2) — Address 705Eh	A-19
A-40	SCI Priority Control Register (SCIPRI) — Address 705Fh	A-19
A-41	External Interrupt 1 Control Register (XINT1CR) — Address 7070h	A-20
A-42	Nonmaskable Interrupt Control Register (NMICR) — Address 7072h	A-20
A-43	External Interrupt 2 Control Register (XINT2CR) — Address 7078h	A-20
A-44	External Interrupt 3 Control Register (XINT3CR) — Address 707Ah	A-20
A-45	I/O MUX Control Register A (OCRA) — Address 7090h	A-21
A-46	I/O MUX Control Register B (OCRB) — Address 7092h	A-21
A-47	I/O Port A Data and Direction Register (PADATDIR) — Address 7098h	A-22
A-48	I/O Port B Data and Direction Register (PBDATDIR) — Address 709Ah	A-22
A-49	I/O Port C Data and Direction Register (PCDATDIR) — Address 709Ch	A-22
A-50	GP Timer Control Register (GPTCON) — Address 7400h	A-23
A-51	GP Timer 1 Counter Register (T1CNT) — Address 7401h	A-23
A-52	GP Timer 1 Compare Register (T1CMPR) — Address 7402h	A-24
A-53	GP Timer 1 Period Register (T1PR) — Address 7403h	A-24
A-54	GP Timer 1 Control Register (T1CON) — Address 7404h	A-24
A-55	GP Timer 2 Counter Register (T2CNT) — Address 7405h	A-25
A-56	GP Timer 2 Compare Register (T2CMPR) — Address 7406h	A-25
A-57	GP Timer 2 Period Register (T2PR) — Address 7407h	A-25
A-58	GP Timer 2 Control Register (T2CON) — Address 7408h	A-26
A-59	GP Timer 3 Counter Register (T3CNT) — Address 7409h	A-26
A-60	GP Timer 3 Compare Register (T3CMPR) — Address 740Ah	A-26
A-61	GP Timer 3 Period Register (T3PR) — Address 740Bh	A-27
A-62	GP Timer 3 Control Register (T3CON) — Address 740Ch	A-27
A-63	Compare Control Register (COMCON) — Address 7411h	A-28
A-64	Full-Compare Action Control Register (ACTR) — Address 7413h	A-28
A-65	Full-Compare Unit Compare Register 1 (CMPR1) — Address 7417h	A-29
A-66	Full-Compare Unit Compare Register 2 (CMPR2) — Address 7418h	A-29
A-67	Full-Compare Unit Compare Register 3 (CMPR3) — Address 7419h	A-29
A-68	Simple-Compare Action Control Register (SACTR) — Address 7414h	A-30
A-69	Simple-Compare Unit Compare Register 1 (SCMPR1) — Address 741Ah	A-30

A-70	Simple-Compare Unit Compare Register 2 (SCMPR2) — Address 741Bh	A-30
A-71	Simple-Compare Unit Compare Register 3 (SCMPR3) — Address 741Ch	A-31
A-72	Capture Control Register (CAPCON) — Address 7420h	A-32
A-73	Capture FIFO Status Register (CAPFIFO) — Address 7422h	A-32
A-74	Capture 1 FIFO Stack Register (CAP1FIFO) — Address 7423h	A-33
A-75	Capture 2 FIFO Stack Register (CAP2FIFO) — Address 7424h	A-33
A-76	Capture 3 FIFO Stack Register (CAP3FIFO) — Address 7425h	A-33
A-77	Capture 4 FIFO Stack Register (CAP4FIFO) — Address 7426h	A-34
A-78	Dead-Band Timer Control Register (DBTCN) — Address 7415h	A-35
A-79	EV Interrupt Mask Register A (EVIMRA) — Address 742Ch	A-36
A-80	EV Interrupt Mask Register B (EVIMRB) — Address 742Dh	A-36
A-81	EV Interrupt Mask Register C (EVIMRC) — Address 742Eh	A-36
A-82	EV Interrupt Flag Register A (EVIFRA) — Address 742Fh	A-37
A-83	EV Interrupt Flag Register B (EVIFRB) — Address 7430h	A-37
A-84	EV Interrupt Flag Register C (EVIFRC) — Address 7431h	A-37
A-85	EV Interrupt Vector Register A (EVIVRA) — Address 7432h	A-38
A-86	EV Interrupt Vector Register B (EVIVRB) — Address 7433h	A-38
A-87	EV Interrupt Vector Register C (EVIVRC) — Address 7434h	A-38
A-88	Flash Control Mode Register (FCMR) — I/O Space Address FF0Fh	A-39
A-89	Segment Control Register (SEG_CTR) — Program Space Address 0h	A-39
A-90	Wait-State Generator Control Register (WSGR) — I/O Space Address FFFFh	A-40

Tables

2-1	Characteristics of the TMS320F/C240 DSP Controllers	2-2
2-2	TMS320F/C240 Pin Functions	2-5
2-3	TMS320F/C240 Shared Pin Configuration	2-20
2-4	Group 2 Shared Pins	2-21
2-5	Addresses of Digital I/O Control Registers	2-21
2-6	I/O MUX Control Register A (OCRA) Configuration	2-22
2-7	I/O MUX Control Register B (OCRB) Configuration	2-23
2-8	'240 DSP Core Interrupt Locations and Priorities	2-29
2-9	Interrupt Priorities at the Level of the DSP Core	2-36
2-10	Interrupt Lines Controlled by the System Module and Event Manager	2-37
2-11	'240 Interrupt Locations and Priorities	2-44
2-12	'240 Maskable Interrupt Vector Table	2-50
2-13	Example of Method 1 ISR	2-52
2-14	Example of Method 2 ISR	2-54
2-15	Example of Method 3 ISR	2-56
2-16	Implementation of an ISR for NMI	2-57
3-1	CPU Cycles to Complete Reads From and Writes to the Peripheral Bus	3-3
3-2	Power-Down Modes	3-12
3-3	Setting the Power-Down Mode With the PLLPM Bits	3-12
3-4	Low Power Modes	3-14
3-5	Power-Down Modes and Their Terminations	3-15
3-6	External Interrupt Types and Functions	3-19
4-1	Addresses of PLL Clock Module Control Registers	4-4
4-2	Oscillator Operation Mode Selection	4-6
4-3	Selectable CPU Clock Frequencies in MHz	4-8
4-4	PLL Prescale Selection Options	4-8
4-5	Watchdog Counter Clock Frequencies	4-9
4-6	Low-Power Modes	4-11
4-7	CLKMD(1:0) Bits vs. Clock Mode	4-14
4-8	CKINF(3:0) Bits vs. Clock-In Frequency (Internal CPU Clock)	4-16
4-9	PLLFB(2:0) Bits vs. PLL Multiplication Ratio	4-17
5-1	Addresses of WD/RTI Module Registers	5-5
5-2	Typical WDKEY Register Power -up Sequence	5-7
5-3	Real-Time Interrupt Selections	5-15
5-4	WD Overflow (Timeout) Selections	5-17
6-1	EV Pins	6-5

6-2	Addresses of GP Timer Registers	6-8
6-3	Addresses of Full and Simple Compare Unit Registers	6-9
6-4	Addresses of Capture Unit and Quadrature Encoder Pulse Decoding Circuit Registers	6-9
6-5	Addresses of EV Interrupt Registers	6-10
6-6	GP Timer Compare/PWM Output in Single Up and Continuous Up Counting Modes	6-38
6-7	GP Timer Compare/PWM Output in Single Up/Down and Continuous Up/Down Counting Modes	6-38
6-8	Dead-Band Generation Examples	6-63
6-9	Switching Patterns of a 3-Phase Power Inverter	6-75
6-10	Event Manager Interrupts	6-97
7-1	Sample Clock Frequencies and Appropriate Prescaler Values	7-6
7-2	Addresses of ADC Registers	7-7
8-1	Addresses of SCI Registers	8-6
8-2	Programming the Data Format Using SCICCR	8-8
8-3	Asynchronous Baud Register Values for Common SCI Bit Rates	8-18
8-4	SCI CHAR2 — 0 Bit Values and Character Lengths	8-21
8-5	SW RESET-Affected Flags	8-23
9-1	Addresses of SPI Control Registers	9-5
9-2	SPI Clocking Scheme Selection Guide	9-13
9-3	Character Length Control Bit Values	9-19
10-1	Addresses of Flash EEPROM Module Registers	10-7
11-1	Key Signals for External Interfacing to Program Memory	11-2
11-2	Key Signals for External Interfacing to Local Data Memory	11-5
12-1	TMS320C240 Shared Pin Configuration	12-4
12-2	Group 2 Shared Pins	12-5
12-3	Addresses of Digital I/O Control Registers	12-6
12-4	I/O MUX Control Register A (OCRA) Configuration	12-7
12-5	I/O MUX Control Register B (OCRB) Configuration	12-8
A-1	Addresses of TMS320F/C240 Registers	A-2

Examples

5-1	Watchdog (WD) and Real-Time Interrupt (RTI) Enable Routine	5-18
5-2	Watchdog (WD) and Real-Time Interrupt (RTI) Disable Routine	5-19
6-1	Initialization Routine for Single Up Counting Mode	6-21
6-2	Initialization Routine for Continuous Up Counting Mode	6-24
6-3	Initialization Routine for Directional Up/down Counting Mode Using An External Clock	6-27
6-4	Initialization Routine for Single Up/Down Counting Mode	6-30
6-5	Initialization Routine for the Continuous Up/Down Counting Mode	6-33
6-6	Example of COMCON Configuration for Full Compare Units in PWM Mode	6-54
6-7	Initialization Routine for Dead-Band Generation	6-66
6-8	Initialization Routine for Capture Units	6-88
6-9	Register Setup for a QEP Circuit	6-94
7-1	ADC Initialization Example	7-14
8-1	Asynchronous Communication Routine	8-34
9-1	Transmission of Bit from SPIBUF	9-10
9-2	Maximum Baud-Rate Calculation	9-12
9-3	TMS320x240 SPI Slave Mode Code	9-34
9-4	TMS320x240 SPI Master Mode Code	9-40
11-1	External I/O Port Access	11-8
11-2	I/O-Mapped Register Access	11-8

Notes, Cautions, and Warnings

Sharing device pins	6-2
Initialize period registers, compare register transparency	6-15
Synchronization of the GP Timers	6-42
Shoot-Through Fault	6-62
Clearing Interrupt Flags in EVIFx	6-98
Address-Bit Format for Transfers of 11 Bytes or Less	8-13
Do Not Change Configuration when SW RESET bit = 1	8-22
Register Bit Naming Protocol	9-6
Proper SPI Initialization Using the SPI SW RESET Bit	9-14
Reading the SPIBUF	9-27
Segment Protection	10-8

Introduction

The TMS320C24x ('C24x) series is a member of the TMS320 family of digital signal processors (DSPs). The 'C24x series is designed to meet a wide range of digital motor control (DMC) and embedded control applications.

This reference guide discusses the peripherals available on the TMS320F240/C240 DSP controllers. For a description of the 'C2xx CPU core and instruction set, refer to *TMS320F/C24x DSP Controllers, CPU and Instruction Set Reference Guide* (literature number SPRU160).

This chapter provides an overview of the current TMS320 family, describes the background and benefits of the 'C24x DSP controller products, and introduces the 'F/C240 device.

Topic	Page
1.1 TMS320 Family Overview	1-2
1.2 TMS320C24x Series of DSP Controllers	1-5
1.3 TMS320F/C240 Overview	1-7

1.1 TMS320 Family Overview

The TMS320 family consists of fixed-point, floating-point, multiprocessor digital signal processors (DSPs), and fixed-point DSP controllers. TMS320 DSPs have an architecture designed specifically for real-time signal processing. The 'F/C240 is a member of the 'C2000 DSP platform, and is optimized for control applications. The 'C24x series of DSP controllers combines this real-time processing capability with controller peripherals to create an ideal solution for control system applications. The following characteristics make the TMS320 family the right choice for a wide range of processing applications:

- Very flexible instruction set
- Inherent operational flexibility
- High-speed performance
- Innovative parallel architecture
- Cost effectiveness

In 1982, Texas Instruments introduced the TMS32010, the first fixed-point DSP in the TMS320 family. Before the end of the year, *Electronic Products* magazine awarded the TMS32010 the title "Product of the Year". Today, the TMS320 family consists of these generations (Figure 1–1): 'C1x, 'C2x, 'C2xx, 'C5x, 'C54x, and 'C6x fixed-point DSPs; 'C3x and 'C4x floating-point DSPs; and 'C8x multiprocessor DSPs. The 'C24x is part of the 'C2xx family of DSPs designed using the 2xLP DSP core.

Devices within a generation of the TMS320 family have the same CPU structure but different on-chip memory and peripheral configurations. Spin-off devices use new combinations of on-chip memory and peripherals to satisfy a wide range of needs in the worldwide electronics market. By integrating memory and peripherals onto a single chip, TMS320 devices reduce system costs and save circuit board space.

Figure 1–1. TMS320 Family

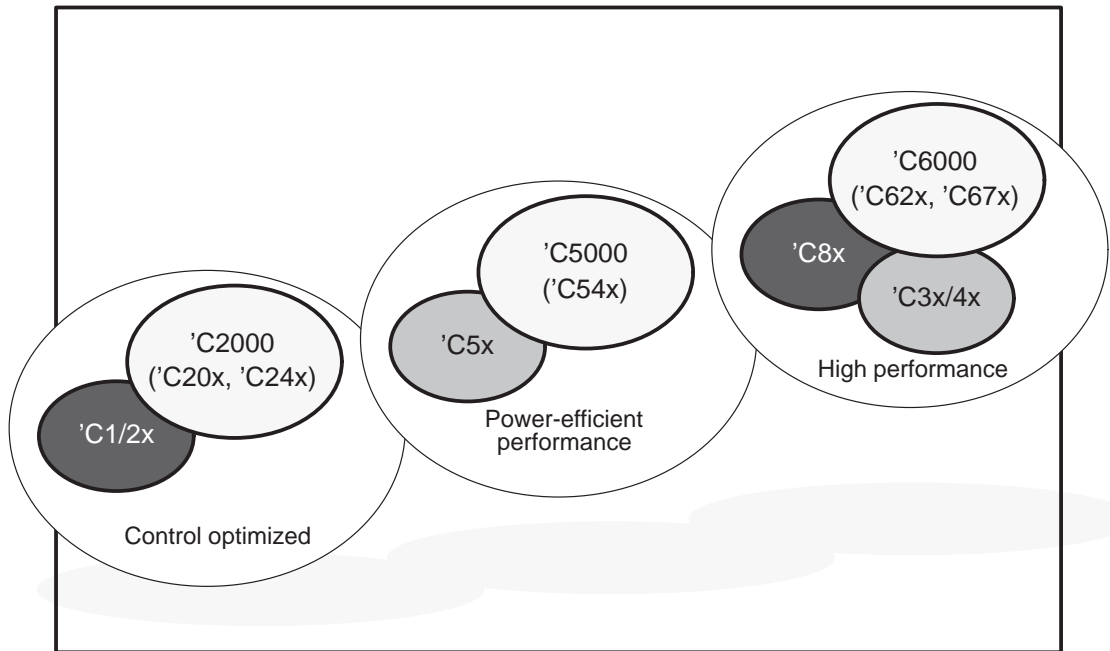
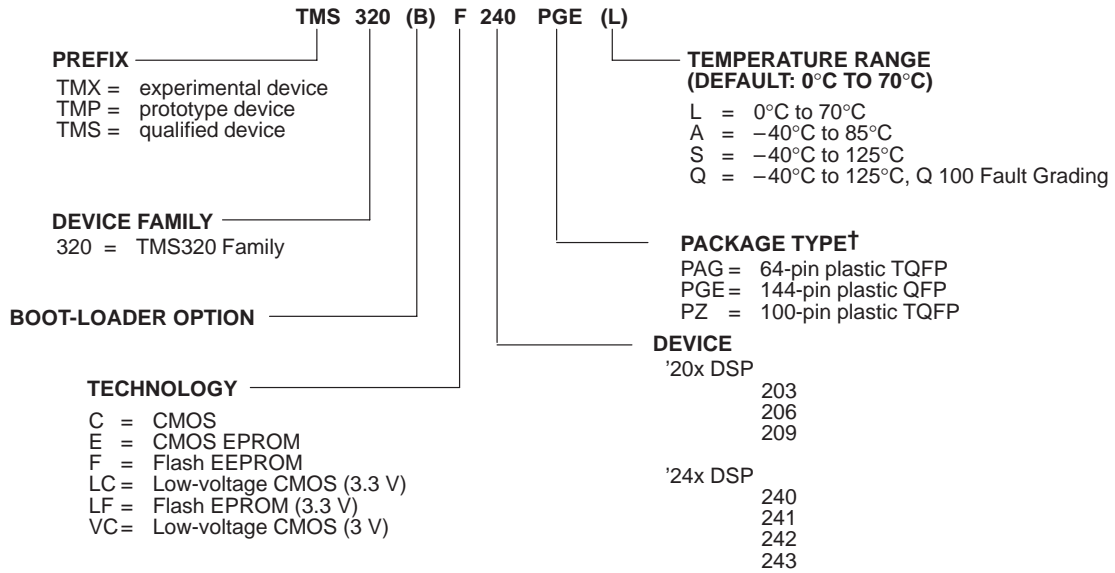

Figure 1–2. TMS320 Device Nomenclature



† PLCC = Plastic J-Leaded Chip Carrier
 QFP = Quad Flatpack
 TQFP = Thin Quad Flatpack

1.2 TMS320C24x Series of DSP Controllers

Designers have recognized the opportunity to redesign existing DMC systems to use advanced algorithms that yield better performance and reduce system component count. DSPs enable:

- Design of robust controllers for a new generation of inexpensive motors, such as AC induction, DC permanent magnet, and switched-reluctance motors
- Full variable-speed control of brushless motor types that have lower manufacturing cost and higher reliability
- Energy savings through variable-speed control, saving up to 25% of the energy used by fixed-speed controllers
- Increased fuel economy, improved performance, and elimination of hydraulic fluid in automotive electronic power steering (EPS) systems
- Reduced manufacturing and maintenance costs by eliminating hydraulic fluids in automotive electronic braking systems
- More efficient and quieter operation due to less generation of torque ripple, resulting in less loss of power, lower vibration, and longer life
- Elimination or reduction of memory lookup tables through real-time polynomial calculation, thereby reducing system cost
- Use of advanced algorithms that can reduce the number of sensors required in a system
- Control of power switching inverters, along with control algorithm processing
- Single-processor control of multimotor systems

The 'C24x DSP controllers are designed to meet the needs of control-based applications. By integrating the high performance of a DSP core and the on-chip peripherals of a microcontroller into a single-chip solution, the 'C24x series yields a device that is an affordable alternative to traditional microcontroller units (MCUs) and expensive multichip designs. At 20 million instructions per second (MIPS), the 'C24x DSP controllers offer significant performance over traditional 16-bit microcontrollers and microprocessors.

The 16-bit, fixed-point DSP core of the 'C24x devices provides analog designers a digital solution that does not sacrifice the precision and performance of their systems. In fact, system performance can be enhanced through the use of advanced control algorithms for techniques such as adaptive control, Kalman filtering, and state control. The 'C24x DSP controllers offer reliability and programmability. Analog control systems, on the other hand, are hard-wired solutions and can experience performance degradation due to aging, component tolerance, and drift.

The high-speed central processing unit (CPU) allows the digital designer to process algorithms in real time rather than approximate results with look-up tables. The instruction set of these DSP controllers, which incorporates both signal processing instructions and general-purpose control functions, coupled with the extensive development support available for the 'C24x devices, reduces development time and provides the same ease of use as traditional 8- and 16-bit microcontrollers. The instruction set also allows you to retain your software investment when moving from other general-purpose TMS320 fixed-point DSPs. It is source- and object-code compatible with the other members of the 'C2xx generation, source code compatible with the 'C2x generation, and upwardly source code compatible with the 'C5x generation of DSPs from Texas Instruments.

The 'C24x architecture is also well-suited for processing control signals. It uses a 16-bit word length along with 32-bit registers for storing intermediate results, and has two hardware shifters available to scale numbers independently of the CPU. This combination minimizes quantization and truncation errors, and increases processing power for additional functions. Such functions might include a notch filter that could cancel mechanical resonances in a system or an estimation technique that could eliminate state sensors in a system.

The 'C24x DSP controllers take advantage of an existing set of peripheral functions that allow Texas Instruments to quickly configure various series members for different price/performance points or for application optimization. This library of both digital and mixed-signal peripherals includes:

- Timers
- Serial communications ports (SCI, SPI)
- Analog-to-digital converters (ADC)
- Event manager
- System protection, such as low-voltage detection and watchdog timers

The DSP controller peripheral library is continually growing and changing to suit the needs of tomorrow's embedded control marketplace.

1.3 TMS320F/C240 Overview

The TMS320F/C240 is the first standard device introduced in the '24x series of DSP controllers. It sets the standard for a single-chip digital motor controller. The '240 can execute 20 MIPS. Almost all instructions are executed in a single cycle of 50 ns. This high performance allows real-time execution of very complex control algorithms, such as adaptive control and Kalman filters. Very high sampling rates can also be used to minimize loop delays.

The '240 has the architectural features necessary for high-speed signal processing and digital control functions, and it has the peripherals needed to provide a single-chip solution for motor control applications. The '240 is manufactured using submicron CMOS technology, achieving a low power dissipation rating. Also included are several power-down modes for further power savings.

Some applications that benefit from the advanced processing power of the '240 include:

- Industrial motor drives
- Power inverters and controllers
- Automotive systems, such as electronic power steering, antilock brakes, and climate control
- Appliance and HVAC blower/compressor motor controls
- Printers, copiers, and other office products
- Tape drives, magnetic optical drives, and other mass storage products
- Robotics and CNC milling machines

To function as a system manager, a DSP must have robust on-chip I/O and other peripherals. The event manager of the '240 is unlike any other available on a DSP. This application-optimized peripheral unit, coupled with the high-performance DSP core, enables the use of advanced control techniques for high-precision and high-efficiency full variable-speed control of all motor types. Included in the event manager are special pulse-width modulation (PWM) generation functions, such as a programmable dead-band function and a space vector PWM state machine for 3-phase motors that provides state-of-the-art maximum efficiency in the switching of power transistors. Three independent up/down timers, each with its own compare register, support the generation of asymmetric (noncentered) as well as symmetric (centered) PWM waveforms. Two of the four capture inputs are direct connections for quadrature encoder pulse signals from an optical encoder.

Here is a summary of '240 features:

- ❑ TMS320C2xx core CPU:
 - 32-bit central arithmetic logic unit (CALU)
 - 32-bit accumulator
 - 16-bit × 16-bit parallel multiplier with a 32-bit product capability
 - Three scaling shifters
 - Eight 16-bit auxiliary registers with a dedicated arithmetic unit for indirect addressing of data memory
- ❑ Memory:
 - 544 words × 16 bits of on-chip data/program dual-access RAM
 - 16K words × 16 bits of on-chip program ROM or flash EEPROM
 - 224K words × 16 bits of maximum addressable memory space (64K words of program space, 64K words of data space, 64K words of I/O space, and 32K words of global space)
 - External memory interface module with a software wait-state generator, a 16-bit address bus, and a 16-bit data bus
 - Support of hardware wait-states
- ❑ Program control:
 - 4-level pipeline operation
 - 8-level hardware stack
 - Six external interrupts: power-drive protection interrupt, reset, NMI, and three maskable interrupts
- ❑ Instruction set:
 - Source code compatibility with 'C2x, 'C2xx, and 'C5x fixed-point generations of the TMS320 family
 - Single-instruction repeat operation
 - Single-cycle multiply/accumulate instructions
 - Memory block move instructions for program/data management
 - Indexed-addressing capability
 - Bit-reversed indexed-addressing capability for radix-2 fast Fourier transforms (FFTs)
- ❑ Power:
 - Static CMOS technology
 - Four power-down modes to reduce power consumption

- ❑ Emulation: IEEE Standard 1149.1 test access port interface to on-chip scan-based emulation logic
- ❑ Speed: 50-ns (20 MIPS) instruction cycle time, with most instructions single cycle
- ❑ Event manager:
 - 12 compare/pulse-width modulation (PWM) channels (9 independent)
 - Three 16-bit general-purpose timers with six modes, including continuous up counting and continuous up/down counting
 - Three 16-bit full compare units with dead band capability
 - Three 16-bit simple compare units
 - Four capture units, two of which have quadrature-encoder-pulse-interface capability
- ❑ Dual 10-bit analog-to-digital converter (ADC)
- ❑ 28 individually programmable, multiplexed I/O pins
- ❑ Phase-locked loop (PLL) -based clock module
- ❑ Watchdog (WD) timer module with real-time interrupt (RTI)
- ❑ Serial communication interface (SCI)
- ❑ Serial peripheral interface (SPI)
- ❑ Development tools available:
 - TI ANSI C compiler, assembler/linker, and C-source debugger
 - Full range of emulation products: self-emulation (XDS510™)
 - Evaluation module (EVM) with JTAG emulation
 - Third-party digital motor control and fuzzy-logic development support

TMS320F/C240 DSP Controller

This chapter contains a general description of the '240 DSP Controller and provides a pin-out diagram and memory maps.

Topic	Page
2.1 TMS320F/C240 DSP Controller Overview	2-2
2.2 Memory Map	2-15
2.3 Peripheral Memory Map	2-17
2.4 Digital I/O and Shared Pin Functions	2-19
2.5 Interrupts	2-27
2.6 CPU Interrupt Registers	2-64

2.1 TMS320F/C240 DSP Controller Overview

The TMS320C240 and TMS320F240 devices are the first members of a new family of DSP controllers based on the TMS320C2xx generation of 16-bit fixed-point digital signal processors (DSPs). Unless otherwise noted, the term '240 refers to both the TMS320C240 and the TMS320F240.

The only difference between these two devices is the type of program memory (see Table 2–1): the 'C240 contains 16K words of ROM and the 'F240 contains 16K words of flash EEPROM. This new family is optimized for digital motor and motion control applications. The DSP controllers combine the enhanced TMS320 architectural design of the 'C2xx core CPU for low-cost, high-performance processing capabilities and several advanced peripherals optimized for motor/motion control applications. These peripherals include the event manager (EV) module, which provides general-purpose timers and compare registers to generate up to 12 PWM outputs; and a dual, 10-bit analog-to-digital converter (ADC), which can perform two simultaneous conversions within 10 μ s.

Figure 2–1 shows an overview of the '240 signals, Figure 2–2 provides a pin out diagram, and Table 2–2 provides a list of the 'C240 and 'F240 Pin Functions.

Table 2–1. Characteristics of the TMS320F/C240 DSP Controllers

'F/C240 Devices	On-chip Memory (Words)				Power Supply (V)	Cycle Time (ns)	Package Type Pin Count
	RAM		ROM	Flash EEPROM			
	Data	Data/Program	PROG	PROG			
'C240	288	256	16K	–	5	50	PQ 132–P
'F240	288	256	–	16K	5	50	PQ 132–P

Figure 2–1. TMS320F/C240 Device Overview

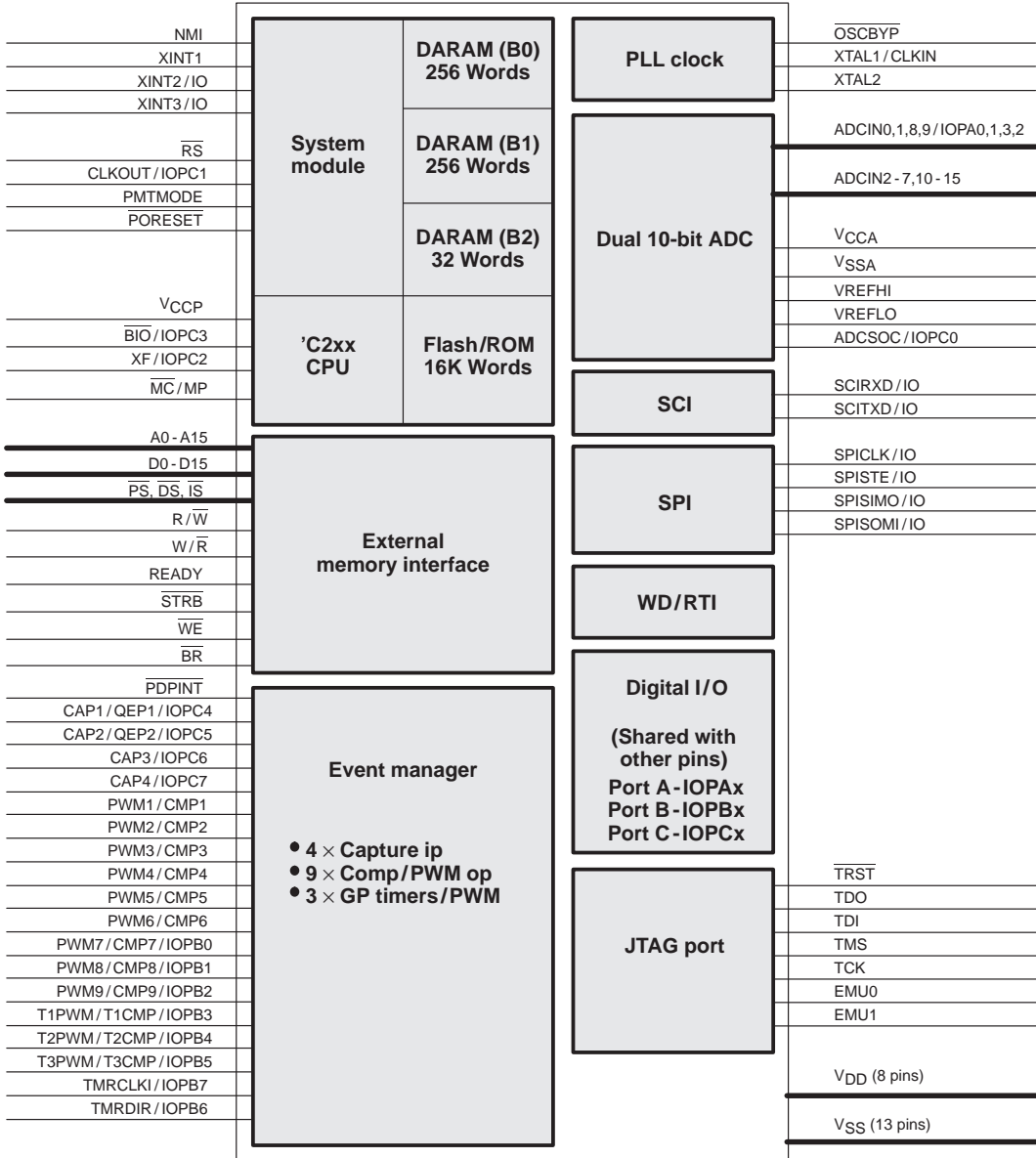
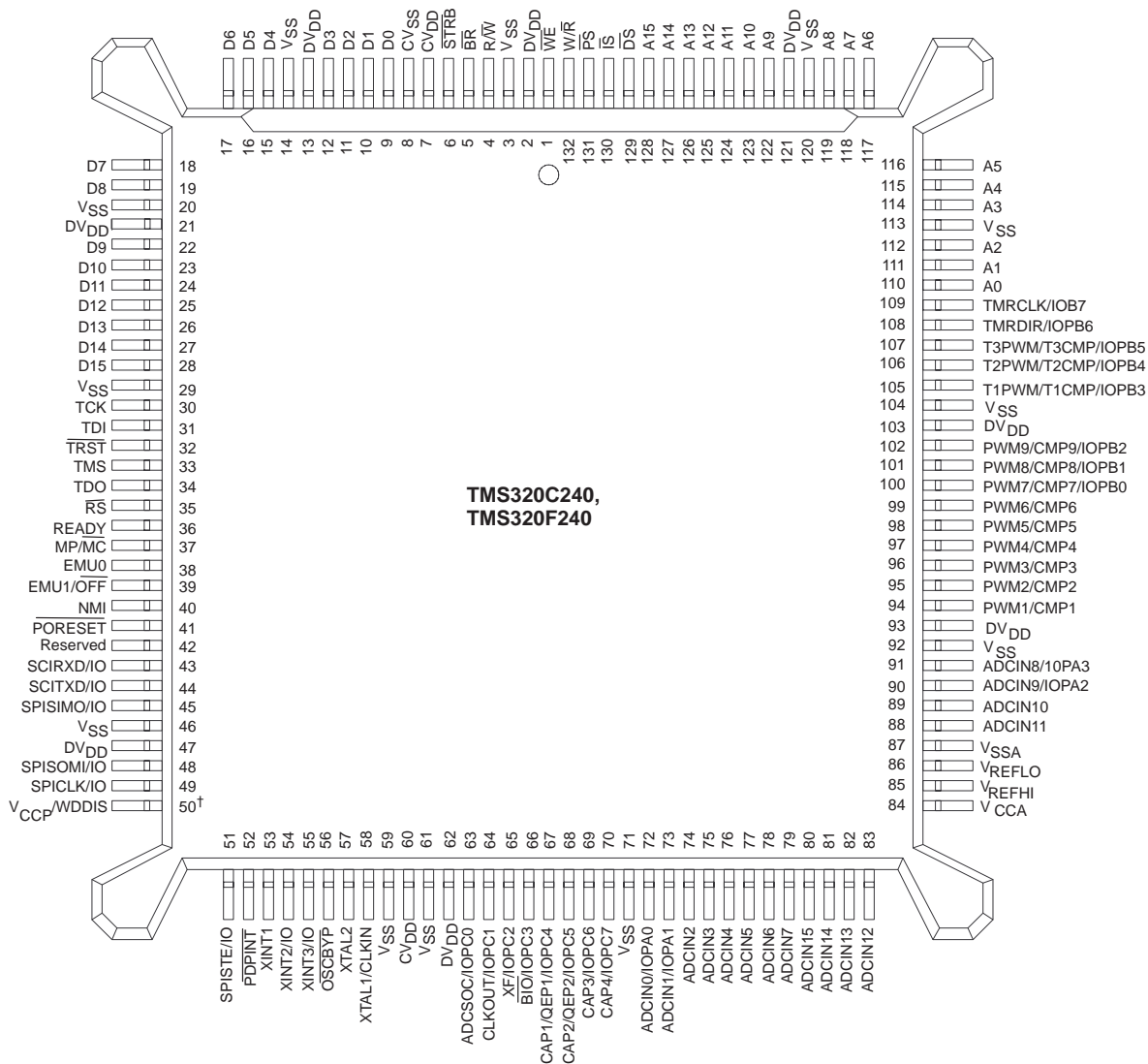

Figure 2–2. TMS320F/C240 Pin Out Assignment



† For TMS320C240 devices, this pin has only the WDDIS function.

Table 2–2. TMS320F/C240 Pin Functions

Pin			
Name	No.	Type†	Description
A0 (LSB)	110		
A1	111		
A2	112		
A3	114		
A4	115		
A5	116		
A6	117		
A7	118	O/Z	Parallel address bus A0 (LSB) through A15 (MSB). Multiplexed to address external data/program memory or I/O. Placed in high-impedance state when EMU1/ $\overline{\text{OFF}}$ is active low. They hold their previous states in power-down modes.
A8	119		
A9	122		
A10	123		
A11	124		
A12	125		
A13	126		
A14	127		
A15 (MSB)	128		
<hr/>			
D0 (LSB)	9		
D1	10		
D2	11		
D3	12		
D4	15		
D5	16		
D6	17		
D7	18	I/O/Z	Parallel data bus D0 (LSB) through D15 (MSB). Multiplexed to transfer data between the TMS320F/C240 and external data/program memory and I/O space (devices). Placed in the high-impedance state when not outputting, when in power-down mode, when reset ($\overline{\text{RS}}$) is asserted, or when EMU1/ $\overline{\text{OFF}}$ is active low.
D8	19		
D9	22		
D10	23		
D11	24		
D12	25		
D13	26		
D14	27		
D15 (MSB)	28		

† I = input, O = output, Z = high impedance

Table 2–2. TMS320F/C240 Pin Functions (Continued)

Interface Control Signals			
\overline{DS} \overline{PS} \overline{IS}	129 131 130	O/Z	Data, program, and I/O space select signals. Always high unless low level asserted for communication to a particular external space. Placed in the high-impedance state during reset, power down, and when EMU1/ \overline{OFF} is active low.
READY	36	I	Data ready input. Indicates that an external device is prepared for the bus transaction to be completed. If the device is not ready (READY is low), the processor waits one cycle and checks READY again.
R/\overline{W}	4	O/Z	Read/write signal. Indicates transfer direction during communication to an external device. Normally in read mode (high), unless low level is asserted for performing a write operation. Placed in the high-impedance state during reset, power down, and when EMU1/ \overline{OFF} is active low.
\overline{STRB}	6	O/Z	Strobe signal. Always high unless asserted low to indicate an external bus cycle. Placed in the high-impedance state during reset, power down, and when EMU1/ \overline{OFF} is active low.
\overline{WE}	1	O/Z	Write enable. The falling edge of \overline{WE} indicates that the device is driving the external data bus(D15-D0). Data can be latched by an external device on the rising edge of \overline{WE} . \overline{WE} is active on all external program, data, and I/O writes. \overline{WE} goes in the high-impedance state following reset and when EMU1/ \overline{OFF} is active low.
W/\overline{R}	132	O/Z	Write/read signal. This signal is an inverted form of R/\overline{W} and can connect directly to the output enable of external devices. W/\overline{R} is placed in active high state following reset and when EMU1/ \overline{OFF} is active low.
\overline{BR}	5	O/Z	Bus-request signal. \overline{BR} is asserted during access of external global data memory space. \overline{BR} can be used to extend the data memory address space by up to 32K words. \overline{BR} goes in the high-impedance state during reset, power-down mode, and when EMU1/ \overline{OFF} is active low.
$V_{CCP}/WDDIS^\ddagger$	50	I	Flash programming voltage supply pin. If $V_{CCP} = 5\text{ V}$, then WRITE/ERASE can be made to the entire on-chip flash memory block, i.e., for programming the flash. If $V_{CCP} = 0\text{ V}$, the flash array cannot be programmed. WDDIS also functions as a hardware watchdog disable. The watchdog timer is disabled when $V_{CCP}/WDDIS = 5\text{ V}$ and bit 6 in WDCR is set to 1.

† I = input, O = output, Z = high impedance

‡ For TMS320C240 devices, this pin is WDDIS.

Table 2–2. TMS320F/C240 Pin Functions (Continued)

ADC Inputs (Unshared)			
ADCIN2	74	I	
ADCIN3	75	I	
ADCIN4	76	I	Analog inputs to the first ADC
ADCIN5	77	I	
ADCIN6	78	I	
ADCIN7	79	I	
ADCIN10	89	I	
ADCIN11	88	I	
ADCIN12	83	I	Analog inputs to the second ADC
ADCIN13	82	I	
ADCIN14	81	I	
ADCIN15	80	I	
Bit I/O and Shared Functions Pins			
ADCIN0/IOPA0	72	I/O	Bidirectional digital I/O Analog input to the first ADC ADCIN0/IOPA0 is configured as a digital input by all device resets.
ADCIN1/IOPA1	73	I/O	Bidirectional digital I/O Analog input to the first ADC ADCIN1/IOPA1 is configured as a digital input by all device resets.
ADCIN9/IOPA2	90	I/O	Bidirectional digital I/O Analog input to the second ADC ADCIN9/IOPA2 is configured as a digital input by all device resets.
ADCIN8/IOPA3	91	I/O/Z	Bidirectional digital I/O Analog input to the second ADC ADCIN8/IOPA3 is configured as a digital input by all device resets.
PWM7/ CMP7/IOPB0	100	I/O/Z	Bidirectional digital I/O. Simple compare/PWM 1 output pin. The state of the pin is determined by the simple compare/PWM and the simple action control register (SACTR). It goes to the high-impedance state when unmasked $\overline{\text{PDPINT}}$ goes active low. PWM7/CMP7/IOPB0 is configured as a digital input device by all device resets.

† I = input, O = output, Z = high impedance

Table 2–2. TMS320F/C240 Pin Functions (Continued)

Bit I/O and Shared Functions Pins (continued)			
PWM8/CMP8/ IOPB1	101	I/O/Z	Bidirectional digital I/O. Simple compare/PWM 2 output pin. The state of the pin is determined by the simple compare/PWM and the SACTR. It goes to the high-impedance state when unmasked $\overline{\text{PDPINT}}$ goes active low. PWM8/CMP8/IOPB1 is configured as a digital input device by all device resets.
PWM9/CMP9/ IOPB2	102	I/O/Z	Bidirectional digital I/O. Simple compare/PWM 3 output pin. The state of the pin is determined by the simple compare/PWM and SACTR. It goes to the high-impedance state when unmasked $\overline{\text{PDPINT}}$ goes active low. PWM9/CMP9/IOPB2 is configured as a digital input device by all device resets.
T1PWM/T1CMP/ IOPB3	105	I/O/Z	Bidirectional digital I/O. Timer 1 compare output. It goes to the high-impedance state when unmasked $\overline{\text{PDPINT}}$ goes active low. This pin is configured as a digital input by all device resets.
T2PWM/T2CMP/ IOPB4	106	I/O/Z	Bidirectional digital I/O. Timer 2 compare output. It goes to the high-impedance state when unmasked $\overline{\text{PDPINT}}$ goes active low. This pin is configured as a digital input by all device resets.
T3PWM/T3CMP/ IOPB5	107	I/O/Z	Bidirectional digital I/O. Timer 3 compare output. It goes to the high-impedance state when unmasked $\overline{\text{PDPINT}}$ goes active low. This pin is configured as a digital input by all device resets.
TMRDIR/IOPB6	108	I/O	Bidirectional digital I/O. Direction signal for the timers. Up-counting direction if this pin is low, down-counting direction if this pin is high. This pin is configured as a digital input by all device resets.
TMRCLK/IOPB7	109	I/O	Bidirectional digital I/O External clock input for general-purpose timers This pin is configured as a digital input by all device resets.
ADCSOC/IOPC0	63	I/O	Bidirectional digital I/O External start of conversion input for ADC This pin is configured as a digital input by all device resets.
CAP1/QEP1/IOPC4	67	I/O	Bidirectional digital I/O Capture 1 or QEP 1 input This pin is configured as a digital input by all device resets.
CAP2/QEP2/IOPC5	68	I/O	Bidirectional digital I/O Capture 2 or QEP 2 input This pin is configured as a digital input by all device resets.

† I = input, O = output, Z = high impedance

Table 2–2. TMS320F/C240 Pin Functions (Continued)

Bit I/O and Shared Functions Pins (continued)			
CAP3/IOPC6	69	I/O	Bidirectional digital I/O Capture 3 input This pin is configured as a digital input by all device resets.
CAP4/IOPC7	70	I/O	Bidirectional digital I/O Capture 4 input This pin is configured as a digital input by all device resets.
XF/IOPC2	65	I/O	Bidirectional digital I/O. External flag output (latched software-programmable signal). XF is used for signaling other processors in multiprocessing configurations or as a general-purpose output pin. This pin is configured as an external flag output by all device resets.
$\overline{\text{BIO}}$ /IOPC3	66	I/O	Bidirectional digital I/O. Branch control input. $\overline{\text{BIO}}$ is polled by BIOZ instruction. If $\overline{\text{BIO}}$ is low, the CPU executes a branch. If $\overline{\text{BIO}}$ is not used, it should be pulled high. This pin is configured as a branch control input by all device resets.
CLKOUT/IOPC1	64	I/O	Bidirectional digital I/O. Clock output pin. Clock output is selected by CLKSRC bits in SYSCR register. This pin is configured as a DSP clock output by a power-on reset.
Serial Communication and Bit I/O Pins			
SCITXD/IO	44	I/O	SCI asynchronous serial port transmit data, or general-purpose bidirectional I/O. This pin is configured as a digital input by all device resets.
SCIRXD/IO	43	I/O	SCI asynchronous serial port receive data, or general-purpose bidirectional I/O. This pin is configured as a digital input by all device resets.
SPISIMO/IO	45	I/O	SPI slave in, master out, or general-purpose bidirectional I/O. This pin is configured as a digital input by all device resets.
SPISOMI/IO	48	I/O	SPI slave out, master in, or general-purpose bidirectional I/O. This pin is configured as a digital input by all device resets.
SPICLK/IO	49	I/O	SPI clock, or general-purpose bidirectional I/O. This pin is configured as a digital input by all device resets.
SPISTE/IO	51	I/O	SPI slave transmit enable (optional), or general-purpose bidirectional I/O. This pin is configured as a digital input by all device resets.

† I = input, O = output, Z = high impedance

Table 2–2. TMS320F/C240 Pin Functions (Continued)

Compare Signals			
PWM1/CMP1	94		Compare units compare or PWM outputs. The state of these pins is determined by the compare/PWM and the full-action control register (ACTR). CMP1–CMP6 go to the high-impedance state when unmasked $\overline{\text{PDPINT}}$ goes active low, and when reset ($\overline{\text{RS}}$) is asserted.
PWM2/CMP2	95		
PWM3/CMP3	96	O/Z	
PWM4/CMP4	97		
PWM5/CMP5	98		
PWM6/CMP6	99		
Interrupt and Miscellaneous Signals			
$\overline{\text{RS}}$	35	I/O	Reset input. Causes the TMS320F/C240 to terminate execution and sets PC = 0. When $\overline{\text{RS}}$ is brought to a high level, execution begins at location 0h of program memory. $\overline{\text{RS}}$ affects (or sets to zero) various registers and status bits.
$\text{MP}/\overline{\text{MC}}$	37	I	$\text{MP}/\overline{\text{MC}}$ (microprocessor/microcomputer) select. If low, internal program memory is selected. If high, external program memory is selected.
NMI	40	I	Non-maskable interrupt. When this pin is activated, device is interrupted regardless of the state of the INTM bit of status register 0. NMI has programmable polarity.
$\overline{\text{PORESET}}$	41	I	Power-on reset input. $\overline{\text{PORESET}}$ causes the TMS320F/C240 to terminate execution and sets PC = 0. When $\overline{\text{PORESET}}$ is brought to a high level, execution begins at location 0h of program memory. $\overline{\text{PORESET}}$ affects (or sets to zero) the same registers and status bits as $\overline{\text{RS}}$. In addition, $\overline{\text{PORESET}}$ initializes the PLL control registers.
XINT1	53	I	External user interrupt number 1.
XINT2/I/O	54	I/O	External user interrupt number 2. General-purpose bidirectional I/O. This pin is configured as a digital input by all device resets.
XINT3/I/O	55	I/O	External user interrupt number 3. General-purpose bidirectional I/O. This pin is configured as a digital input by all device resets.
$\overline{\text{PDPINT}}$	52	I	Maskable power-drive protection interrupt. If $\overline{\text{PDPINT}}$ is unmasked and it goes to active low, the timer compare outputs immediately go to the high-impedance state.

† I = input, O = output, Z = high impedance

Table 2–2. TMS320F/C240 Pin Functions (Continued)

Clock Signals			
XTAL2	57	O	PLL oscillator output pin. XTAL2 is tied to one side of a reference crystal when the device is in PLL mode (CLKMD[1:0] = 1x, CKCR0.7:6). This pin can be left unconnected in oscillator bypass mode ($\overline{\text{OSCBYP}} \leq V_{\text{IL}}$). This pin goes in the high-impedance state when EMU1/ $\overline{\text{OFF}}$ is active low.
XTAL1/CLKIN	58	I/Z	PLL oscillator input pin. XTAL1/CLKIN is tied to one side of a reference crystal in PLL mode (CLKMD[1:0] = 1x, CKCR0.7:6), or is connected to an external clock source in oscillator bypass mode ($\overline{\text{OSCBYP}} \leq V_{\text{IL}}$).
$\overline{\text{OSCBYP}}$	56	I	Bypass oscillator if low.
Supply Signals			
CV _{SS}	8	I	Digital core logic ground reference
V _{SS}	3	I	Digital logic ground reference
	14		
	20		
	29		
	46		
	59		
	61		
	71		
	92		
	104		
113			
120			
V _{SSA}	87	I	Analog ground reference
DV _{DD}	2	I	Digital I/O logic supply voltage
	13		
	21		
	47		
	62		
	93		
	103		
121			
CV _{DD}	7 60	I	Digital core logic supply voltage
V _{CCA}	84	I	Analog supply voltage
V _{refHi}	85	I	ADC analog voltage reference high
V _{refLo}	86	I	ADC analog voltage reference low

† I = input, O = output, Z = high impedance

Table 2–2. TMS320F/C240 Pin Functions (Continued)

			Test Signals
TCK	30	I	IEEE standard test clock. This is normally a free-running clock signal with a 50% duty cycle. The changes on test-access port (TAP) input signals (TMS and TDI) are clocked into the TAP controller, instruction register, or selected test data register of the 'C2xx core on the rising edge of TCK. Changes at the TAP output signal (TDO) occur on the falling edge of TCK.
TDI	31	I	IEEE standard test data input (TDI). TDI is clocked into the selected register (instruction or data) on a rising edge of TCK.
TDO	34	O/Z	IEEE standard test data output (TDO). The contents of the selected register (instruction or data) is shifted out of TDO on the falling edge of TCK. TDO is in the high-impedance state when $\overline{\text{OFF}}$ is active low.
TMS	33	I	IEEE standard test mode select. This serial control input is clocked into the TAP controller on the rising edge of TCK.
$\overline{\text{TRST}}$	32	I	IEEE standard test reset. $\overline{\text{TRST}}$, when active low, gives the scan system control of the operations of the device. If this signal is not connected or driven low, the device operates in its functional mode, and the test reset signals are ignored.
EMU0	38	I/O/Z	Emulator pin 0. When $\overline{\text{TRST}}$ is driven low, this pin must be high for activation of the $\overline{\text{OFF}}$ condition (see pin 39). When $\overline{\text{TRST}}$ is driven high, this pin is used as an interrupt to or from the emulator system and is defined as input/output through the scan.
EMU1/ $\overline{\text{OFF}}$	39	I/O/Z	Emulator pin 1/disable all outputs. When $\overline{\text{TRST}}$ is driven high, this pin is used as an interrupt to or from the emulator system and is defined as input/output through JTAG scan. When $\overline{\text{TRST}}$ is driven low, this pin is configured as $\overline{\text{OFF}}$. The EMU1/ $\overline{\text{OFF}}$ signal, when active low, puts all output drivers in the high-impedance state. Note that $\overline{\text{OFF}}$ is used exclusively for testing and emulation purposes (not for multiprocessing applications). Thus, for $\overline{\text{OFF}}$ condition, the following conditions apply: $\overline{\text{TRST}}$ = low, EMU0 = high, EMU1/ $\overline{\text{OFF}}$ = low.
Reserved	42	I	Reserved for test. This pin has an internal pulldown and must be left unconnected for the 'F240. On the 'C240, this pin is a no connect.

† I = input, O = output, Z = high impedance

2.1.1 Architectural Overview

The functional block diagram (Figure 2–3) provides a high level description of each component in the '240 DSP controller device. The '240 devices are composed of three main functional units: a 'C2xx DSP core, internal memory, and peripherals. In addition to these three functional units, there are several system-level features of the '240 that are distributed. These system features include the memory map, device reset, interrupts, digital input/output (I/O), clock generation, and low-power operation.

Figure 2–3. TMS320F/C240 Functional Block Diagram

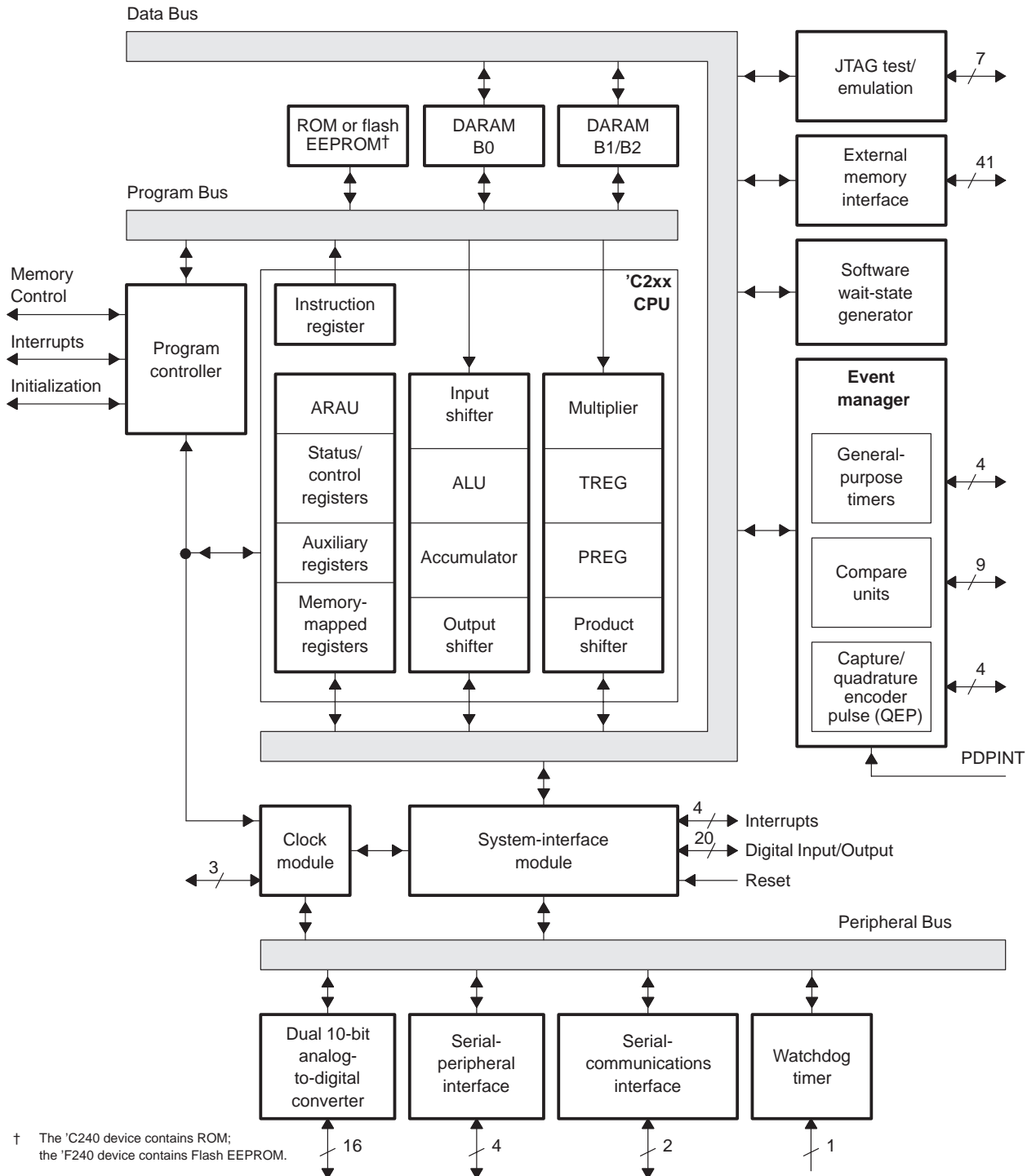

† The 'C240 device contains ROM; the 'F240 device contains Flash EEPROM.

2.2 Memory Map

The TMS320F/C240 implements three separate address spaces for program memory, data memory, and I/O. Each space accommodates a total of 64K 16-bit words. Within the 64K words of data space, the 256 to 32K words at the top of the address range can be defined as external global memory, in increments of powers of two, as specified by the contents of the global memory allocation register (GREG). Access to global memory is arbitrated using the global memory bus request ($\overline{\text{BR}}$) signal.

On the '240, the first 96 data memory locations (0–5Fh) are either allocated for memory-mapped registers or reserved. This memory-mapped register space contains various control and status registers including those for the CPU.

All '240 on-chip peripherals are mapped into data memory space starting at 7000h. Access to these registers is made by CPU instructions addressing their data memory locations. Figure 2–4 shows a memory map for the 'F/C240.

Figure 2–4. TMS320F/C240 Memory Map

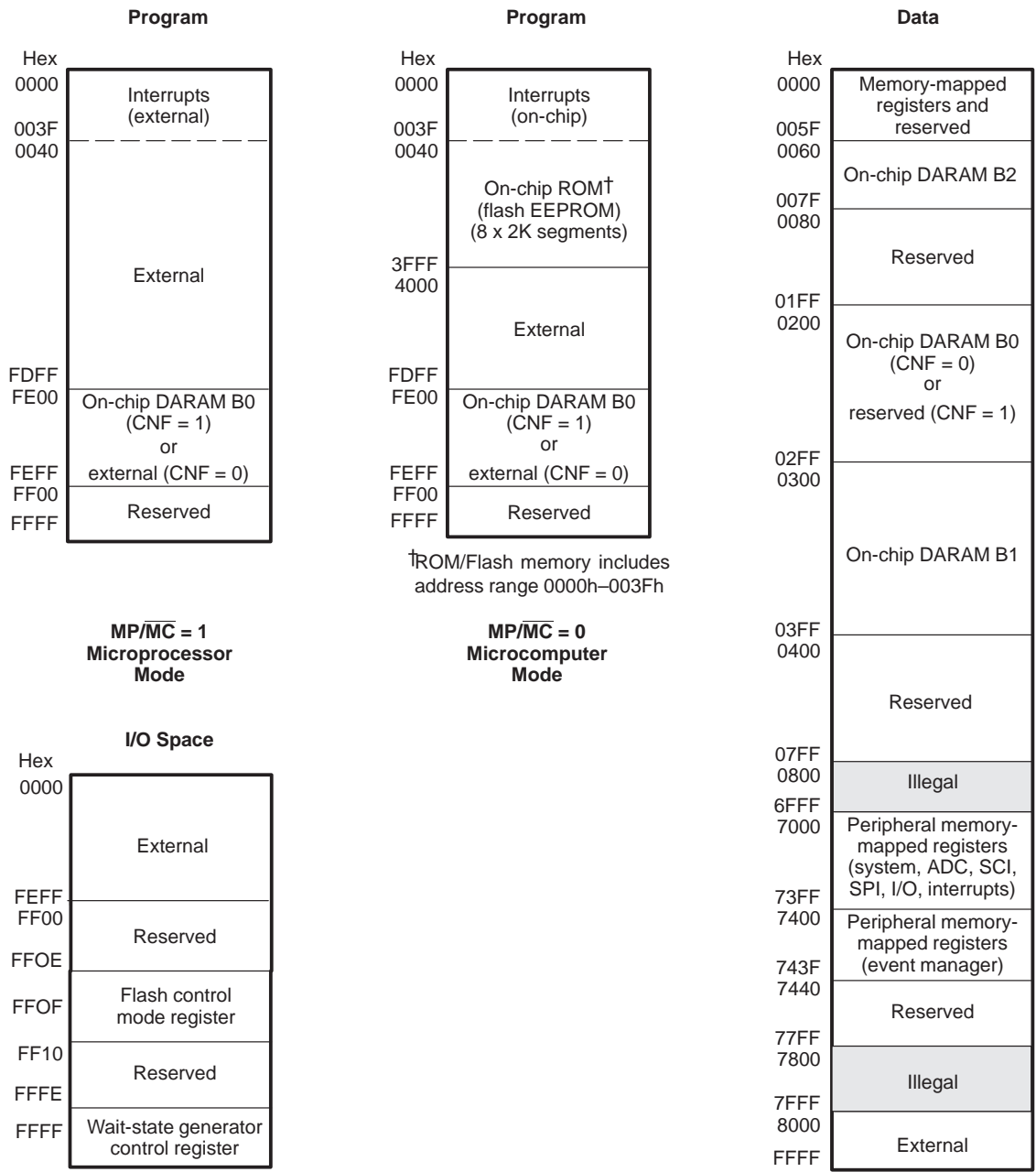

†ROM/Flash memory includes address range 0000h–003Fh

2.3 Peripheral Memory Map

The '240 system and peripheral control register frame contains all the data, status, and control bits to operate the system and peripheral modules on the '240 device.

Figure 2–5 shows the peripheral memory map for the '240.

Figure 2–5. '240 Peripheral Memory Map

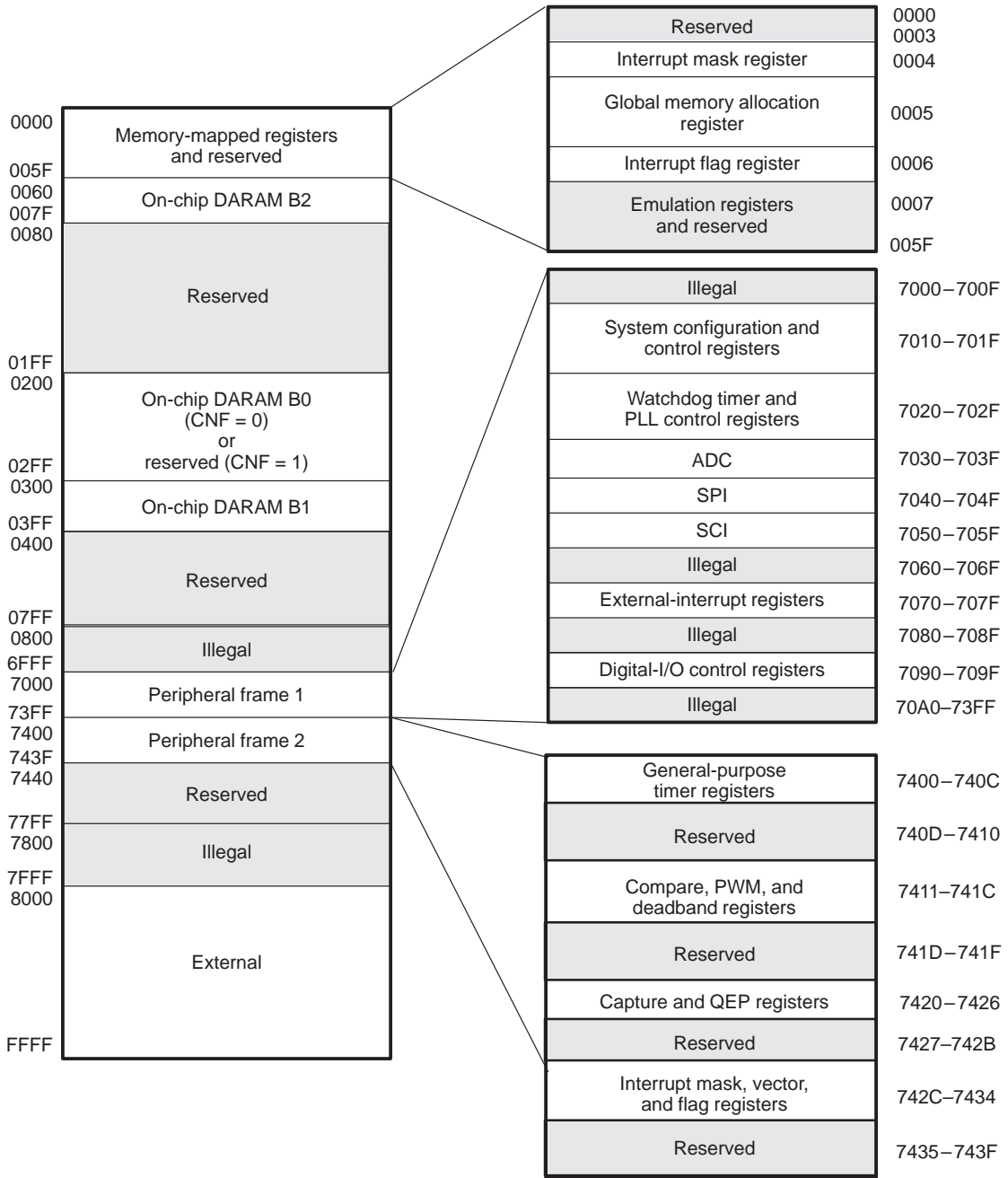

2.4 Digital I/O and Shared Pin Functions

The '240 has a total of 28 pins shared between primary functions and I/Os. These pins are divided into two groups:

- Group1** – Primary functions shared with I/Os belonging to dedicated I/O ports, Port A, Port B, and Port C.
- Group2** – Primary functions belonging to peripheral modules which also have an in-built I/O feature as a secondary function, for example SCI, SPI, external interrupts, and PLL clock module.

2.4.1 Description of Group1 Shared I/O pins

The control structure for Group1 type shared I/O pins is shown in Figure 2–6. The only exception to this configuration is the CLKOUT/IOPC1 pin, which is described later in this section. In Figure 2–6, each pin has three bits which define its operation:

- MUX control bit – this bit selects between the primary function (1) and I/O function (0) of the pin.
- I/O direction bit – if the I/O function is selected for the pin (MUX control bit is set to 0), this bit determines whether the pin is an input (0) or output (1).
- I/O data bit – if the I/O function is selected for the pin (MUX control bit is set to 0) and the direction selected is an input, data is read from this bit; if the direction selected is an output, data is written to this bit.

The MUX control bit, I/O direction bit, and I/O data bit are in the I/O control registers described in subsection 2.4.3 on page 2-21.

Figure 2–6. Shared Pin Configuration

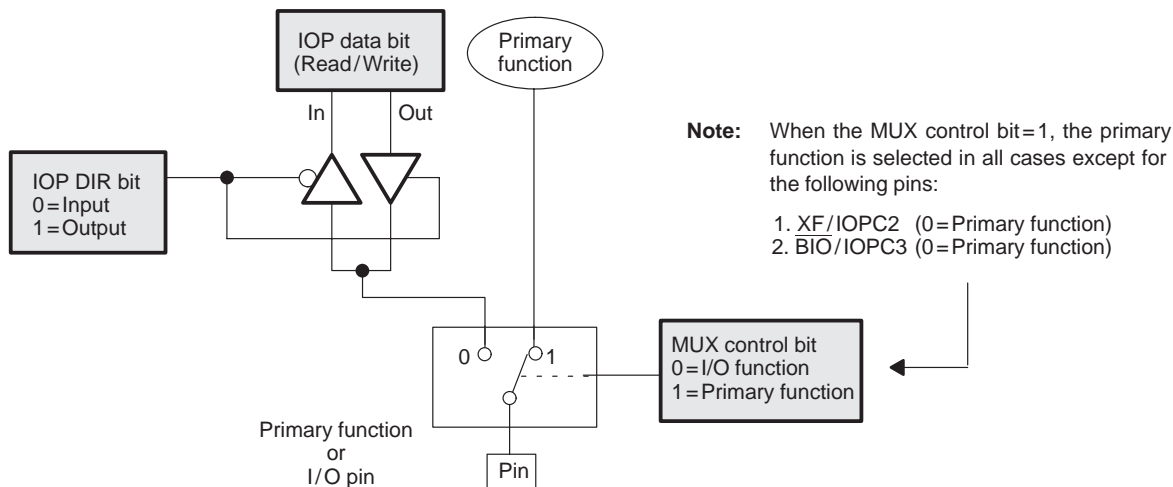

A summary of Group1 pin configurations and associated bits is shown in Table 2–3.

Table 2–3. TMS320F/C240 Shared Pin Configuration

Pin #	Mux Control Register (name.bit #)	Pin function selected		IO Port Data & Direction†		
		(CRx.n = 1)	(CRx.n = 0)	Register	Data bit #	Dir bit #
72	OCRA.0	ADCIN0	IOPA0	PADATDIR	0	8
73	OCRA.1	ADCIN1	IOPA1	PADATDIR	1	9
90	OCRA.2	ADCIN9	IOPA2	PADATDIR	2	10
91	OCRA.3	ADCIN8	IOPA3	PADATDIR	3	11
100	OCRA.8	PWM7/CMP7	IOPB0	PBDATDIR	0	8
101	OCRA.9	PWM8/CMP8	IOPB1	PBDATDIR	1	9
102	OCRA.10	PWM9/CMP9	IOPB2	PBDATDIR	2	10
105	OCRA.11	T1PWM/T1CMP	IOPB3	PBDATDIR	3	11
106	OCRA.12	T2PWM/T2CMP	IOPB4	PBDATDIR	4	12
107	OCRA.13	T3PWM/T3CMP	IOPB5	PBDATDIR	5	13
108	OCRA.14	TMRDIR	IOPB6	PBDATDIR	6	14
109	OCRA.15	TMRCLK	IOPB7	PBDATDIR	7	15
63	OCRB.0	ADCSOC	IOPC0	PCDATDIR	0	8
64	SYSCLR.7–6‡					
	0 0	IOPC1		PCDATDIR	1	9
	0 1	WDCLK		—	—	—
	1 0	SYSCLK		—	—	—
	1 1	CPUCLK		—	—	—
65	OCRB.2	IOPC2	XF	PCDATDIR	2	10
66	OCRB.3	IOPC3	$\overline{\text{BI}}\text{O}$	PCDATDIR	3	11
67	OCRB.4	CAP1/QEP1	IOPC4	PCDATDIR	4	12
68	OCRB.5	CAP2/QEP2	IOPC5	PCDATDIR	5	13
69	OCRB.6	CAP3	IOPC6	PCDATDIR	6	14
70	OCRB.7	CAP4	IOPC7	PCDATDIR	7	15

† Valid only if the I/O function is selected on the pin.

‡ SCR.7–6 represents bits 7 and 6 in the system control register (see section 3.2.1, *System Control Register*, on page 3-6).

2.4.2 Description of Group 2 Shared I/O Pins

Group 2 shared pins belong to peripherals which have built-in general purpose I/O capability. Control and configuration for these pins is achieved by setting appropriate bits within the control and configuration registers of the peripherals. Table 2–4 lists the Group 2 shared pins.

Table 2–4. Group 2 Shared Pins

Pin #	Primary Function	Register	Address	Peripheral Module
43	SCIRXD	SCIPC2	705Eh	SCI
44	SCITXD	SCIPC2	705Eh	SCI
45	SPISIMO	SPIPC2	704Eh	SPI
48	SPISOMI	SPIPC2	704Eh	SPI
49	SPICLK	SPIPC1	704Dh	SPI
51	SPISTE	SPIPC1	704Dh	SPI
54	XINT2	XINT2CR	7078h	External interrupts
55	XINT3	XINT3CR	707Ah	External interrupts

For information on:

- Serial communications interface (SCI) – see Chapter 8
- Serial peripheral interface (SPI) – see Chapter 9
- External Interrupts – see section 2.5.7

2.4.3 Digital I/O Control Registers

Table 2–5 lists the registers available to the digital I/O module. As with other '240 peripherals, the registers are memory mapped to the data space.

Table 2–5. Addresses of Digital I/O Control Registers

Address	Register	Name	Page
7090h	OCRA	I/O mux control register A	2-22
7092h	OCRB	I/O mux control register B	2-23
7098h	PADATDIR	I/O port A data and direction register	2-24
709Ah	PBDATDIR	I/O port B data and direction register	2-25
709Ch	PCDATDIR	I/O port C data and direction register	2-26

I/O MUX control registers

Figure 2–7. I/O MUX Control Register A (OCRA) — Address 7090h

15	14	13	12	11	10	9	8
CRA.15	CRA.14	CRA.13	CRA.12	CRA.11	CRA.10	CRA.9	CRA.8
RW–0	RW–0	RW–0	RW–0	RW–0	RW–0	RW–0	RW–0
7	6	5	4	3	2	1	0
Reserved				CRA.3	CRA.2	CRA.1	CRA.0
RW–0				RW–0	RW–0	RW–0	RW–0

Note: R = read access, W = write access, –0 = value after reset

Table 2–6. I/O MUX Control Register A (OCRA) Configuration

Bit #	Name.bit #	Pin function selected	
		(CRA.n = 1)	(CRA.n = 0)
0	CRA.0	ADCIN0	IOPA0
1	CRA.1	ADCIN1	IOPA1
2	CRA.2	ADCIN9	IOPA2
3	CRA.3	ADCIN8	IOPA3
8	CRA.8	PWM7/CMP7	IOPB0
9	CRA.9	PWM8/CMP8	IOPB1
10	CRA.10	PWM9/CMP9	IOPB2
11	CRA.11	T1PWM/T1CMP	IOPB3
12	CRA.12	T2PWM/T2CMP	IOPB4
13	CRA.13	T3PWM/T3CMP	IOPB5
14	CRA.14	TMRDIR	IOPB6
15	CRA.15	TMRCLK	IOPB7

Figure 2–8. I/O MUX Control Register B (OCRB) — Address 7092h

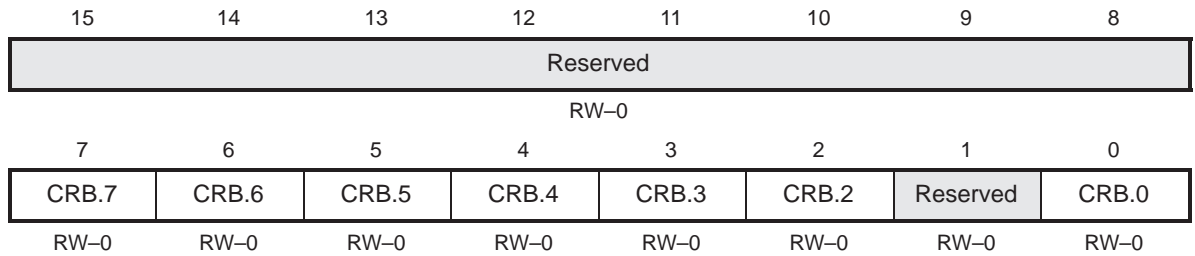

Note: R = read access, W = write access, –0 = value after reset

Table 2–7. I/O MUX Control Register B (OCRB) Configuration

Bit #	Name.bit #	Pin function selected	
		(CRB.n = 1)	(CRB.n = 0)
0	CRB.0	ADCSOC	IOPC0
2	CRB.2	IOPC2	XF
3	CRB.3	IOPC3	$\overline{\text{BIO}}$
4	CRB.4	CAP1/QEP1	IOPC4
5	CRB.5	CAP2/QEP2	IOPC5
6	CRB.6	CAP3	IOPC6
7	CRB.7	CAP4	IOPC7

I/O port data and direction registers

Figure 2–9. I/O Port A Data and Direction Register (PADATDIR) — Address 7098h

	15	14	13	12	11	10	9	8
Reserved				A3DIR	A2DIR	A1DIR	A0DIR	
				RW–0	RW–0	RW–0	RW–0	
	7	6	5	4	3	2	1	0
Reserved				IOPA3	IOPA2	IOPA1	IOPA0	
				RW–0	RW–0	RW–0	RW–0	

Note: R = read access, W = write access, –0 = value after reset, n = 0–3

Bits 15–12 Reserved

Bits 11–8 A3DIR–A0DIR. Port A direction control bits.

- 0 = Configure corresponding pin as an INPUT.
- 1 = Configure corresponding pin as an OUTPUT.

Bits 7–4 Reserved

Bits 3–0 IOPA3–IOPA0. Port A data bits.

If AnDIR = 0, then:

- 0 = Corresponding I/O pin is read as a LOW.
- 1 = Corresponding I/O pin is read as a HIGH.

If AnDIR = 1, then:

- 0 = Set corresponding I/O pin to an output LOW level.
- 1 = Set corresponding I/O pin to an output HIGH level.

Figure 2–10. I/O Port B Data and Direction Register (PBDATDIR) — Address 709Ah

15	14	13	12	11	10	9	8
B7DIR	B6DIR	B5DIR	B4DIR	B3DIR	B2DIR	B1DIR	B0DIR
RW–0	RW–0	RW–0	RW–0	RW–0	RW–0	RW–0	RW–0
7	6	5	4	3	2	1	0
IOPB7	IOPB6	IOPB5	IOPB4	IOPB3	IOPB2	IOPB1	IOPB0
RW–0	RW–0	RW–0	RW–0	RW–0	RW–0	RW–0	RW–0

Note: R = read access, W = write access, –0 = value after reset, n = 0–7

Bits 15–8 B7DIR–B0DIR. Port B direction control bits.

- 0 = Configure corresponding pin as an INPUT.
- 1 = Configure corresponding pin as an OUTPUT.

Bits 7–0 IOPB7–IOPB0. Port B data bits.

If BnDIR = 0, then:

- 0 = Corresponding I/O pin is read as a LOW.
- 1 = Corresponding I/O pin is read as a HIGH.

If BnDIR = 1, then:

- 0 = Set corresponding I/O pin to an output LOW level.
- 1 = Set corresponding I/O pin to an output HIGH level.

Figure 2–11. I/O Port C Data and Direction Register (PCDATDIR) — Address 709Ch

15	14	13	12	11	10	9	8
C7DIR	C6DIR	C5DIR	C4DIR	C3DIR	C2DIR	C1DIR	C0DIR
RW–0	RW–0	RW–0	RW–0	RW–0	RW–0	RW–0	RW–0
7	6	5	4	3	2	1	0
IOPC7	IOPC6	IOPC5	IOPC4	IOPC3	IOPC2	IOPC1	IOPC0
RW–0	RW–0	RW–0	RW–0	RW–0	RW–0	RW–0	RW–0

Note: R = read access, W = write access, –0 = value after reset, n = 0–7

Bits 15–8 C7DIR–C0DIR. Port C direction control bits.

- 0 = Configure corresponding pin as an INPUT.
- 1 = Configure corresponding pin as an OUTPUT.

Bits 7–0 IOPC7–IOPC0. Port C data bits.

If CnDIR = 0, then:

- 0 = Corresponding I/O pin is read as a LOW.
- 1 = Corresponding I/O pin is read as a HIGH.

If CnDIR = 1, then:

- 0 = Set corresponding I/O pin to an output LOW level.
- 1 = Set corresponding I/O pin to an output HIGH level.

2.5 Interrupts

Interrupts are hardware or software-driven signals that cause the '240 to suspend its main program and execute a subroutine. Typically, interrupts are generated by hardware devices that need to give data to, or take data from, the '240 (for example, the A/D converter or event manager). Interrupts may also be used to signal that a particular event has taken place (for example, a timer has finished counting).

The '240 software-programmable interrupt structure supports flexible on-chip and external interrupt configurations to meet real-time interrupt-driven application requirements. The '240 recognizes three types of interrupt sources:

- Reset** (hardware- or software-initiated) is not arbitrated by the CPU and takes immediate priority over any other executing functions. All maskable interrupts are disabled until the reset service routine enables them.
- Hardware-generated interrupts** are requested by external pins or by on-chip peripherals. There are two types:
 - *External interrupts* are generated by one of five external pins corresponding to the interrupts XINT1, XINT2, XINT3, PDPINT, and NMI. The first four can be masked both by dedicated enable bits and by the CPU's interrupt mask register (IMR), which can mask each maskable interrupt line at the DSP core. NMI, which is not maskable, takes priority over peripheral interrupts and software-generated interrupts. It can be locked out only by an already executing NMI or a reset.
 - *Peripheral interrupts* are initiated internally by the following on-chip peripheral modules: the event manager, SPI, SCI, WD/RTI, and ADC. They can be masked both by enable bits for each event in each peripheral and by the CPU's interrupt mask register (IMR), which can mask each maskable interrupt line at the DSP core.
- Software-generated interrupts** are requested by:
 - *INTR instruction*. This instruction allows initialization of any '240 interrupt with software. Its operand indicates to which interrupt vector location the CPU branches. This instruction globally disables maskable interrupts (sets the INTM bit to 1).
 - *NMI instruction*. This instruction forces a branch to interrupt vector location 24h, the same location used for the nonmaskable hardware interrupt NMI. NMI can be initiated by driving the NMI pin low or by executing an NMI instruction. This instruction globally disables maskable interrupts.

- *TRAP instruction.* This instruction forces the CPU to branch to interrupt vector location 22h. The TRAP instruction does not disable maskable interrupts (INTM is not set to 1); thus when the CPU branches to the interrupt service routine, that routine can be interrupted by the maskable hardware interrupts.
- *An emulator trap.* This interrupt can be generated with either an INTR instruction or a TRAP instruction.

Each of the '240 interrupts, whether hardware or software, can be placed in one of the following two categories:

- **Maskable interrupts.** These are hardware interrupts that can be blocked (masked) or enabled (unmasked) by software.
- **Nonmaskable interrupts.** These are interrupts that cannot be blocked. The '240 always responds to this type of interrupt and branches from the main program to a subroutine. The '240 nonmaskable interrupts include all software interrupts and three external hardware interrupts: reset (\overline{RS}), power-on reset ($\overline{PORESET}$) and NMI. Note that although \overline{RS} and $\overline{PORESET}$ are always active low, NMI has programmable polarity.

For information about the reset signal and its effects on the '240, see section 2.5.1, *Resets*, on page 2-31, section 3.3.3, *Exiting the Power-Down Modes*, on page 3-12, and section 5.2.1, *WD Timer*, on page 5-6.

The 'C2xx CPU offers 32 interrupt vector locations (0000–003E). These vectors consists of hardware and software interrupt vectors. The six hardware maskable interrupts, INT1–INT6 have been expanded using a system module. This expansion is required to service all interrupts from '240 peripherals. Table 2–8 describes the CPU interrupt grouping, along with peripheral interrupt vectors.

Table 2–11 summarizes the interrupts available on the '240. Other maskable interrupts are available through on-chip peripherals. The relationship between the maskable CPU interrupts (INT1–INT6) and the maskable peripheral interrupts is included in this section; however, for details on the peripheral interrupts available on a specific '24x device, see the data sheet for that device.

Table 2–8. '240 DSP Core Interrupt Locations and Priorities

K†	Vector Location	Name	Priority	Function
0	0h	\overline{RS}	1 (highest)	Hardware reset (nonmaskable)
1	2h	INT1	4	Maskable interrupt level #1‡
2	4h	INT2	5	Maskable interrupt level #2‡
3	6h	INT3	6	Maskable interrupt level #3‡
4	8h	INT4	7	Maskable interrupt level #4‡
5	Ah	INT5	8	Maskable interrupt level #5‡
6	Ch	INT6	9	Maskable interrupt level #6‡
7	Eh		10	Reserved
8	10h	INT8	–	User-defined software interrupt
9	12h	INT9	–	User-defined software interrupt
10	14h	INT10	–	User-defined software interrupt
11	16h	INT11	–	User-defined software interrupt
12	18h	INT12	–	User-defined software interrupt
13	1Ah	INT13	–	User-defined software interrupt
14	1Ch	INT14	–	User-defined software interrupt
15	1Eh	INT15	–	User-defined software interrupt
16	20h	INT16	–	User-defined software interrupt
17	22h	TRAP	–	TRAP instruction vector
18	24h	NMI	3	Nonmaskable interrupt
19	26h		2	Reserved
20	28h	INT20	–	User-defined software interrupt
21	2Ah	INT21	–	User-defined software interrupt
22	2Ch	INT22	–	User-defined software interrupt

† The K value is the operand used in an INTR instruction that branches to the corresponding interrupt vector location.

‡ Maskable interrupts are customized for each 'C24x DSP device with additional interrupt expansion logic.

Table 2–8. '240 DSP Core Interrupt Locations and Priorities (Continued)

K†	Vector Location	Name	Priority	Function
23	2Eh	INT23	–	User-defined software interrupt
24	30h	INT24	–	User-defined software interrupt
25	32h	INT25	–	User-defined software interrupt
26	34h	INT26	–	User-defined software interrupt
27	36h	INT27	–	User-defined software interrupt
28	38h	INT28	–	User-defined software interrupt
29	3Ah	INT29	–	User-defined software interrupt
30	3Ch	INT30	–	User-defined software interrupt
31	3Eh	INT31	–	User-defined software interrupt

† The K value is the operand used in an INTR instruction that branches to the corresponding interrupt vector location.

‡ Maskable interrupts are customized for each 'C24x DSP device with additional interrupt expansion logic.

2.5.1 Resets

The reset operation ensures an orderly startup sequence for the device. There are five possible causes of a reset, as shown in Figure 2–12. Three of these causes are internally generated; the other two causes, \overline{RS} pin and $\overline{PORESET}$ pin, are controlled externally.

Figure 2–12. Reset Signals

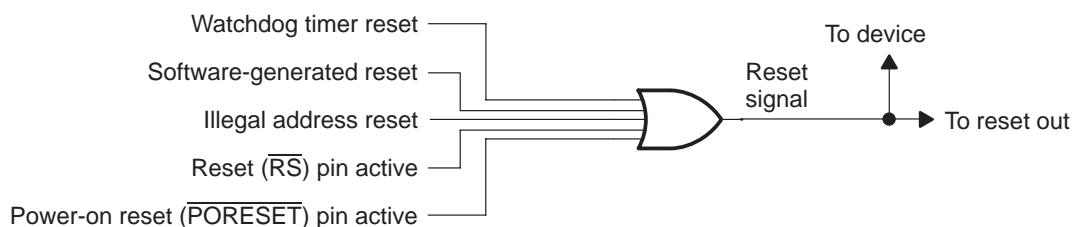

A reset pin generates a nonmaskable external interrupt that can be used at any time to put the '240 into a known state. Reset is the highest priority interrupt; no other interrupt takes precedence over a reset.

Reset is typically applied after power up when the machine is in an unknown state. Because the reset signal aborts memory operations and initializes status bits, the system should be reinitialized after each reset.

The NMI interrupt can be used for soft resets because it neither aborts memory operations nor initializes status bits.

The five possible reset signals are generated as follows:

- ❑ **Watchdog timer reset.** A watchdog timer generated reset occurs if the watchdog timer overflows or an improper value is written to either the watchdog key register or the watchdog control register. (Note that when the device is powered on, the watchdog timer is automatically active.)
- ❑ **Software-generated reset.** This is implemented with the system control register (SYSSR). Clearing the RESET0 bit (bit14) or setting the RESET1 bit (bit15) causes a system reset.
- ❑ **Illegal Address.** The system and peripheral module control register frame address map contains unimplemented address locations in the ranges labeled reserved. Any access to an address located in the Reserved ranges will generate an illegal-address reset.
- ❑ **Reset pin active.** To generate an external reset pulse on the \overline{RS} pin, a low-level pulse duration of as little as a few nanoseconds is usually effective; however, pulses of one SYCLK cycle are necessary to ensure that the device recognizes the reset signal.
- ❑ **Power-on Reset pin active.** To generate a power-on reset pulse on the $\overline{PORESET}$ pin, a low-level pulse of one SYCLK cycle is necessary to ensure that the device recognizes the reset signal.

Once a reset source is activated, the external \overline{RS} pin is driven (active) low for a minimum of eight SYCLK cycles. This allows the '240 to reset external devices connected to the \overline{RS} pin. (The \overline{RS} pin is an open-collector I/O pin and must have a pullup resistor attached.) Additionally, if the \overline{RS} pin is held low, the reset logic holds the device in a reset state for as long as the \overline{RS} pin is held low.

When a reset signal is received, the program determines the source of the reset by reading the contents of the system status register (SSR). The SSR contains one status bit for each of the four internal sources that can cause a reset. During a reset, the RAM contents remain unchanged, and all control bits that are affected by a reset are initialized.

The occurrence of a reset condition causes the '240 to terminate execution and affects various registers and status bits. During a reset, RAM contents remain unchanged, and all control bits that are affected by a reset are initialized. Processor execution begins at location 0, which normally contains a branch instruction to the system initialization routine.

In the case of a power-on reset, the PLL control register bits are initialized to zero. Your program must recognize power-on resets and configure the PLL for correct operation.

Your program can check the power-on reset flag (PORST flag, SYSSR.15), the illegal address flag (ILL ADDR flag, SYSSR.12), the software reset flag (SWRST flag, SYSSR.10), and the watchdog reset flag (WDRST flag, SYSSR.9) to determine the source of the reset. A reset does not clear these flags. The \overline{RS} and $\overline{PORESET}$ pins must be held low until the clock signal is valid and CVdd/DVdd is within operating range. In addition, $\overline{PORESET}$ must be driven low when CVdd/DVdd drops below the minimum operating range.

When a '240 reset occurs, the following actions take place:

- A logic 0 is loaded into the CNF (configuration control) bit in status register ST1; this maps dual-access RAM block 0 into the data space.
- The program counter is cleared to 0.
- The INTM (interrupt mode) bit is set to 1, disabling all maskable interrupts. (\overline{RS} and NMI are not maskable.) Also, the interrupt flag register (IFR) and interrupt mask register (IMR) are cleared.
- The status bits are loaded with the following values: OV = 0, XF = 1, SXM = 1, PM = 0, CNF = 0, INTM = 1, and C = 1. (The other status bits remain undefined and should be initialized after a reset.)
- The global memory allocation register (GREG) is cleared to make all memory local.
- The repeat counter (RPTC) is cleared.
- The wait states (if the device has an external memory interface) are set for the maximum duration.
- The peripheral register bits are initialized as described in their respective chapters.

No other CPU registers or status bits (such as the accumulator, the DP, the ARP, and the auxiliary registers) are initialized.

After $\overline{\text{PORST}}$ goes high, all I/O pins assume high impedance and the PLL/CLK register bits are set to reset values. The $\overline{\text{PORST}}$ signal decides the reset state of the I/O pins and PLL/CLK bits, irrespective of the $\overline{\text{RS}}$ signal. $\overline{\text{PORST}}$ should go high before the $\overline{\text{RS}}$ signal goes inactive to ensure that reset conditions are well defined.

The I/O pins and PLL/CLK bits are in their previous state on $\overline{\text{PORST}}$ low (or undefined on power-up) until $\overline{\text{PORST}}$ is driven high.

$\overline{\text{RS}}$ is an I/O pin, unlike $\overline{\text{PORST}}$, which is an input only. After reset, the $\overline{\text{RS}}$ pin functions as an output to internal reset signals such as watchdog.

2.5.2 Non-Maskable Interrupts (NMI) — Hardware and Software

Non-maskable interrupts can be generated by hardware or software.

Hardware generated

The NMI interrupt is used as a soft reset. Unlike a hardware reset, NMI neither affects any of the modes of the device nor aborts a currently active instruction or memory operation. Although NMI uses the same logic as the maskable interrupts, it is not maskable. NMI happens regardless of the value of the INTM bit, and there is no mask bit for NMI. This interrupt can only be locked out by an already executing NMI or a reset. When NMI is activated (either by the NMI pin or by the NMI instruction), the processor switches program control to vector location 24h. In addition, maskable interrupts are disabled: the INTM bit of status register ST0 is set to 1.

Note that although $\overline{\text{RS}}$ and $\overline{\text{PORESET}}$ are always active low, NMI has programmable polarity. For more information, see section 2.6.1, *External Interrupt Control Registers*, on page 2-67.

Software generated

Software interrupts (which are inherently nonmaskable) are requested by the following instructions:

- **INTR.** This instruction allows you to initiate any '240 interrupt, including user-defined interrupts INT8–INT16 and INT20–INT31. The instruction operand (K) indicates which interrupt vector location the CPU branches to. Table 2–11 (page 2-44) shows the operand K that corresponds to each vector location. When an INTR interrupt is acknowledged, the interrupt mode (INTM) bit of status register ST1 is set to 1 to disable maskable interrupts.

- ❑ **NMI.** This instruction forces a branch to interrupt vector location 24h, the same location used for the nonmaskable hardware interrupt NMI. Thus, you can either initiate NMI by driving the NMI pin active or by executing an NMI instruction. When the NMI instruction is executed, INTM is set to 1 to disable maskable interrupts.
- ❑ **TRAP.** This instruction forces the CPU to branch to interrupt vector location 22h. The TRAP instruction does not disable maskable interrupts (INTM is not set to 1); thus when the CPU branches to the interrupt service routine, that routine can be interrupted by the maskable hardware interrupts.
- ❑ **EMULATOR TRAP.** This interrupt can be generated with either an INTR instruction or a TRAP instruction.

After acknowledging a nonmaskable interrupt, the CPU:

- 1) Stores the program counter (PC) value (the return address) to the top of the hardware stack
- 2) Loads the PC with the address of the interrupt vector
- 3) Fetches the branch instruction that you stored at the vector location
If the interrupt was a hardware interrupt or was requested by either the INTR or NMI instructions, the CPU sets the INTM bit to 1 to disable maskable interrupts.
- 4) Executes the branch, which leads it to the address of your ISR
- 5) Executes the ISR until a return instruction concludes the ISR
If INTM is 1, all maskable interrupts are disabled during the execution of the ISR.
- 6) Pops the return address off the stack and into the PC
- 7) Continues executing the main program

To determine which vector address has been assigned to each of the interrupts, refer to Table 2–11, '*240 Interrupt Locations and Priorities*', on page 2-44. Each interrupt address has been spaced apart by two locations so that two-word branch instructions can be accommodated in those locations.

2.5.3 Interrupt Structure — Detailed Description

All the hardware interrupt lines of the CPU (DSP core) are given a priority rank from 1 to 10 (1 being highest). When more than one of these hardware interrupts is pending acknowledgment, the interrupt of highest rank gets acknowledged first. The others are acknowledged in order after that. Of those ten lines, six are for maskable interrupt lines (INT1–INT6) and one is for the nonmaskable interrupt (NMI) line. INT1–INT6 and NMI have the priorities shown in Table 2–9.

The CPU provides six maskable interrupt levels, INT1, INT2, INT3, INT4, INT5, and INT6. Because a '240 device can have more than six maskable interrupt sources, each of the six interrupt levels can be shared by multiple interrupt sources. Figure 2–13 on page 2-38 illustrates the structure used for receiving and acknowledging maskable interrupts for CPU interrupt level 1. The figure shows seven interrupt sources (XINT1, XINT2, XINT3, SPI, SCI RX, SCI TX and RTI) sharing the interrupt level INT1. A similar situation exists for the other levels (INT2–INT6).

Table 2–9. Interrupt Priorities at the Level of the DSP Core

Priority at the DSP Core	Interrupt
1	Reset
2	TI reserved†
3	NMI
4	INT1
5	INT2
6	INT3
7	INT4
8	INT5
9	INT6
10	TI Reserved†

† TI reserved means that the address space is reserved for Texas Instruments Incorporated.

Inputs to interrupt lines are controlled by the system module and the event manager as summarized in Table 2–10, and shown in Figure 2–14 on page 2-40.

Table 2–10. Interrupt Lines Controlled by the System Module and Event Manager

Interrupt Line	Peripheral
INT1 INT5 INT6 NMI	System Module
INT2 INT3 INT4	Event Manager

Each of the interrupt sources has its own control register with a flag bit and a mask bit. When an interrupt signal is received, the flag bit in the corresponding control register is set, indicating that the interrupt has been requested. If the mask bit is also set, a signal is sent to arbitration logic, which may simultaneously receive similar signals from one or more other control registers.

The arbitration logic compares the priority level of competing interrupt requests, and it passes the interrupt of highest priority to the CPU. The interrupt flag in the CPU's IFR that corresponds to the interrupt priority level on which the request was received is set. This indicates that the interrupt is pending. If the corresponding IMR bit is 1 and the INTM bit is 0, the CPU acknowledges the interrupt and executes the interrupt service routine (ISR).

Figure 2–13. Maskable Interrupt Structure For CPU Interrupt Level 1

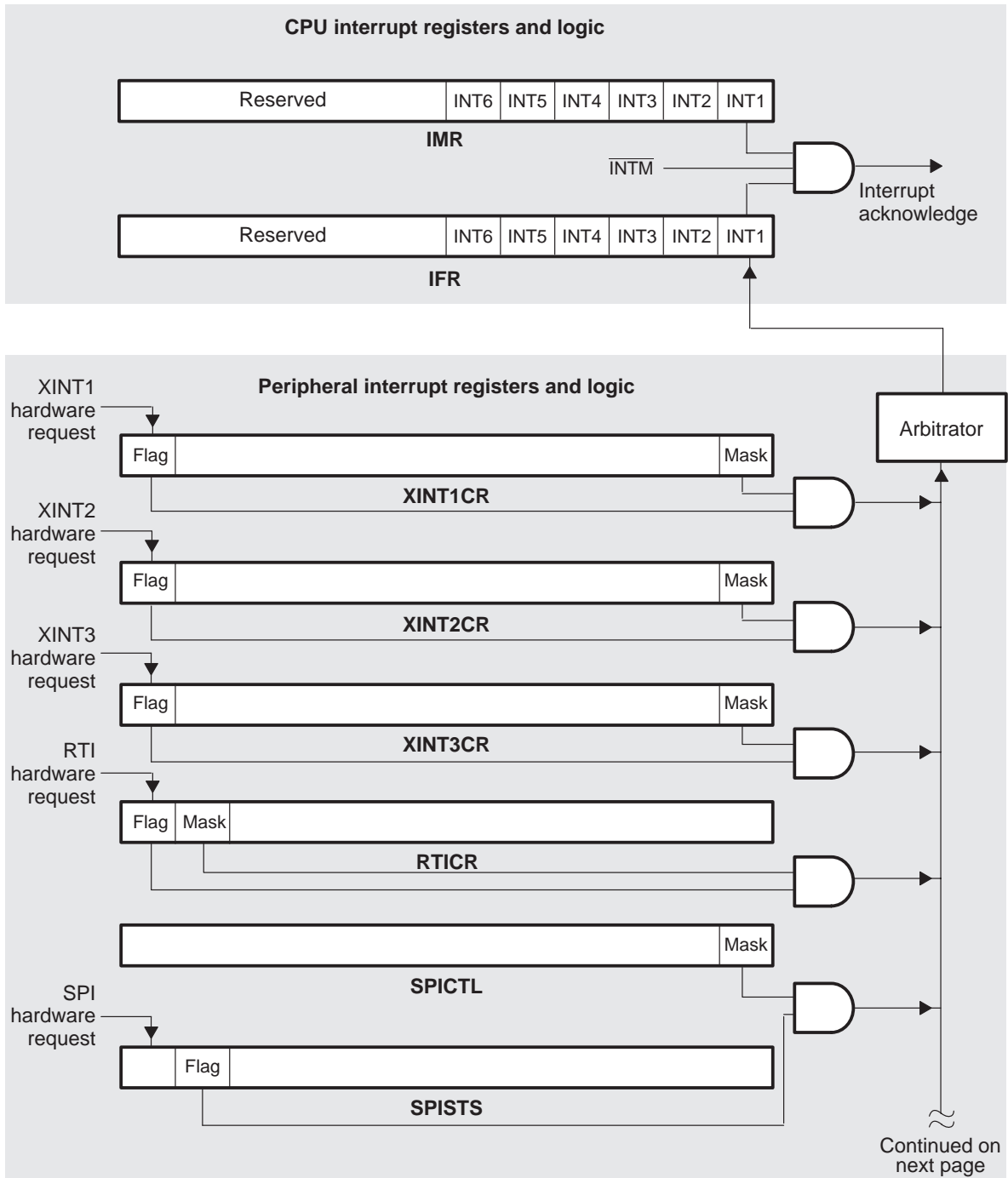
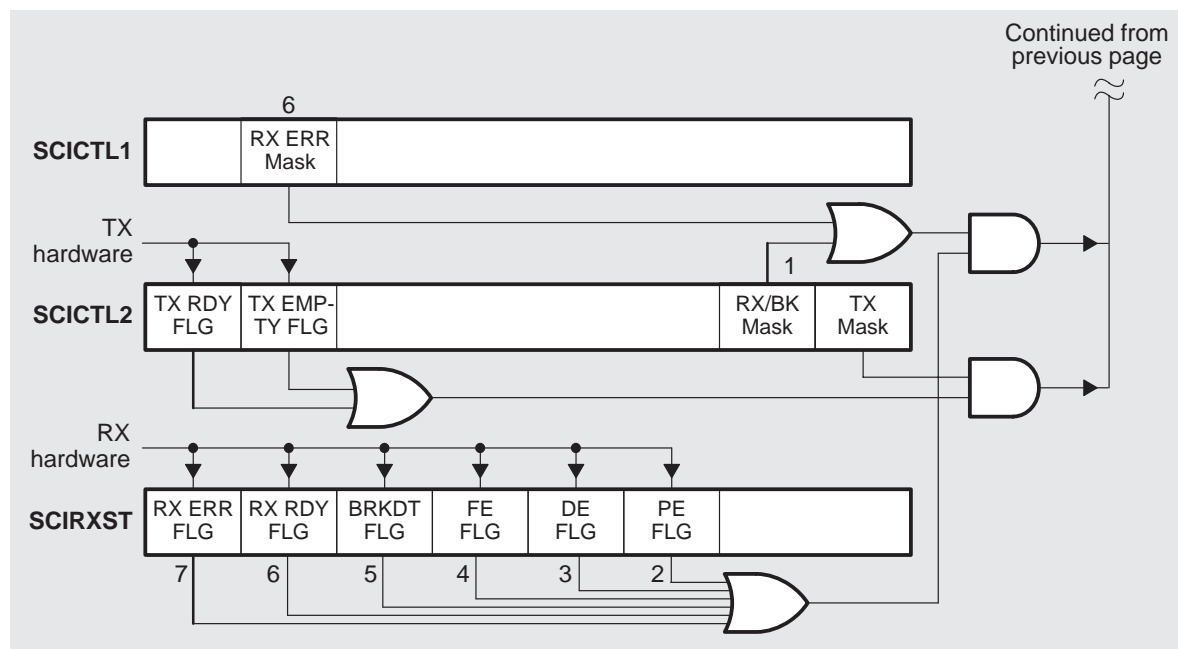

Figure 2–13. Maskable Interrupt Structure for CPU Interrupt Level 1 (Continued)



2.5.4 Interrupt Structure — Priority and Ranking

At the level of the system module and the event manager, each of the maskable interrupt lines (INT1–INT6) is connected to multiple maskable interrupt sources. Sources connected to interrupt line INT1 are called Level 1 interrupts; sources connected to interrupt line INT2 are called Level 2 interrupts; and so on. For each interrupt line, the multiple sources also have a set priority ranking. The DSP core responds first to the interrupt request of the source with the highest priority.

Figure 2–14. DSP Interrupt Structure

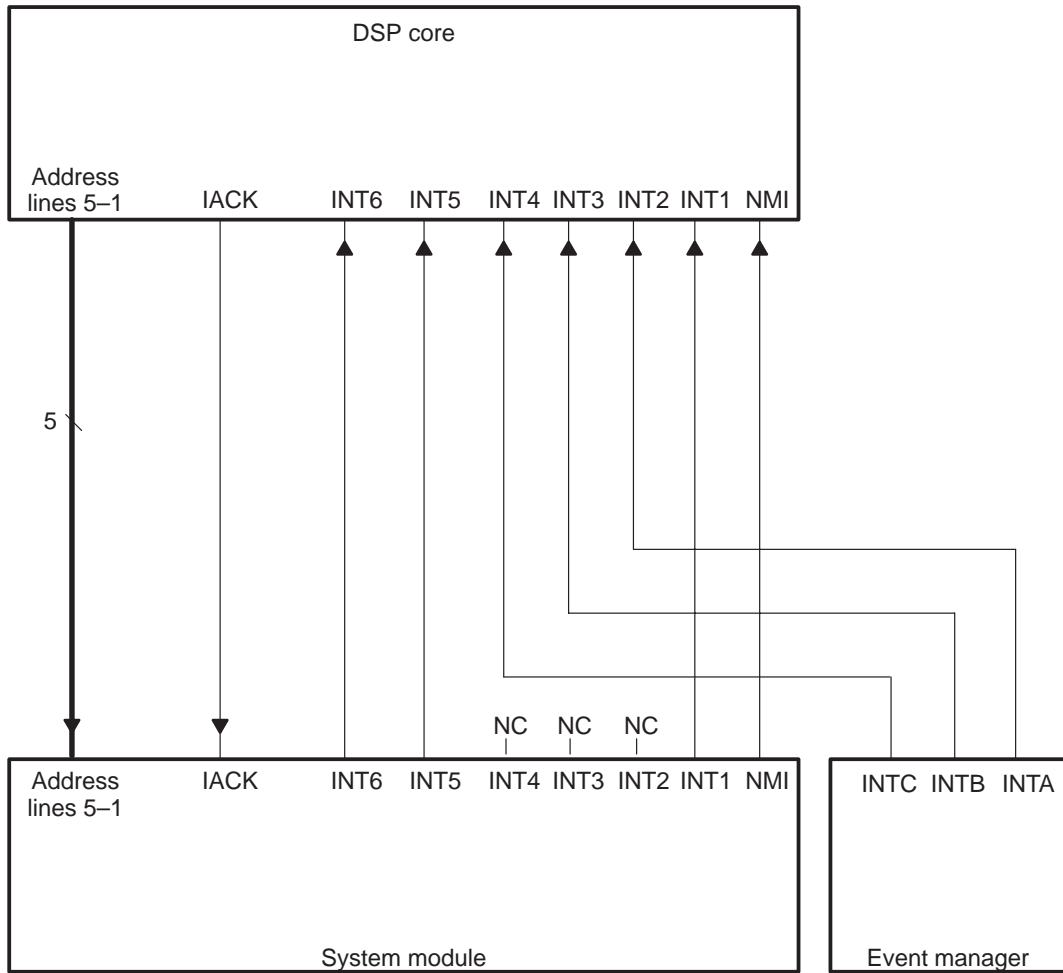

Figure 2–15 shows the sources and priority ranking for the interrupts controlled by the system module. Note that for each interrupt chain, the interrupt source of highest priority is at the top. Priority decreases from the top of the chain to the bottom.

Figure 2–16 on page 2-42 shows the interrupt sources and priority ranking for the event manager interrupts.

Figure 2–15. System-Module Interrupt Structure

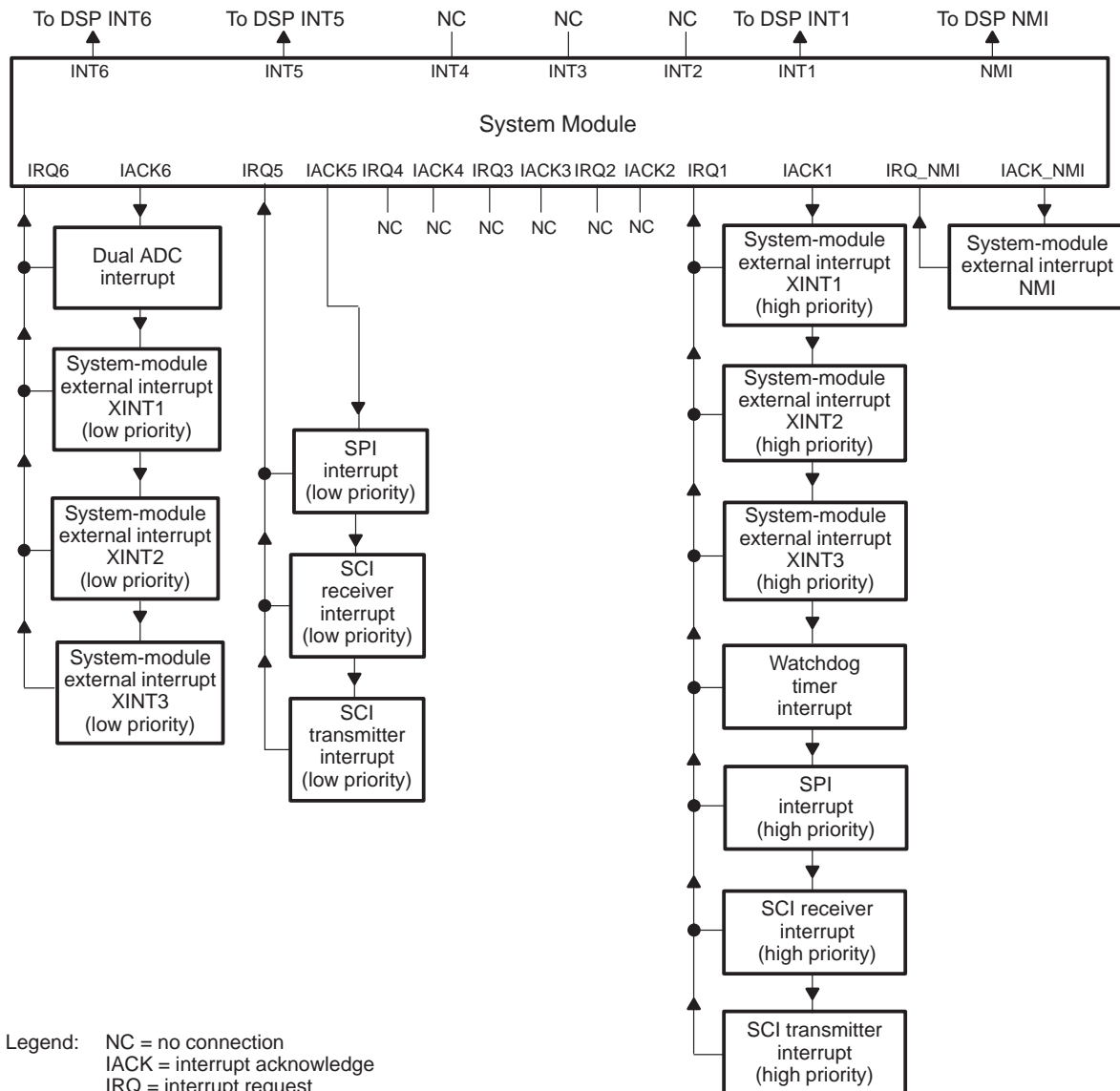
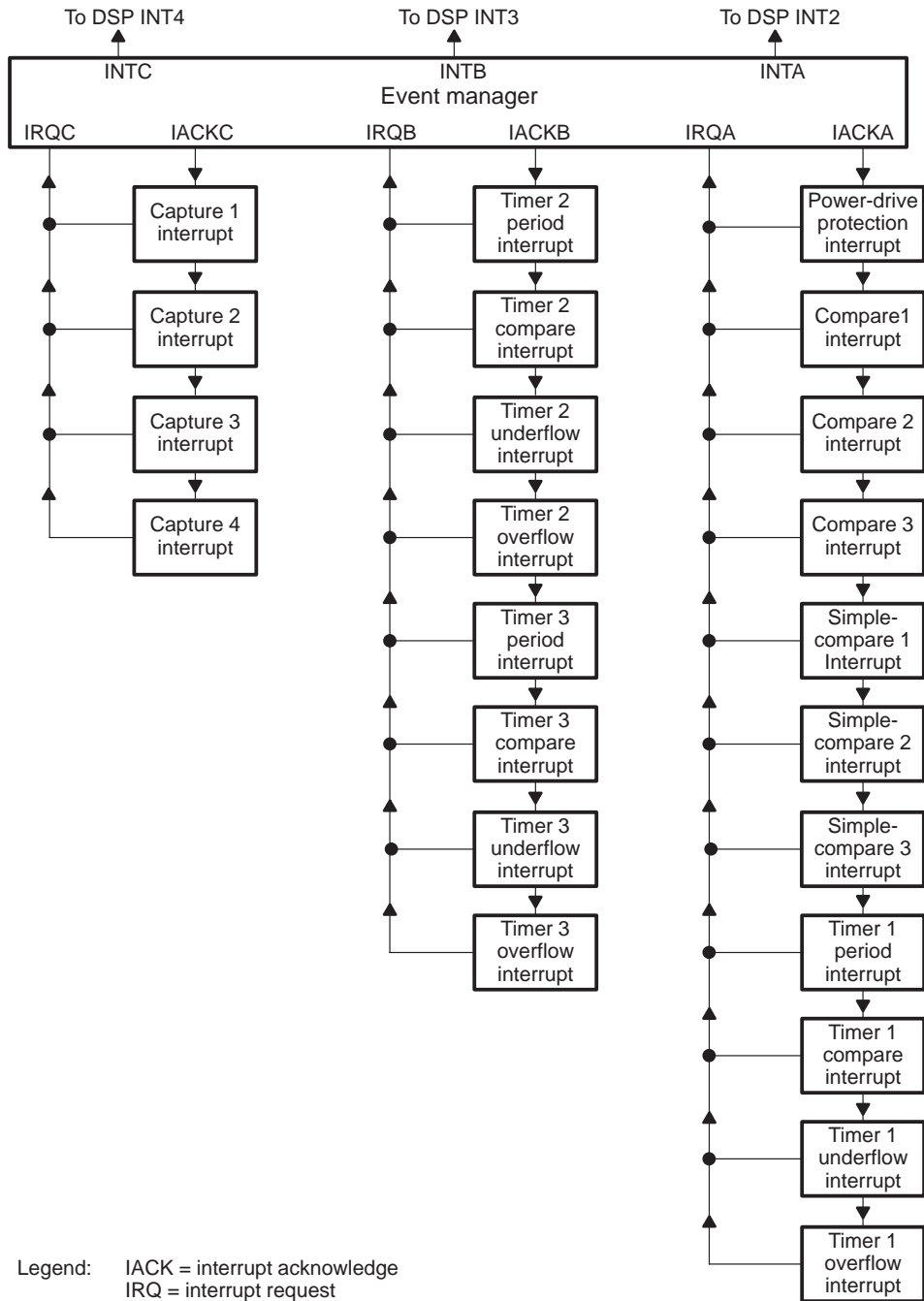

Figure 2–16. Event Manager Interrupt Structure



Each of the interrupt sources has its own control register with a flag bit and an enable bit. When an interrupt request is received, the flag bit in the corresponding control register is set. If the enable bit is also set, a signal is sent to arbitration logic, which may simultaneously receive similar signals from one or more other control registers. The arbitration logic compares the priority level of competing interrupt requests, and it passes the interrupt of highest priority to the CPU. The corresponding flag is set in the interrupt flag register (IFR), indicating that the interrupt is pending. The CPU then must decide whether to acknowledge the request. Maskable hardware interrupts are acknowledged only after the following conditions are met:

- ❑ **Priority is highest.** When more than one hardware interrupt is requested at the same time, the '240 services them according to the set priority ranking.
- ❑ **INTM bit is 0.** The interrupt mode (INTM) bit, bit 9 of status register ST0, enables or disables all maskable interrupts:
 - When INTM = 0, all unmasked interrupts are enabled.
 - When INTM = 1, all unmasked interrupts are disabled.
- ❑ **INTM is set to 1** automatically when the CPU acknowledges an interrupt (except when initiated by the TRAP instruction) and at reset. It can be set and cleared by software.
- ❑ **IMR mask bit is 1.** Each of the maskable interrupt lines has a mask bit in the interrupt mask register (IMR). To unmask an interrupt line, set its IMR bit to 1.

When the CPU acknowledges a maskable hardware interrupt, it jams the instruction bus with the INTR instruction. This instruction forces the program counter (PC) to the appropriate address from which the CPU fetches the software vector. This vector leads to an interrupt service routine.

Usually, the interrupt service routine reads the peripheral-vector-address offset from the peripheral-vector-address register (see Table 3–6) to branch to code that is meant for the specific interrupt source that initiated the interrupt request. The '240 includes a phantom-interrupt vector offset (0000h), which is a system interrupt integrity feature that allows a controlled exit from an improper interrupt sequence. If the CPU acknowledges a request from a peripheral when, in fact, no peripheral has requested an interrupt, the phantom-interrupt vector is read from the interrupt-vector register.

Table 2–11, *'240 Interrupt Locations and Priorities*, on page 2-44 summarizes the interrupt sources, overall priority, vector address/offset, source, and function of each interrupt available on the '240.

Table 2–11. '240 Interrupt Locations and Priorities

Interrupt Name	Overall Priority	DSP-Core Interrupt, and Address	Peripheral Vector Address	Peripheral Vector Address Offset	Maskable?	'x240 Source Peripheral Module	Function Interrupt
RS	1 Highest	RS 0000h	N/A		N	Core, SD	External, system reset (RESET)
RESERVED	2	INT7 0026h	N/A	N/A	N	DSP Core	Emulator trap
NMI	3	NMI 0024h	N/A	0002h	N	Core, SD	External user interrupt
XINT1	4			0001h	Y	SD	High-priority external user interrupts
XINT2	5			0011h			
XINT3	6			001Fh			
SPIINT	7	INT1 0002h	SYSIVR (701Eh)	0005h	Y	SPI	High-priority SPI interrupt
RXINT	8	(System)		0006h	Y	SCI	SCI receiver interrupt (high priority)
TXINT	9			0007h	Y	SCI	SCI transmitter interrupt (high priority)
WDTINT	10			0010h	Y	WDT	Watchdog timer interrupt
PDPINT	11			0020h	Y	External	Power-drive protection interrupt
CMP1INT	12			0021h	Y	EV.CMP1	Full compare 1 interrupt
CMP2INT	13			0022h	Y	EV.CMP2	Full compare 2 interrupt
CMP3INT	14			0023h	Y	EV.CMP3	Full Compare 3 interrupt
SCMP1INT	15	INT2 0004h		0024h	Y	EV.CMP4	Simple compare 1 interrupt
SCMP2INT	16	(Event Manager Group A)	EVIVRA (7432h)	0025h	Y	EV.CMP5	Simple compare 2 interrupt
SCMP3INT	17			0026h	Y	EV.CMP6	Simple compare 3 interrupt
TPINT1	18			0027h	Y	EV.GPT1	Timer1-period interrupt
TCINT1	19			0028h	Y	EV.GPT1	Timer1-compare interrupt
TUFINT1	20			0029h	Y	EV.GPT1	Timer1-underflow interrupt
TOFINT1	21			002Ah	Y	EV.GPT1	Timer1-overflow interrupt

Table 2–11. '240 Interrupt Locations and Priorities (Continued)

Interrupt Name	Overall Priority	DSP-Core Interrupt, and Address	Peripheral Vector Address	Peripheral Vector Address Offset	Maskable?	'x240 Source Peripheral Module	Function Interrupt
TPINT2	22			002Bh	Y	EV.GPT2	Timer2-period interrupt
TCINT2	23	INT3		002Ch	Y	EV.GPT2	Timer2-compare interrupt
TUFINT2	24	0006h		002Dh	Y	EV.GPT2	Timer2-underflow interrupt
TOFINT2	25			002Eh	Y	EV.GPT2	Timer2-overflow interrupt
TPINT3	26		EVIVRB (7433h)	002Fh	Y	EV.GPT3	Timer3-period interrupt
TCINT3	27	(Event Manager Group B)		0030h	Y	EV.GPT3	Timer3-compare interrupt
TUFINT3	28			0031h	Y	EV.GPT3	Timer3-underflow interrupt
TOFINT3	29			0032h	Y	EV.GPT3	Timer3-overflow interrupt
CAPINT1	30	INT4		0033h	Y	EV.CAP1	Capture 1 interrupt
CAPINT2	31	0008h	EVIVRC (7434h)	0034h	Y	EV.CAP2	Capture 2 interrupt
CAPINT3	32	(Event Manager Group C)		0035h	Y	EV.CAP3	Capture 3 interrupt
CAPINT4	33			0036h	Y	EV.CAP4	Capture 4 interrupt
SPIINT	34			0005h	Y	SPI	Low-priority SPI interrupt
RXINT	35	INT5	SYSIVR (701Eh)	0006h	Y	SCI	SCI receiver interrupt (low priority)
TXINT	36	(System)		0007h	Y	SCI	SCI transmitter interrupt (low priority)
ADCINT	37	INT6		0004h	Y	ADC	Analog-to-digital interrupt
XINT1	38	000Ch	SYSIVR (701Eh)	0001h	Y	External pins	Low-priority external user interrupts
XINT2	39	(System)		0011h	Y		
XINT3	40			001Fh	Y		
RESERVED	41	000Eh	N/A		Y	DSP Core	Used for analysis
TRAP	N/A	0022h	N/A		N/A		TRAP instruction vector
Phantom Interrupt Vector	N/A	N/A		0000h	N/A	CPU	Phantom interrupt vector
INT8 through INT16	N/A	0010h through 0020h		N/A	N/A	CPU	
INT20 through INT31	N/A	00028h through 0603Fh		N/A	N/A	CPU	Software interrupt vectors†

† For more information, refer to *TMS320F/C24x CPU and Instruction Set Reference Guide* (SPRU160); and *TMS320F243,F241,C242 DSP Controllers System and Peripherals Reference Guide* (SPRU276).

Note: Interrupts 1–6 are supported by the CPU's expanded system module to meet all 'F/C240 CPU interrupt needs.

2.5.5 Interrupt Operation: Detailed Description

The '240 handles interrupts in the following three phases:

- 1) **Receive interrupt request.** Suspension of the main program must be requested by software (program code) or hardware (a pin or an on-chip device).
- 2) **Acknowledge interrupt.** The '240 must acknowledge the interrupt request. If the interrupt is maskable, certain conditions must be met in order for the '240 to acknowledge it. For nonmaskable hardware interrupts and for software interrupts, acknowledgment is immediate.
- 3) **Execute interrupt service routine.** Once the interrupt is acknowledged, the '240 branches to its corresponding subroutine, called an interrupt service routine (ISR). The '240 follows the branch instruction you place at a predetermined address (the vector location) and executes the ISR you have written.

Figure 2–17. Interrupt Operation Flow Chart

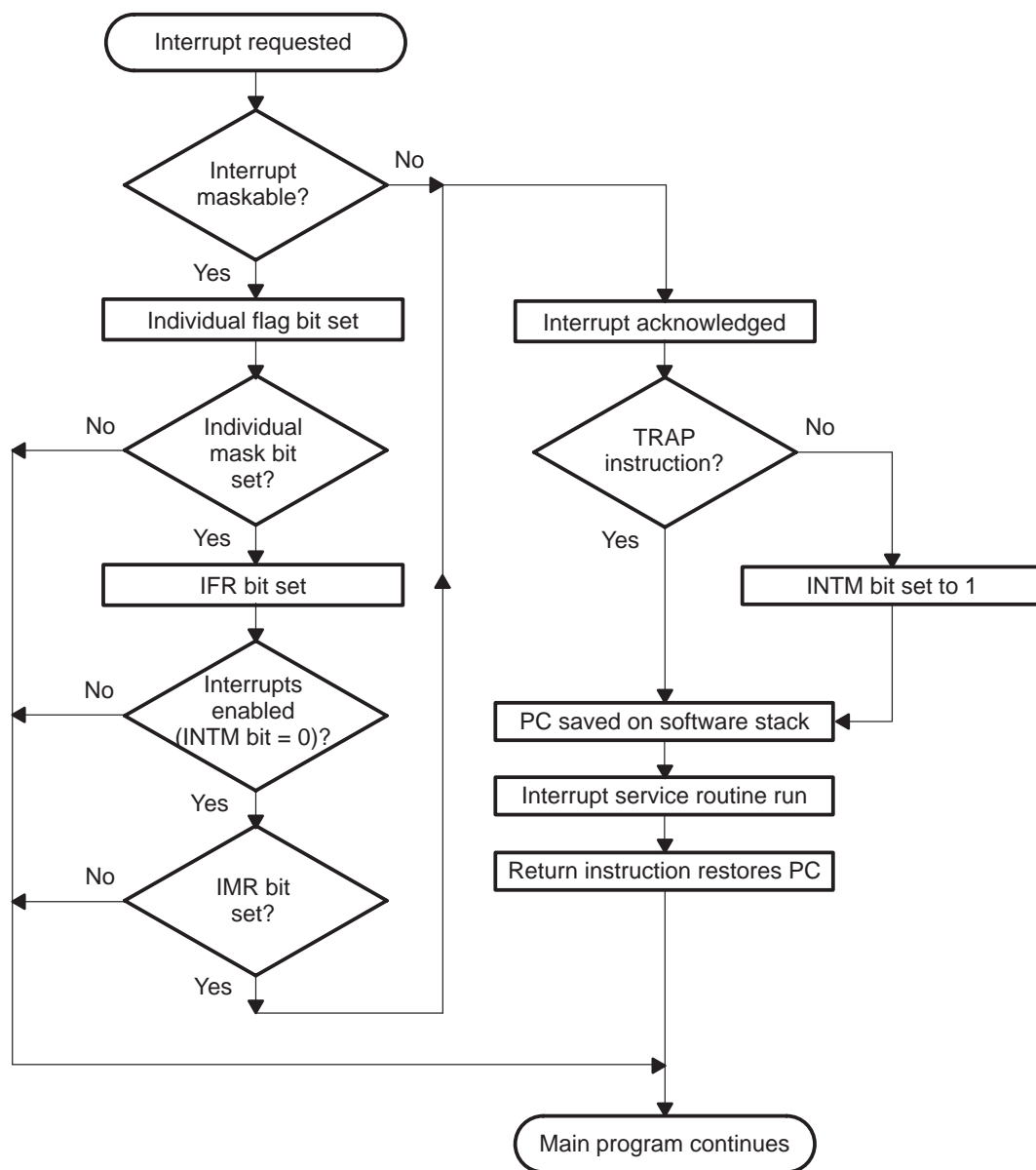

Acknowledging Maskable Interrupts

Software interrupts and nonmaskable hardware interrupts are acknowledged immediately. Maskable hardware interrupts are acknowledged only after certain conditions are met:

- ❑ **Priority is highest.** When more than one hardware interrupt is requested at the same time, the '240 services each interrupt according to a set priority ranking (see Figure 2–15 on page 2-41).
- ❑ **INTM bit is 0.** The interrupt mode (INTM) bit, bit 9 of status register ST0, enables or disables all maskable interrupts:
 - When INTM = 0, all unmasked interrupts are enabled.
 - When INTM = 1, all maskable interrupts are disabled.

INTM is set to 1 automatically when the CPU acknowledges an interrupt (except when initiated by the TRAP instruction). INTM can also be set to 1 by a hardware reset or by execution of a disable-interrupts instruction (SETC INTM). INTM is reset to 0 by executing the enable-interrupts instruction (CLRC INTM). INTM has no effect on reset, NMI, or software-interrupts. Also, INTM is unaffected by the LST (load status register) instruction.

INTM does not modify the interrupt mask register (IMR) or the interrupt flag register (IFR).

- ❑ **IMR mask bit is 1.** Each of the maskable interrupt levels has a mask bit in the IMR. To unmask an interrupt level, set its IMR bit to 1. For more details about the IMR, see *Interrupt Mask Register (IMR)* on page 2-66.

When the CPU acknowledges a maskable hardware interrupt, it jams the instruction bus with the INTR instruction. This instruction forces the PC to the appropriate address from which the CPU fetches the software vector.

Two-Part Interrupt Service Routine (ISR)

The 'C2xx CPU has six interrupt levels; however, '240 devices provide a means of creating more than six ISRs. Figure 2–18, *Interrupt Service Routine Flow Chart*, on page 2-49 illustrates the process of servicing an interrupt request.

For each of the six interrupt levels, the CPU branches to a corresponding general interrupt service routine (GISR). For example, when responding to an interrupt request on priority level INT1, the CPU branches to and executes GISR1. The GISR, after performing any necessary context saves, identifies and then branches to the specific interrupt service routine (SISR). The SISR performs the actions specific to the triggering interrupt and then returns program control to the interrupted program sequence.

Figure 2–18. Interrupt Service Routine Flow Chart

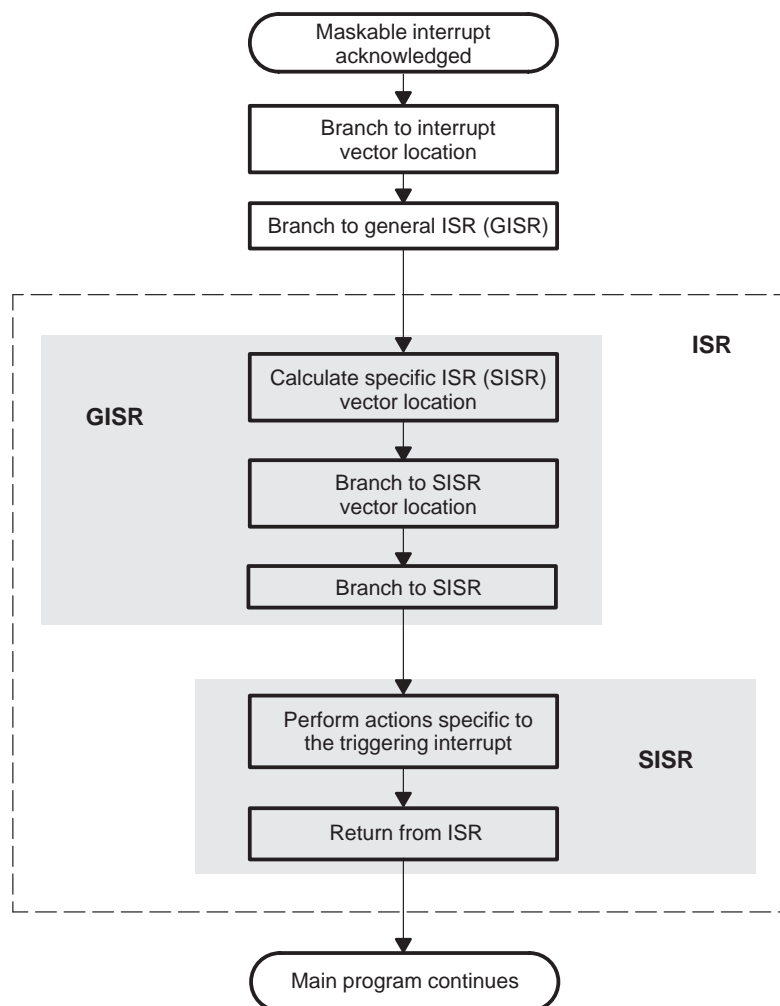

Branching to the GISR. Table 2–12, '*240 Maskable Interrupt Vector Table*', shows the addresses and contents of the interrupt vector locations for the maskable interrupt levels. (For a table with all interrupt vector locations, see Table 2–11 on page 2-44.) When an interrupt is acknowledged through one of these interrupt levels, the CPU branches to the corresponding vector address and follows the branch at that address to the GISR. For example, if an interrupt is acknowledged through INT3, the program counter (PC) value is stored to the stack, and then the PC is loaded with program-memory address 0006h. Locations 0006h and 0007h contain a branch instruction that takes the CPU to the GISR.

Table 2–12. '240 Maskable Interrupt Vector Table

Interrupt Level	Interrupt Vector Location	Contents of Vector Location
INT1	0002h	Branch to GISR1
INT2	0004h	Branch to GISR2
INT3	0006h	Branch to GISR3
INT4	0008h	Branch to GISR4
INT5	000Ah	Branch to GISR5
INT6	000Ch	Branch to GISR6

Branching to the SISR. When a peripheral interrupt request is acknowledged (this includes the external interrupt control registers), the peripheral generates a vector address offset (vector) that corresponds to this interrupt event. This vector is usually latched in the system interrupt vector register (SYSIVR), although some peripherals, including the event manager, may keep the vector in a register in the peripheral. The GISR must read the value stored in the IVR and use it to generate the branch target address to the SISR. Several methods of doing this are described in the section titled *Additional Tasks of ISRs*. Refer to Table 2–11 for details on the vector value for each interrupt event, and for the location of the IVR for each interrupt level.

Phantom Interrupt Vector

Note: IVR

For the following discussion, IVR represents any one of these registers: SYSIVR, EVIVRA, EVIVRB, EVIVRC.

The phantom interrupt vector is an interrupt system-integrity feature. In the event that an interrupt is acknowledged but no peripheral responds by loading an interrupt vector address offset value into the IVR, the phantom vector (0000h) is loaded into the IVR instead, so that the fault can be handled in a controlled manner.

Two causes of phantom interrupts are:

- Execution of the INTR instruction with an argument in the range of 1 to 6. This is a software request to service one of the six maskable interrupt levels (INT1, INT2, INT3, INT4, INT5, or INT6)
- A glitch on an interrupt request line

In either case, when the interrupt is acknowledged, no peripheral loads a vector into the IVR. Loading the IVR with the phantom interrupt vector ensures that the DSP branches to a known location.

Programming ISRs for Maskable Interrupts

The three methods for creating an interrupt service routine (ISR) for a maskable interrupt are:

- Method 1:** A typical ISR
- Method 2:** An ISR that is designed to reduce the latency between the time the interrupt is requested and the time the event-specific portion of the ISR is executed
- Method 3:** An ISR that has very little latency — used only if one peripheral interrupt source is connected to an interrupt request priority level or if only one of many interrupt sources connected to an interrupt request priority level is enabled

Method 1: Typical ISR

The method described here is the typical implementation of an ISR for the '240. Methods 2 and 3, described below are slightly more difficult to program. It is best to implement this typical ISR first and then develop a more complex routine if the latency for certain events is too high.

In Method 1, the ISR for a maskable interrupt is divided into two segments:

- 1) **General ISR (GISR).** When an interrupt on one of the six maskable interrupt levels (INT1–INT6) is acknowledged, the GISR reads the relevant interrupt vector register (IVR), shifts the value left by one bit, adds an offset to the value, and then branches to a peripheral interrupt vector table. From this table, it fetches and executes the appropriate branch to the specific ISR (SISR).
- 2) **Specific ISR (SISR).** The SISR performs actions specific to the event that caused the interrupt and then returns program control to the interrupted code sequence.

Table 2–13, *Example of Method 1 ISR*, on page 2-52 shows a typical implementation of an ISR.

Table 2–13. Example of Method 1 ISR

Cycle Count	Address	Assembly Language Code
		;CPU interrupt vector table

0	0006h	INT3 B ;Branch to address of general ISR
	0007h	GISR3 ;for INT3.

4	GISR3 Addr	GISR3 LACC xIVR,1 ;Load accumulator with ;contents of interrupt vector ;register (xIVR) shifted by 1.
4+n†	GISR3 Addr+1	ADD offset ;Add offset to accumulator.
5+n†	GISR3 Addr+2	BACC ;Branch to address in accumulator ;(2*IVR+offset).

		;Peripheral interrupt vector table

9+n†	2*IVR+offset (2*IVR+offset)+1	B ;Branch to specific ISR for SISRx ;event that requested interrupt.

13+n†	SISRx Addr	SISRx ... ;Perform event-specific actions.
	SISRx Addr+1	... ;...
 ;...
	SISRx Addr+n	RET ;Return from ISR.

† For the peripheral interface, n = 4; for the event manager, n = 1

In Table 2–13, *Example of Method 1 ISR*, the following events occur:

- 1) An acknowledged peripheral interrupt asserts INT3 and causes the device to enter its interrupt vector table at address 0006h.
- 2) From addresses 0006h and 0007h, the device reads a branch that leads it to GISR3.
- 3) GISR3 loads the accumulator with the contents of the relevant IVR shifted by 1 (that is, multiplied by 2). Note the following:
 - ❑ The LACC instruction uses direct addressing to access the IVR value. For this to work, the data page pointer (DP in status register ST0) must be set to point to the page in data memory that contains the IVR.

- ❑ You may want to save the accumulator value before loading the accumulator with the shifted IVR value.
 - ❑ The incoming vector has been multiplied by two because a peripheral interrupt vector table must support a 2-word branch instruction for each peripheral interrupt.
- 4) GISR3 adds an offset to the accumulator that corresponds to the start of the peripheral interrupt vector table. The accumulator now contains the address that needs to be accessed in the peripheral interrupt vector table.
 - 5) GISR3 branches to the address in the accumulator.
 - 6) From the peripheral interrupt vector location, the device reads a branch that leads to the SISR for the event that requested the interrupt.
 - 7) The SISR is executed. The SISR concludes with a return instruction, which returns program control to the interrupted code sequence.

Method 2: Minimum latency ISR for multiple events per interrupt level

This method is similar to Method 1, but has reduced latency because one of the branches (the branch to the peripheral interrupt vector table) is bypassed. Instead, the general ISR (GISR) branches directly to the specific ISR (SISR). To do this, the GISR shifts the value from the IVR by more than 2 and uses the result as the branch target. It may be difficult to locate all the SISRs in program space without leaving some holes in memory. It is best to use Method 1 initially and then Method 2 for some interrupts if the higher latency of Method 1 is unacceptable.

The Method 2 ISR is implemented as follows:

- 1) **General ISR (GISR).** When an interrupt on one of the six maskable interrupt levels (INT1–INT6) is acknowledged, the GISR reads the relevant interrupt vector register (IVR), shifts the value left by a predetermined amount, and then branches to the specific ISR (SISR). The shift amount is chosen such that the accumulator will contain the address of the SISR. For example, if three interrupt sources are tied to INT2 and the SISR for each of the events is not greater than 16 words long, then a shift of 4 is suitable.
- 2) **Specific ISR (SISR).** The SISR performs actions specific to the event that caused the interrupt and then returns program control to the interrupted code sequence.

An example of method 2 is shown in Table 2–14, *Example of Method 2 ISR*, on page 2-54.

Table 2–14. Example of Method 2 ISR

Cycle Count	Address	Assembly Language Code
		;CPU interrupt vector table

0	0004h	INT2 B ;Branch to GISR
	0005h	GISR2 ;for INT2.

4	GISR2 Addr	GISR2 LACC xIVR,shift ;Load accumulator with ;contents of interrupt vector ;register (xIVR) shifted by ;an amount that will result in ;SISRx address in accumulator.
4+n†	GISR2 Addr+1	BACC ;Branch to address in ;accumulator.

8+n†	SISRx Addr	SISRx ... ;Perform event-specific actions.
	SISRx Addr+1	... ;...
 ;...
	SISRx Addr+n	RET ;Return from ISR.

† For the peripheral interface, n = 4; for the event manager, n = 1.

In Table 2–14, *Example of Method 2 ISR*, the following events occur:

- 1) An acknowledged peripheral interrupt asserts INT2 and causes the device to enter it's interrupt vector table at address 0004h.
- 2) From addresses 0004h and 0005h, the device reads a branch that leads it to GISR2.
- 3) GISR2 loads the accumulator with the contents of the relevant IVR shifted by an amount that results in the accumulator holding the address of the SISR. Note the following:
 - The LACC instruction uses direct addressing to access the IVR value. For this to work, the data page pointer (DP in status register ST0) must be set to point to the page in data memory that contains the IVR.
 - You may want to save the accumulator value before loading the accumulator with the shifted IVR value.

- 4) GISR2 branches to the address in the accumulator (the start address of the SISR).
- 5) The SISR is executed. The SISR concludes with a return instruction, which returns program control to the interrupted code sequence.

Method 3: ISR for single event per interrupt level

A device can be configured such that only one event can assert a particular maskable interrupt. There are two configurations for this.

- In the first configuration, both of these conditions must be met:
 - Only one peripheral is connected to the maskable interrupt level (INT1, INT2, INT3, INT4, INT5, or INT6).
 - That one peripheral has only one event that can cause an interrupt request (and, thus, has only one interrupt vector).
- In the second configuration, only one of the many events tied to a particular interrupt priority level is enabled.

With either configuration, there is no need for a two-part ISR like the one in Method 1 or the one in Method 2. There is one simple ISR and thus, only one branch instruction. The address of the ISR is known; it does not have to be calculated in a routine. The GISR and the SISR become one in the same.

The following events occur during the routine described in Table 2–15, *Example of Method 3 ISR*, on page 2-56:

- 1) An acknowledged peripheral interrupt asserts INT1 and causes the device to enter its interrupt vector table at address 0002h.
- 2) From addresses 0002h and 0003h, the device reads a branch that leads it directly to the SISR.
- 3) The SISR is executed and concludes with a return instruction that returns program control to the interrupted code sequence.

Table 2–15. Example of Method 3 ISR

Cycle Count	Address	Assembly Language Code
		;CPU interrupt vector table

0	0002h	INT1 B ;Branch to ISR1.
	0003h	ISR1

4	SISRx Addr	ISR1 ... ;Perform event-specific actions.
	SISRx Addr+1	... ;...
 ;...
	SISRx Addr+n	RET ;Return from ISR.

Programming an ISR for Nonmaskable Interrupt (NMI)

Generally, there cannot be more than one event capable of generating an NMI request, and in cases where they do, they all share the same ISR. Thus, NMI does not require loading an interrupt vector register (IVR), and the branch at vector location 24h is the only branch necessary for the ISR.

An NMI can interrupt a maskable ISR after the vector has been loaded into the IVR but before the maskable ISR has read the IVR. Because NMI does not cause a loading of the IVR, an NMI does not cause overwriting of the maskable interrupt’s vector address offset. However, an enabled interrupt immediately following the NMI ISR could overwrite the value in the IVR before the interrupted ISR has read it. Therefore, the ISR for NMI must check the VECRD bit (bit 0) in the system status register (SSR). If VECRD = 1, a read of the IVR is pending, and the NMI ISR should not reenale maskable interrupts.

The ISR for NMI can be implemented as shown in Table 2–16, *Implementation of an ISR for NMI*, on page 2-57.

Table 2–16. Implementation of an ISR for NMI

Address	Assembly Language Code		
	; CPU interrupt vector table		
...		...	
0024h	NMI	B	;Branch to NMI ISR.
0025h		NMI_ISR	
...		...	
NMI ISR Addr	NMI_ISR	...	;Start of ISR
...		...	;Body of ISR
...		BIT SSR,15	;Test bit 0 (VECRD) of SYSSR0
...		RETC TC	;If set, return from ISR
...			;(without enabling interrupts)
...		CLRC INTM	;If not set, enable interrupts and
...		RET	;return from ISR.

Additional Tasks of ISRs

While performing the tasks requested by an interrupt, the ISR may also be:

- Saving and restoring register values
- Managing ISRs within ISRs

Saving and restoring register values

Only the incremented program counter value is stored automatically before the CPU enters an ISR. You must design the ISR to save and then restore any other important register values or control bit values. You can use a common routine or routines individualized for each interrupt to secure the context of the processor during interrupt processing.

You can manage stack storage as long as the stack does not exceed the memory space. This stack is also used for subroutine calls; the '240 supports subroutine calls within the ISR. The PSHD and POPD instructions can transfer data-memory values to and from the stack.

Managing ISRs within ISRs

The '240 hardware stack allows you to have ISRs within ISRs. When considering nesting ISRs like this, keep the following in mind:

- ❑ If you want the ISR to be interrupted by a maskable interrupt, the ISR must unmask the interrupt by setting the appropriate individual mask bit and the appropriate IMR bit and globally reenabling interrupts by clearing the INTM bit (CLRC INTM).
- ❑ The appropriate interrupt vector register must have been read by the GISR to obtain the *vector address offset* before globally reenabling interrupts. Otherwise, a subsequent interrupt can cause the old vector value to be overwritten.
- ❑ The hardware stack is limited to eight levels. Each time an interrupt is serviced or a subroutine is entered, the return address is pushed onto the hardware stack. This provides a way to return to the previous context after the interrupt service routine. The stack contains eight locations, allowing interrupts or subroutines to be nested up to eight levels deep. (One level of the stack is reserved for debugging, specifically for break-point/single-step operations. If debugging is not used, this extra level is available for internal use.) If your software requires more than eight levels of stack, you can use the POPD and PSHD instructions to extend the stack into data memory.
- ❑ You can avoid stack overflow by not nesting ISRs. The '240 has a feature that allows you to prevent unintentional nesting. If an interrupt occurs during the execution of a CLRC INTM instruction, the device always completes CLRC INTM as well as the following instruction before the pending interrupt is processed. This ensures that a return (RET) placed immediately after the CLRC INTM can be executed before the next interrupt is processed. The processor removes the previous return address from the stack before it adds the new return address.
- ❑ If you want an ISR to occur *within* the current ISR rather than after the current ISR, place the CLRC INTM instruction more than one instruction before the return (RET) instruction.

2.5.6 Interrupt Latency

The length of an interrupt latency—the delay between when an interrupt request is made and when it is serviced—depends on many factors. This section describes the factors that determine minimum latency and then describes factors that may cause additional latency. The maximum latency is a function of wait states and pipeline protection.

Interrupt latency on the '240 consists of the following components:

- Peripheral interface synchronization time
- CPU response time
- ISR branching time

Peripheral interface synchronization time

Peripheral interface synchronization time is the time it takes for the interrupt request from the peripheral to be recognized by the peripheral interface, arbitrated, and converted into a request to the DSP. This takes up to one SYSCLK cycle for internal interrupts from on-chip peripherals (peripheral bus operates at the SYSCLK rate). Therefore, it takes *two* CPUCLK cycles in divide-by-two clock mode, and *four* CPUCLK cycles in divide-by-four mode. External interrupts (NMI, INTx) have a two-SYSCLK-cycle synchronization delay.

Interrupt requests from the event manager peripheral are not arbitrated by the peripheral interface; there is a one-CPUCLK-cycle delay for the CPU to recognize the interrupt.

CPU response time

CPU response time is the time it takes for the CPU to recognize the enabled interrupt request, acknowledge the interrupt, clear its pipeline, and begin retrieving the first instruction from the CPU's interrupt vector table. The minimum CPU latency is *four* CPUCLK cycles. If a higher priority maskable interrupt is requested during this minimum latency period, it is masked until the ISR for the interrupt being serviced is completed. NMIs are not maskable and are serviced before the current ISR is completed.

Latency is longer if the interrupt request occurs during multicycle operations or other operations that cannot be interrupted. If a higher priority interrupt occurs during this additional latency period, it is serviced before the original lower priority interrupt, assuming both are enabled.

The effects of multicycle instructions are:

- ❑ **Memory access using wait states.** An instruction that writes to or reads from external memory may be delayed by wait states caused by the external READY pin or the on-chip wait-state generator. These wait states may affect the instruction being executed at the time the interrupt is requested, and they may affect the interrupt itself if the interrupt vector must be fetched from external memory.
- ❑ **Repeat loop.** When repeated with RPT, instructions run parallel operations in the pipeline, and the context of these additional parallel operations cannot be saved in an interrupt service routine. To protect the context of the repeated instruction, the CPU locks out all interrupts except reset until the RPT loop completes.

Note:

Reset (\overline{RS}) is not delayed by multicycle instructions. An NMI can be delayed by multicycle instructions.

If one interrupt is being serviced, there are other factors that delay the servicing of a new interrupt:

- ❑ A return address (incremented program counter value) is forced onto the hardware stack every time the CPU follows another interrupt service routine or other subroutine. The '240 has a feature that helps you keep the hardware stack from overflowing. Interrupts cannot be processed between the CLRC INTM (enable maskable interrupts) instruction and the next instruction in a program sequence. This ensures that a return instruction that directly follows CLRC INTM is executed before an interrupt is processed. The return instruction pops the previous return address off the top of the stack before the new return address is pushed onto the stack. If the interrupt occurs before the return, the new return address is added to the hardware stack, even if the stack is already full.
- ❑ Interrupts are also blocked after an RET instruction until at least one instruction is executed at the return address.

ISR branching time

ISR branching time is the time it takes to execute all the necessary branches to get to the event-specific portion of the ISR. This length of time varies depending on how you have implemented the ISR. For the simplest situation in which only one branch to the ISR is required, the minimum branching time is four DSP cycles. See the section titled *Additional Tasks of ISRs*, for the three different methods of implementing ISRs for maskable interrupts.

2.5.7 External Interrupts

The '240 has five external interrupts. These interrupts include:

- ❑ **XINT1.** The XINT1 control register (at 7070h) provides control and status for this interrupt. XINT1 can be used as a high-priority (Level 1) or low-priority (Level 6) maskable interrupt or as a general-purpose input pin.
- ❑ **NMI.** The NMI control register (at 7072h) provides control and status for this interrupt. NMI is a nonmaskable external interrupt or a general-purpose input pin.
- ❑ **XINT2.** The XINT2 control register (at 7078h) provides control and status for this interrupt. XINT2 can be used as a high-priority (Level 1) or low-priority (Level 6) maskable interrupt or a general-purpose I/O pin.
- ❑ **XINT3.** The XINT3 control register (at 707Ah) provides control and status for this interrupt. XINT3 can be used as a high-priority (Level 1) or low-priority (Level 6) maskable interrupt or as a general-purpose I/O pin.
- ❑ **PDPINT.** This interrupt is provided for safe operation of the power converter and motor drive. This maskable interrupt can put the timers and PWM output pins in high-impedance states and inform the CPU in case of motor drive abnormalities such as overvoltage, overcurrent, and excessive temperature rise. PDPINT is a Level 2 interrupt. Figure 3–5 shows the wake up sequence from a power down.

Table 3–6, *External Interrupt Types and Functions*, on page 3-19 provides a summary of the external interrupt capabilities of the '240.

2.5.8 Peripheral Interrupt Enable Sequence

You must ensure that the interrupts on the 'F/C240 are enabled correctly. You can inadvertently prevent the recognition of interrupts by following an incorrect initialization order.

This situation occurs when the peripheral interrupts are enabled *before* the core IFR, IMR, and INTM are initialized. If this should happen, when an interrupt request is sent to the core IFR and the core IFR is then cleared, the interrupt request is lost.

You can avoid this situation by using the following three-step procedure:

- 1) Set up the core interrupts (assume INTM = 1)
- 2) Enable peripheral interrupts
- 3) Enable interrupts globally (INTM = 0)

The following code shows an example of the recommended sequence:

```
; STEP1 Set up the core interrupts (assume INTM = 1)
    LDP    #0h                ; set data page
    SPLK  #111111b,IFR       ; clear any pending interrupts
    SPLK  #001000b,IMR       ; enable desired interrupts

; STEP2:  Enable peripheral interrupts here ...
EV Capture 1-3 interrupt uses as example
    LDP    #DP_EV            ; set data page
    SPLK  #0ffffh,EVIRC     ; clear all group C interrupt
                             ; flags
    LACL  #0111b            ; bits 1-3 for capture 1 and 2
                             ; and 3
    OR    EVIMRC            ; OR into interrupt mask
                             ; register
    SACL  EVIMRC            ; write back

; STEP3:  Enable global interrupts in core
    CLRC  INTM              ; enable global interrupts
```

After interrupt initialization, code should never manually clear an IFR bit(s) without also reading the EVIVRx or SYSIVR register that is mapped to the IFR bit(s) that are being cleared.

2.5.9 Summary of Interrupt Operation

Once an interrupt has been passed to the CPU, the CPU operates in the following manner (see Figure 2-17, *Interrupt Operation Flowchart*, on page 2-47):

- If a maskable interrupt is requested:
 - 1) The flag bit in the individual control register is set. If the individual mask bit is also set, the corresponding IFR bit is set.
 - 2) Once the IFR bit is set, the acknowledgement conditions (INTM bit = 0 and IMR bit = 1) are tested. If the conditions are true, the CPU services the interrupt, generating an interrupt acknowledge signal; otherwise, it ignores the interrupt and continues with the current code sequence.

- 3) When the interrupt has been acknowledged, the IFR bit is cleared to 0 and the INTM bit is set to 1 (to block other maskable interrupts). The flag bit in the corresponding control register is *not* cleared.
- 4) The return address (incremented PC value) is saved on the stack.
- 5) The CPU branches to and executes the interrupt service routine (ISR). The ISR is concluded by a return instruction, which pops the return address off the stack. The CPU continues with the interrupt code sequence.

If a nonmaskable interrupt is requested:

- 1) The CPU immediately acknowledges the interrupt, generating an interrupt acknowledge signal.

Note:

When an interrupt is requested by an INTR instruction and the corresponding IFR bit is set, the CPU does not clear the bit automatically. If an application requires that the IFR bit be cleared, the bit must be cleared by software.

- 2) If the interrupt was requested by the \overline{RS} pin, the NMI pin, the NMI instruction, or the INTR instruction, the INTM bit is set to 1 to block maskable hardware interrupts. If the interrupt was requested by the TRAP instruction, the INTM bit is *not* set to 1.
- 3) The return address (incremented PC value) is saved on the stack.
- 4) The CPU branches to and executes the ISR. The ISR is concluded by a return instruction, which pops the return address of the stack. The CPU continues with the interrupted code sequence.

2.6 CPU Interrupt Registers

There are two CPU registers for controlling interrupts:

- The interrupt flag register (IFR) contains flag bits that indicate when maskable interrupt requests have reached the CPU on levels INT1 through INT6.
- The interrupt mask register (IMR) contains mask bits that enable or disable each of the interrupt levels (INT1 through INT6).

Interrupt Flag Register (IFR)

The interrupt flag register (IFR), a 16-bit, memory-mapped register at address 0006h in data-memory space, is used to identify and clear pending interrupts. The IFR contains flag bits for all the maskable interrupts.

When a maskable interrupt is requested, the flag bit in the corresponding control register is set to 1. If the mask bit in that same control register is also 1, the interrupt request is sent to the CPU, setting the corresponding flag in the IFR. This indicates that the interrupt is pending, or waiting for, acknowledgement.

You can read the IFR to identify pending interrupts and write to the IFR to clear pending interrupts. To clear a single interrupt, write a 1 to the corresponding IFR bit. All pending interrupts can be cleared by writing the current contents of the IFR back into the IFR. A device reset clears all IFR bits.

The following events also clear an IFR flag:

- The CPU acknowledges the interrupt.
- The '240 is reset.

Notes:

- 1) To clear an IFR bit, you must write a 1 to it, not a 0.
 - 2) When a maskable interrupt is acknowledged, *only* the IFR bit is cleared automatically. The flag bit in the corresponding control register is *not* cleared. If an application requires that the control register flag be cleared, the bit must be cleared by software.
 - 3) When an interrupt is requested by an INTR instruction and the corresponding IFR bit is set, the CPU does not clear the bit automatically. If an application requires that the IFR bit be cleared, the bit must be cleared by software.
-

The IFR is shown in Figure 2–19; descriptions of the bits follow the figure.

Figure 2–19. Interrupt Flag Register (IFR) — Address 0006h

15–6	5	4	3	2	1	0
Reserved	INT6	INT5	INT4	INT3	INT2	INT1
0	R/W–x	R/W1C–x	R/W1C–x	R/W1C–x	R/W1C–x	R/W1C–x

Note: 0 = Always read as zeros, R = Read access, W1C = Write 1 to this bit to clear it, –n = Value after reset, x = Value unchanged by reset

Bits 15–6 **Reserved.** These bits are always read as 0s.

Bit 5 **INT6.** Interrupt 6 flag. This bit is the flag for interrupts connected to interrupt level INT6.

0 = No INT6 interrupt is pending.

1 = At least one INT6 interrupt is pending. Write a 1 to this bit to clear it to 0 and clear the interrupt request.

Bit 4 **INT5.** Interrupt 5 flag. This bit is the flag for interrupts connected to interrupt level INT5.

0 = No INT5 interrupt is pending.

1 = At least one INT5 interrupt is pending. Write a 1 to this bit to clear it to 0 and clear the interrupt request.

Bit 3 **INT4.** Interrupt 4 flag. This bit is the flag for interrupts connected to interrupt level INT4.

0 = No INT4 interrupt is pending.

1 = At least one INT4 interrupt is pending. Write a 1 to this bit to clear it to 0 and clear the interrupt request.

Bit 2 **INT3.** Interrupt 3 flag. This bit is the flag for interrupts connected to interrupt level INT3.

0 = No INT3 interrupt is pending.

1 = At least one INT3 interrupt is pending. Write a 1 to this bit to clear it to 0 and clear the interrupt request.

Bit 1 **INT2.** Interrupt 2 flag. This bit is the flag for interrupts connected to interrupt level INT2.

0 = No INT2 interrupt is pending.

1 = At least one INT2 interrupt is pending. Write a 1 to this bit to clear it to 0 and clear the interrupt request.

- Bit 0** **INT1.** Interrupt 1 flag. This bit is the flag for interrupts connected to interrupt level INT1.
- 0 =No INT1 interrupt is pending.
 - 1 =At least one INT1 interrupt is pending. Write a 1 to this bit to clear it to 0 and clear the interrupt request.

Interrupt Mask Register (IMR)

The IMR is a 16-bit, memory-mapped register located at address 0004h in data memory space. The IMR contains mask bits for all the maskable interrupt levels (INT1–INT6). Neither NMI nor \overline{RS} is included in the IMR; thus, IMR has no effect on these interrupts.

You can read the IMR to identify masked or unmasked interrupt levels, and you can write to the IMR to mask or unmask interrupt levels. To unmask an interrupt level, set its corresponding IMR bit to 1. To mask an interrupt level, set its corresponding IMR bit to 0. When an interrupt is masked, it is not acknowledged, regardless of the value of the INTM bit. When an interrupt is unmasked, it is acknowledged if the corresponding IFR bit is 1 and the INTM bit is 0. The IMR bits are not cleared by reset.

The IMR is shown in Figure 2–20, *Interrupt Mask Register (IMR)* on page 2-67. Bit descriptions follow the figure.

Figure 2–20. Interrupt Mask Register (IMR) — Address 0004h

15–6	5	4	3	2	1	0
Reserved	INT6	INT5	INT4	INT3	INT2	INT1
0	R/W–x	R/W–x	R/W–x	R/W–x	R/W–x	R/W–x

Note: 0 = Always read as zeros, R = Read access, W = Write access, –n = Value after reset, x = value unchanged by reset

Bits 15–6 **Reserved.** These bits are always read as 0s.

Bit 5 **INT6.** Interrupt 6 mask. This bit masks or unmasks interrupt level INT6.

- 0 =Level INT6 is masked.
- 1 =Level INT6 is unmasked.

Bit 4 **INT5.** Interrupt 5 mask. This bit masks or unmasks interrupt level INT5.

- 0 =Level INT5 is masked.
- 1 =Level INT5 is unmasked.

Bit 3 **INT4.** Interrupt 4 mask. This bit masks or unmasks interrupt level INT4.

- 0 =Level INT4 is masked.
- 1 =Level INT4 is unmasked.

Bit 2 **INT3.** Interrupt 3 mask. This bit masks or unmasks interrupt level INT3.

- 0 =Level INT3 is masked.
- 1 =Level INT3 is unmasked.

Bit 1 **INT2.** Interrupt 2 mask. This bit masks or unmasks interrupt level INT2.

- 0 =Level INT2 is masked.
- 1 =Level INT2 is unmasked.

Bit 0 **INT1.** Interrupt 1 mask. This bit masks or unmasks interrupt level INT1.

- 0 =Level INT1 is masked.
- 1 =Level INT1 is unmasked.

2.6.1 External Interrupt Control Registers

The '240 device has four external interrupt pins, including NMI, with software programmable polarity and priority. These pins are programmed using interrupt control registers. A summary of the control registers is shown in Figure 2–21, *External Interrupt Control Registers*.

Figure 2–21. External Interrupt Control Registers

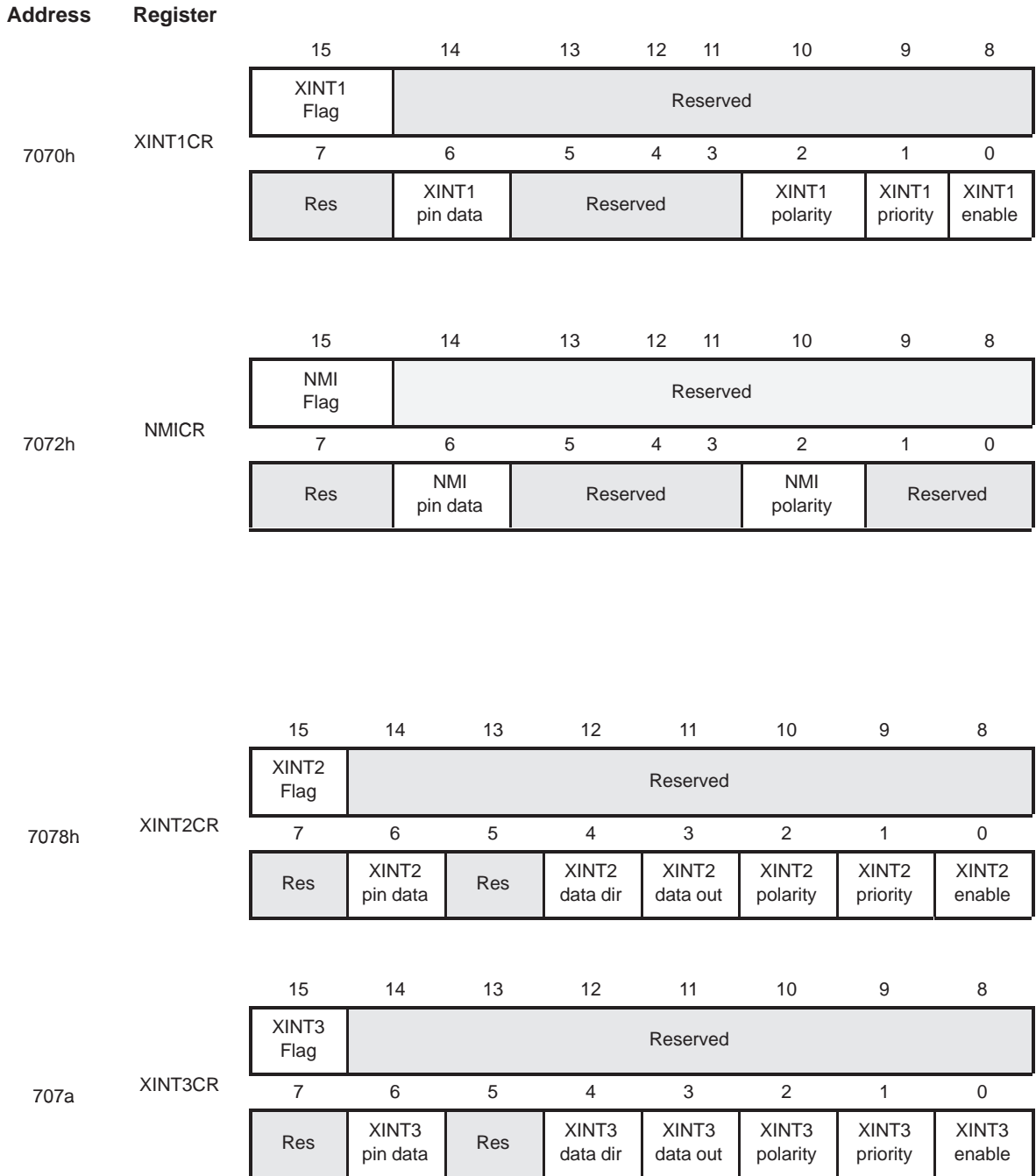

External Interrupt Control Register Bit Descriptions

The NMI, XINT1, XINT2, and XINT3 control registers are shown below together with their bit descriptions.

Figure 2–22. NMI Control Register

15	14–7	6	5	4	3	2	1	0
NMI flag	Reserved	NMI pin data	Reserved			NMI polarity	NMI [riority	NMI enable
R/C–0		R–p				R/W–0	R/W–0	R/W–0

Note: R = Read access, W = Write access, C = Clear-only write access, –n = Value after reset (x means value unchanged by reset), –p = Logic level of pin

Bit 15 **NMI Flag.** Interrupt x flag. This read/clear bit indicates whether the selected transition has been detected on the pin for interrupt x. This bit is set whether or not the interrupt is enabled. You can use this bit for software polling to see if the selected edge has occurred. This bit is cleared by software or a system reset. This bit need not be cleared when this pin is used as an interrupt; the interrupt occurs once for each selected edge on the interrupt pin, even though this bit is already set. Clearing this bit, however, clears a pending request from the pin.

0 = No transition detected
1 = Transition detected

Bits 14–7 **Reserved.** Reads are undefined; writes have no effect.

Bit 6 **NMI Pin data.** Interrupt pin data bit. This read-only bit reflects the current level on the interrupt pin, regardless of how the interrupt pin is configured.

0 = Pin is a logic 0
1 = Pin is a logic 1

Bits 5–3 **Reserved.** Reads are undefined; writes have no effect.

Bit 2 **NMI Polarity.** Interrupt polarity bit. This read/write bit determines whether interrupts are generated on the rising edge or the falling edge of a signal on the pin.

0 = Interrupt generated on a falling edge (high to low transition)
1 = Interrupt generated on a rising edge (low to high transition)

Bit 1 **NMI Priority.** Interrupt priority bit. This read/write bit determines which interrupt priority is requested. This bit has no effect if the NMI bit is set. See the

device data sheet for details about which interrupt level corresponds to high priority and which interrupt level corresponds to low priority.

0 = High priority

1 = Low priority

Bit 0

NMI Enable. Interrupt enable bit. This read/write bit enables or disables the maskable interrupt. This bit has no effect if the NMI bit is set.

0 = Disable interrupt (use pin as digital input)

1 = Enable interrupt

Figure 2–23. XINT1 Control Register (7070h)

15	14–7	6	3–5	2	1	0
INT1 flag	Reserved	INT1 pin data	Reserved	INT1 polarity	INT1 priority	INT1 enable
R/C–0		R–p		R/W–0	R/W–0	R/W–0

Note: R = Read access, W = Write access, C = Clear-only write access, –n = Value after reset (x means value unchanged by reset), –p = Logic level of pin

Bit 15 **XINT1 Flag.** Interrupt x flag. This read/clear bit indicates whether the selected transition has been detected on the pin for interrupt x. This bit is set whether or not the interrupt is enabled. You can use this bit for software polling to see if the selected edge has occurred. This bit is cleared by software or a system reset. This bit need not be cleared when this pin is used as an interrupt; the interrupt occurs once for each selected edge on the interrupt pin, even though this bit is already set. Clearing this bit, however, clears a pending request from the pin.

0 = No transition detected
1 = Transition detected

Bits 14–7 **Reserved.** Reads are undefined; writes have no effect.

Bit 6 **XINT1 Pin data.** Interrupt pin data bit. This read-only bit reflects the current level on the interrupt pin, regardless of how the interrupt pin is configured.

0 = Pin is a logic 0
1 = Pin is a logic 1

0 = Pin is for a regular interrupt or a digital input
1 = Pin is for a nonmaskable interrupt

Bits 5–3 **Reserved.** Reads are undefined; writes have no effect.

Bit 2 **XINT1 Polarity.** Interrupt polarity bit. This read/write bit determines whether interrupts are generated on the rising edge or the falling edge of a signal on the pin.

0 = Interrupt generated on a falling edge (high to low transition)
1 = Interrupt generated on a rising edge (low to high transition)

- Bit 1** **XINT1 Priority.** Interrupt priority bit. This read/write bit determines which interrupt priority is requested. This bit has no effect if the NMI bit is set. See the device data sheet to determine which interrupt levels corresponds to high and low priority.
 - 0 = High priority
 - 1 = Low priority

- Bit 0** **XINT1 Enable.** Interrupt enable bit. This read/write bit enables or disables the maskable interrupt. This bit has no effect if the NMI bit is set.
 - 0 = Disable interrupt (use pin as digital input)
 - 1 = Enable interrupt

Figure 2–24. XINT2 Control Register (7078h)

15	14–7	6	5	4	3	2	1	0
XINT2 flag	Reserved	XINT2 pin data	Reserved	XINT2 fata dir	XINT2 fata out	XINT2 polarity	XINT2 priority	XINT2 enable
R/C–0		R–p		R/W–0	R/W–0	R/W–0	R/W–0	R/W–0

Note: R = Read access, W = Write access, C = Clear-only write access, –n = Value after reset, –p = Logic level of pin

- Bit 15** **XINT2 Flag.** Interrupt flag. This read/clear bit indicates if the selected transition has been detected. This bit is set whether or not the interrupt is enabled. You can use this bit for software polling to see if the selected edge has occurred. This bit can only be cleared by software or a system reset. This bit need not be cleared when this pin is used as an interrupt. The interrupt occurs once for each selected edge on the interrupt pin, even though this bit is already set. Clearing this bit, however, clears a pending request from the pin.
 - 0 = No transition detected
 - 1 = Transition detected

- Bits 14–7** **Reserved.** Reads are undefined; writes have no effect.

- Bit 6** **XINT2 Pin data.** Interrupt pin data bit. This read-only bit reflects the current level on the interrupt pin, regardless of how the interrupt pin is configured.
 - 0 = Pin is a logic 0
 - 1 = Pin is a logic 1

- Bits 5** **Reserved.** Reads are undefined; writes have no effect.
- Bit 4** **XINT2 Data dir.** Interrupt pin data direction bit. When the interrupt pin is not enabled for interrupts, this read/write bit determines whether the pin is a digital input or a digital output.
- 0 = Pin is an input
 - 1 = Pin is an output
- Bit 3** **XINT2 Data out.** Interrupt pin output data bit. This read/write bit determines whether the logic level on the pin is low or high when the pin is used as a digital output pin.
- 0 = Pin level is low (when pin used as digital output)
 - 1 = Pin level is high (when pin used as digital output)
- Bit 2** **XINT2 Polarity.** Interrupt polarity bit. This read/write bit determines whether interrupts are generated on the rising edge or the falling edge of a signal on the pin.
- 0 = Interrupt generated on a falling edge (high to low transition)
 - 1 = Interrupt generated on a rising edge (low to high transition)
- Bit 1** **XINT2 Priority.** Interrupt priority bit. This read/write bit determines which interrupt priority is requested. See the device data sheet for details about which interrupt level corresponds to high priority and which interrupt level corresponds to low priority.
- 0 = High priority
 - 1 = Low priority
- Bit 0** **XINT2 Enable.** Interrupt enable bit. This read/write bit enables or disables the maskable interrupt.
- 0 = Disable interrupt (use pin as digital input or output)
 - 1 = Enable interrupt

Figure 2–25. XINT3 Control Register (707Ah)

15	14–7	6	5	4	3	2	1	0
XINT3 flag	Reserved	XINT3 pin data	Reserved	XINT3 data dir	XINT3 data out	XINT3 polarity	XINT3 priority	XINT3 enable
R/C–0		R–p		R/W–0	R/W–0	R/W–0	R/W–0	R/W–0

Note: R = Read access, W = Write access, C = Clear-only write access, –n = Value after reset, –p = Logic level of pin

Bit 15 **XINT3 Flag.** Interrupt flag. This read/clear bit indicates if the selected transition has been detected. This bit is set whether or not the interrupt is enabled. You can use this bit for software polling to see if the selected edge has occurred. This bit can only be cleared by software or a system reset. This bit need not be cleared when this pin is used as an interrupt. The interrupt occurs once for each selected edge on the interrupt pin, even though this bit is already set. Clearing this bit, however, clears a pending request from the pin.

- 0 = No transition detected
- 1 = Transition detected

Bits 14–7 **Reserved.** Reads are undefined; writes have no effect.

Bit 6 **XINT3 Pin data.** Interrupt pin data bit. This read-only bit reflects the current level on the interrupt pin, regardless of how the interrupt pin is configured.

- 0 = Pin is a logic 0
- 1 = Pin is a logic 1

Bits 5 **Reserved.** Reads are undefined; writes have no effect.

Bit 4 **XINT3 Data dir.** Interrupt pin data direction bit. When the interrupt pin is not enabled for interrupts, this read/write bit determines whether the pin is a digital input or a digital output.

- 0 = Pin is an input
- 1 = Pin is an output

Bit 3 **XINT3 Data out.** Interrupt pin output data bit. This read/write bit determines whether the logic level on the pin is low or high when the pin is used as a digital output pin.

- 0 = Pin level is low (when pin used as digital output)
- 1 = Pin level is high (when pin used as digital output)

Bit 2 **XINT3 Polarity.** Interrupt polarity bit. This read/write bit determines whether interrupts are generated on the rising edge or the falling edge of a signal on the pin.

- 0 = Interrupt generated on a falling edge (high to low transition)
- 1 = Interrupt generated on a rising edge (low to high transition)

- Bit 1** **XINT3 Priority.** Interrupt priority bit. This read/write bit determines which interrupt priority is requested. See the device data sheet for details about which interrupt level corresponds to high priority and which interrupt level corresponds to low priority.
- 0 =High priority
 - 1 =Low priority
- Bit 0** **XINT3 Enable.** Interrupt enable bit. This read/write bit enables or disables the maskable interrupt.
- 0 =Disable interrupt (use pin as digital input or output)
 - 1 =Enable interrupt

System Functions

This chapter describes the device functions that are not specific to any peripheral. They are:

- Peripheral interface.* This interface transfers data between the CPU data bus and the peripheral bus, which is independent of the CPU.
- System configuration registers.* These registers provide software control and status information for functions that affect both the DSP core and certain peripherals.
- Hardware interrupts* (including *reset*). These interrupts require control by both CPU registers and peripheral registers.
- Power-down modes.* These can affect both the CPU and the peripherals.

Topic	Page
3.1 Peripheral Interface	3-2
3.2 System Configuration Registers	3-4
3.3 Power-Down Modes	3-10

3.1 Peripheral Interface

In order to support a large number of peripherals without compromising the electrical performance of the 'C24x DSP CPU's data bus, 'C24x devices have a separate peripheral bus which operates at a lower frequency than the CPU buses. All peripherals, except for the event manager, are attached to this peripheral bus. For improved performance, the event manager interfaces directly to the CPU's data bus.

One of the functions of the peripheral interface is to interface the CPU to the peripheral bus.

The CPU is clocked at either two times ($2 \times$ mode) or four times ($4 \times$ mode) the clock rate of the peripheral bus. Because the peripheral bus runs slower than the CPU bus, peripheral bus reads and writes take multiple CPU cycles. The exact number of CPU cycles a peripheral access takes to complete depends on the:

- Peripheral clock rate
- Phase of the peripheral clock in which the CPU initiates the peripheral access
- Type of access: read or write

Table 3–1, *CPU Cycles to Complete Reads From and Writes to the Peripheral Bus*, on page 3-3 shows how many CPU clock cycles it takes to complete read and write accesses to peripherals connected to the peripheral bus. As an example, if the clocks are in $4 \times$ mode, a single peripheral read may take 5, 6, 7, or 8 CPU cycles, depending on the phase of the peripheral clock when the CPU initiates the peripheral access. If back-to-back accesses are performed, all accesses after the first will take eight cycles in $4 \times$ mode.

Note that writes always take one cycle longer than reads. This is consistent with zero-wait-state external memory accesses and event manager accesses over the CPU's data bus. These accesses take one cycle for a read and two cycles for a write.

Table 3–1. CPU Cycles to Complete Reads From and Writes to the Peripheral Bus

Type of Access	2x Clock Mode		4x Clock Mode	
	Single Accesses (Cycles)	Back-to-Back Accesses (Cycles)	Single Accesses (Cycles)	Back-to-Back Accesses (Cycles)
Read	3 or 4	4	5, 6, 7, or 8	8
Write	4 or 5	4	6, 7, 8, or 9	8

All CPU memory accesses are 16 bits wide. Reads from 8-bit peripherals are LSB aligned. The most significant eight bits of a write to an 8-bit peripheral are ignored. All peripherals are located in the CPU's data space: this allows the full instruction set to act upon the peripheral registers. I/O space is not used by on-chip peripherals.

3.2 System Configuration Registers

The system configuration registers are shown in Figure 3–1 and described in sections 3.2.1 through 3.2.3. The following applies to the register locations:

- ❑ All unimplemented (reserved) bits are read as indeterminate values (unless otherwise stated).
- ❑ Bit 0 of the peripheral address bus is not decoded; therefore, these 16-bit registers are accessible at each even address location and at the (odd) address location that follows. For example, the register SYSIVR is nominally at location 701Eh, but it can also be accessed at address 701Fh.

Figure 3–1. System Configuration Registers

Address	Register																																	
7010h	–	15–0 Reserved																																
7012h	–	15–0 Reserved																																
7014h	–	15–0 Reserved																																
7016h	–	15–0 Reserved																																
7018h	SYSCR	<table border="1"> <tr> <td>15</td> <td>14</td> <td>13–8</td> <td>7</td> <td>6</td> <td>5–0</td> </tr> <tr> <td>RESET1</td> <td>RESET0</td> <td>Reserved</td> <td>CLKSRC1</td> <td>CLKSRC0</td> <td>Reserved</td> </tr> </table>	15	14	13–8	7	6	5–0	RESET1	RESET0	Reserved	CLKSRC1	CLKSRC0	Reserved																				
15	14	13–8	7	6	5–0																													
RESET1	RESET0	Reserved	CLKSRC1	CLKSRC0	Reserved																													
701Ah	SYSSR	<table border="1"> <tr> <td>15</td> <td>14</td> <td>13</td> <td>12</td> <td>11</td> <td>10</td> <td>9</td> <td>8</td> </tr> <tr> <td>PORST</td> <td colspan="2">Reserved</td> <td>ILLADR</td> <td>Reserved</td> <td>SWRST</td> <td>WDRST</td> <td>Reserved</td> </tr> <tr> <td>7</td> <td>6</td> <td>5</td> <td>4</td> <td>3</td> <td>2</td> <td>1</td> <td>0</td> </tr> <tr> <td colspan="2">Reserved</td> <td>HPO</td> <td>Reserved</td> <td>VCCAOR</td> <td colspan="2">Reserved</td> <td>VECRD</td> </tr> </table>	15	14	13	12	11	10	9	8	PORST	Reserved		ILLADR	Reserved	SWRST	WDRST	Reserved	7	6	5	4	3	2	1	0	Reserved		HPO	Reserved	VCCAOR	Reserved		VECRD
15	14	13	12	11	10	9	8																											
PORST	Reserved		ILLADR	Reserved	SWRST	WDRST	Reserved																											
7	6	5	4	3	2	1	0																											
Reserved		HPO	Reserved	VCCAOR	Reserved		VECRD																											
701Ch	–	15–0 Reserved																																
701Eh	SYSIVR	15–0 System interrupt vector register																																

3.2.1 System Control Register (SYSCR)

Figure 3–2. System Control Register (SYSCR) — Address 7018h

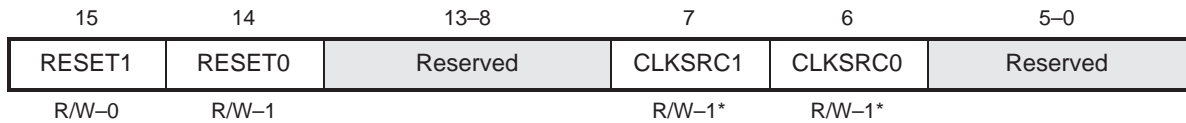

Note: R = Read access, W = Write access, –n = Value after reset,
 * = Not affected by reset, set to 1 by power-on reset

Bits 15–14 RESET1, RESET0. Software reset bits. These bits, which control the software reset function of the device, must be written to at the same time. Writing a 1 to RESET1 or a 0 to RESET0 causes a global reset to occur, as shown in the following table.

RESET1	RESET0	Resulting Action
0	0	Global reset
0	1	–
1	0	Global reset
1	1	Global reset

Bits 13–8 Reserved. Reads are indeterminate; writes have no effect.

Bits 7–6 CLKSRC1, CLKSRC0. CLKOUT-pin source select. These bits control the selection of the CLKOUT pin function.

CLKSRC1	CLKSRC0	CLKOUT Pin Function
0	0	Digital I/O mode (controlled by I/O register bits—see device data sheet).
0	1	WDCLK: Watchdog Timer Clock output mode (nominally 16 kHz).
1	0	SYSCLK: system clock.
1	1	CPUCLK: CPU clock output mode.

Bits 5–0 Reserved. Reads are indeterminate; writes have no effect.

3.2.2 System Status Register (SYSSR)

Bits 15, 12, 10 and 9 of the system status register indicate the cause of a reset. The reset service routine can read this register and use these bits to take the appropriate action according to the cause of reset. For example, if a power-on reset occurs, the clock module control registers may have to be reconfigured.

Figure 3–3. System Status Register (SYSSR) — Address 701Ah

15	14–13	12	11	10	9	8–6	5	4	3	2–1	0
PORST	Res	ILLADR	Res	SWRST	WDRST	Res	HPO	Res	VCCAOR	Res	VECRD
R/C–x		R/C–x		R/C–x	R/C–x		R/C–i		R–1		R–0

Note: R = Read access, C = Clear-only write access, –n = Value after reset (x means value unchanged by reset), –i = Value of V_{CCP} pin latch on rising edge of RESET

Bit 15 **PORST.** Power-on reset status bit.

- 0 = No reset has occurred due to power-on reset signal $\overline{\text{PORESET}}$.
- 1 = Reset due to power-on reset signal $\overline{\text{PORESET}}$.

Bits 14–13 **Reserved.** Reads are indeterminate; writes have no effect.

Bit 12 **ILLADR.** Illegal-address reset status bit. Illegal address reset occurs when an unimplemented on-chip address location in data or program space is accessed. Refer to the '240 memory maps in Chapter 3, *Memory and I/O Spaces*, for details on where these illegal addresses reside.

- 0 = No illegal address conditions
- 1 = Reset due to illegal address

Bit 11 **Reserved.** Reads are indeterminate; writes have no effect.

Bit 10 **SWRST.** Software reset status bit.

- 0 = No software reset
- 1 = Software reset occurred. (A 1 was written to bit 15 of the SYSCR, or a 0 was written to bit 14 of the SYSCR.)

Bit 9 **WDRST.** Watchdog reset status bit.

- 0 = No reset
- 1 = Reset due to Watchdog Timer overflow

Bits 8–6 **Reserved.** Reads are indeterminate; writes have no effect.

- Bit 5** **HPO.** Hardware protect override. If the flash programming voltage pin (V_{CCP}) is at 5V on the trailing edge of the reset pin (\overline{RS}) and is held at that value, the HPO bit is set. (This only applies to an 'F24x device with on-chip flash EEPROM). This value is cleared either by software or when the V_{CCP} pin level changes to 0V.
- 0 = Normal mode
1 = HPO mode: Flash EEPROM programming is enabled and the Watchdog can be disabled by setting the WDDIS bit in the WD control register. For details about this register, see Chapter 13, *Watchdog and Real-Time Interrupt Module*.
- Bit 4** **Reserved.** Reads are indeterminate; writes have no effect.
- Bit 3** **VCCAOR.** Analog V_{CC} (V_{CCA}) out-of-regulation bit. This bit is only valid if the device has an on-chip low-voltage detect module.
- 0 = V_{CCA} is on and in regulation.
1 = V_{CCA} is off or out of regulation.
- Bits 2–1** **Reserved.** Reads are indeterminate; writes have no effect.
- Bit 0** **VECRD.** Interrupt vector read pending bit. This bit is set when an interrupt vector is loaded into the SYSIVR (when the interrupt is acknowledged). It is cleared when the SYSIVR is read. This bit is used by the service routine of non-maskable interrupt NMI (see *Programming an ISR for Nonmaskable Interrupt (NMI)* on page).
- 0 = No read of the interrupt vector register is pending.
1 = An interrupt vector has been latched but has not been read yet.

3.2.3 System Interrupt Vector Register (SYSIVR)

The system interrupt vector register is a read-only register.

Figure 3–4. System Interrupt Vector Register (SYSIVR) — Address 701Eh

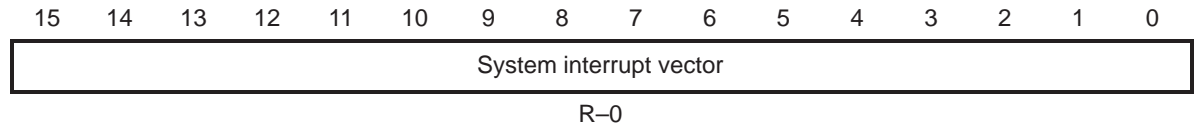

Note: R = Read access, –n = Value after reset

- Bits 15–8** Eight MSBs of the system interrupt vector. These bits are always read as 0s.
- Bits 7–0** Eight LSBs of the system interrupt vector. These bits are loaded with the interrupt vector address offset value. This value is generated by a peripheral attached to the peripheral bus in response to the acknowledgement of the corresponding maskable interrupt.

The SYSIVR is a read-only register intended to provide a peripheral interrupt vector address. While executing code from flash memory, SYSIVR can be read only once during vector fetch. Successive reads will stall the instruction fetch and will stop the CPU indefinitely. However, this problem does not occur if two reads are separated by a NOP instruction.

3.3 Power -Down Modes

A '240 device can have up to four power-down modes that reduce the operating power of the '240 device by stopping the clocks (and, thus, the activity and power consumption) of the CPU and various on-chip peripherals. While the '240 is in a power-down mode, all of its internal contents are maintained and operation continues unaltered when the power-down mode is terminated with an interrupt. The content of all on-chip RAM remains unchanged. However, if the power-down mode is terminated with a reset, the contents of some registers are changed. These are the register contents that are always changed during a reset.

3.3.1 Clock Generation

The TMS320x240 has an on-chip, PLL-based clock module. This module provides all necessary clocking signals for the device as well as control for low-power mode entry. The only external component necessary for this module is an external fundamental reference crystal.

The '240 has two basic clocking domains: the CPU clock domain (CPUCLK), and the system clock domain (SYSCLK). The CPU, memories, external memory interface, and event manager are located in the CPU clock domain. All other peripherals are in the system clock domain. The CPUCLK runs at $2 \times$ or $4 \times$ the frequency of the SYSCLK; that is, CPUCLK = 20 MHz, SYSCLK = 10 MHz, or CPUCLK = 20 MHz, SYSCLK = 5 MHz.

There are three different clock domains that can be shut off during power down:

- CPU clock domain.** All clocks in the CPU and memories except the interrupt control registers
- System clock domain.** All peripheral clocks (CPUCLK or SYSCLK), and the clocks for the CPU's interrupt control registers
- Watchdog clock (WDCLK).** The nominally 16 kHz clock used to increment the watchdog timer and real time Interrupt module

Note:

The terms CPUCLK and CPU clock domain, SYSCLK and system clock domain are *not* interchangeable.

The four types of possible power-down modes on a '240 device have decreasing levels of power consumption and increasing delays to exit the low power mode. All of the possible power-down modes may not be implemented on a '240 device. A low-power mode is entered when the CPU executes an IDLE instruction. The PLLPM(1:0) bits in the CKCR0 register in the clock module determine which of the four possible low power modes is entered.

The power-down modes, in order of decreasing power and increasing startup time, are as follows:

- ❑ **Idle1** mode stops the clocks to the CPU (CPU clock domain) but the clocks for all peripherals (system clock domain) continue to run. Exit from Idle1 occurs immediately following any interrupt or a reset.
- ❑ **Idle2** mode stops the clocks in both the CPU clock domain and the system clock domain. Exit from Idle2 occurs immediately following a wakeup interrupt or a reset. The watchdog clock continues to run, eventually times out, and causes a reset.
- ❑ **PLL power-down** mode powers down the PLL (if enabled). The watchdog clock continues to run. Exit from this mode can be caused by a wakeup interrupt or a reset. The watchdog clock continues to run, eventually times out, and causes a reset. The device does not start full-speed operation until the PLL has powered up and reattained lock, which can be hundreds of microseconds.
- ❑ **Oscillator power-down** mode shuts off power to the oscillator (if enabled) and is the lowest power mode available. No clocks are running on the device. A wakeup interrupt or reset causes the device to exit this low-power mode. No clock runs until the oscillator has powered back up; the power-up time is in milliseconds. The device does not start full-speed operation until the PLL has powered up and reattained lock (this can be additional hundreds of microseconds).

For details of the low-power mode power consumption for each device, see the relevant device data sheet. Table 3–2, *Power-Down Modes*, shows the status of the CPU and peripheral clocks during each of the four power-down modes.

Table 3–2. Power-Down Modes

Mode	CPU Clock Domain	System Clock Domain	Watchdog Clock	Oscillator
Idle1	Off	On	On	On
Idle2	Off	Off	On	On
PLL power down	Off	Off	On	On
Oscillator power down	Off	Off	Off	Off

3.3.2 Setting and Entering the Power-Down Modes

The power-down modes are initiated by the execution of the IDLE instruction. The value in the PLLPM field of clock module control register 0 (CKCR0) determines the mode. Table 3–3, *Setting the Power-Down Mode With the PLLPM bits*, shows how the two PLLPM bits of CKCR0 determine the power-down mode.

Table 3–3. Setting the Power-Down Mode With the PLLPM Bits

PLLPM bits	Power-Down Mode
00	Idle1
01	Idle2
10	PLL power down
11	Oscillator power down

3.3.3 Exiting the Power-Down Modes

In any one of the four power-down modes (Idle1, Idle2, PLL power down, and oscillator power down), the CPU clock domain is off. Therefore, software interrupts cannot be generated to take the processor out of power-down. Interrupts can only be generated at external pins or by on-chip peripherals.

Reset. Reset signals terminate power-down modes as follows:

- The reset pin (\overline{RS}) causes the device to exit *any* power-down mode.
- Watchdog timeout reset causes the device to exit Idle1, Idle2, or PLL power down. The watchdog timer is not incrementing during oscillator power down because the watchdog clock is stopped.

External interrupts. All power-down modes terminate when the CPU receives any one of these interrupts at a pin:

- NMI
- XINTn (any external interrupt controlled by the external interrupt control registers, if unmasked).

Wakeup interrupts. The external interrupts XINTn and NMI are also wakeup interrupts. After the clocks are shut off, a combinatorial logic path from these pins restarts the clocks.

The external interrupts, XINTn, are maskable interrupts and can completely bring the processor out of the power-down mode only if they are unmasked. If they are masked, they wake up the device by starting all clocks; however, the device remains in the IDLE state.

Certain peripherals are also able to generate wakeup interrupts when the clocks in the system clock domain are shut off. For example, some communication ports may be able to generate a wakeup interrupt in response to receiving a character.

Oscillator power down mode is only terminated by an external interrupt (NMI or XINTn). In this mode, the oscillator is off (no clocks on the device are active); thus, no interrupts can be generated by on-chip peripherals, and the watchdog timer cannot generate a time-out signal.

Peripheral interrupts. The Idle1, Idle2, and PLL power-down modes can be terminated by various peripheral interrupts under the right conditions. In Idle1 mode, all the clocks for the peripheral devices are still running; therefore, any unmasked peripheral interrupt terminates the Idle1 mode. In the Idle2 and PLL power-down modes, the clocks in the system clock domain are off. As a result, only unmasked peripheral interrupts that are not timed by the system clock can bring the processor out of the Idle2 and PLL power-down modes.

In oscillator power-down mode, the peripheral clocks and the Watchdog timer clocks are off. Only unmasked peripheral interrupts not timed by either of those clocks can terminate oscillator power-down mode.

Table 3–5, *Power-Down Modes and Their Terminations*, on page 3-15 summarizes the state of processors in each power-down mode and lists the interrupts that do and do not terminate each mode.

3.3.4 Low-Power Mode

The '240 device has four low-power modes (Idle1, Idle2, Standby, and Halt). Low-power modes reduce the operating power by reducing or stopping the activity of various modules (by stopping their clocks). The two PLLPM bits of the clock-module-control register (CKCR0) select which of the low-power modes the device enters when executing an IDLE instruction. Reset, or an unmasked interrupt from any source, causes the device to exit from idle 1 low-power mode. A real-time interrupt (from WD/RTI) causes the device to exit all except the halt low-power mode (idle 1, idle 2, and standby). This is a wake-up interrupt.

Reset, or any of the four external interrupts (NMI, XINT1, XINT2, or XINT3, if enabled), causes the device to exit from any low-power mode (Idle1, Idle2, Standby, and Halt). The external interrupts are all wake-up interrupts. Any interrupt designed to allow an exit from a low-power mode must be enabled individually and globally to bring the device out of a low-power mode properly. It is important to ensure that the desired low-power mode exit path is enabled before entering a low-power mode.

Table 3–4 lists the low-power modes.

Table 3–4. Low Power Modes

Low-Power Mode	PLLPM(1:0) Bits in CKCR0	CPU Clock Status	System Clock Status	PLL Status	Watchdog Clock Status	Oscillator Clock	Exit Condition	Description
X + not IDLE	XX	On	On	On	On	On	—	Run
0 + IDLE	00	Off	On	On	On	On	Any interrupt, reset	Idle1
1 + IDLE	01	Off	Off	On	On	On	Wake-up interrupt, reset	Idle2
2 + IDLE	10	Off	Off	Off	Off	On	Wake-up interrupt, reset	Standby
3 + IDLE	11	Off	Off	Off	Off	Off	Wake-up interrupt, reset	Halt

Table 3–5. Power-Down Modes and Their Terminations

Mode	CPU Clock Domain	System Clock Domain	PLL	Watchdog Clock	Oscillator	Terminated By	Not Terminated By
Idle1	Off	On	On	On	On	Reset (\overline{RS}) Watchdog reset NMI (at pin) XINT's (at pin, unmasked) Any peripheral interrupt (unmasked)	Masked interrupts
Idle2	Off	Off	On	On	On	Reset (\overline{RS}) Watchdog reset NMI (at pin) XINT's (at pin, unmasked) Peripheral wakeup interrupts.	Masked interrupts Peripheral interrupts dependent on the system clock.
PLL power down (PPD)	Off	Off	Off	Off	On	Reset (\overline{RS}) Watchdog reset NMI (at pin) XINT's (at pin, unmasked) Peripheral wakeup interrupts	Masked interrupts Peripheral interrupts dependent on the system clock
Oscillator power down (OPD)	Off	Off	Off	Off	Off	Reset (\overline{RS}) NMI (at pin) XINT's (at pin, unmasked) Peripheral wakeup interrupts	Masked interrupts Peripheral interrupts

3.3.5 After Exiting Power-Down

There are two items to consider when deciding how to wake the processor:

- If you use reset or NMI, the CPU immediately executes the corresponding interrupt service routine.
- If you use a maskable hardware interrupt, the next action depends on the interrupt mode (INTM) bit of status register ST0:
 - **INTM = 0:** The interrupt is enabled, and the CPU executes the corresponding interrupt service routine.
 - **INTM = 1:** The interrupt is disabled, and the CPU continues with the instruction after IDLE.

If you do not want the CPU to execute an interrupt service routine before continuing with the interrupted program sequence:

- Do not use reset or NMI to bring the processor out of power-down.
- Make sure your program sets INTM to 1 (SETC INTM) before IDLE is executed.

If you want the CPU to execute the interrupt service routine before continuing:

- Make sure your program clears INTM to 0 (CLRC INTM) before IDLE is executed.
- Make sure you enable all relevant interrupt sources, both locally (in the peripheral mask/enable registers) and globally (in the CPU's interrupt mask register).

Figure 3–5. Waking Up the Device from Power Down

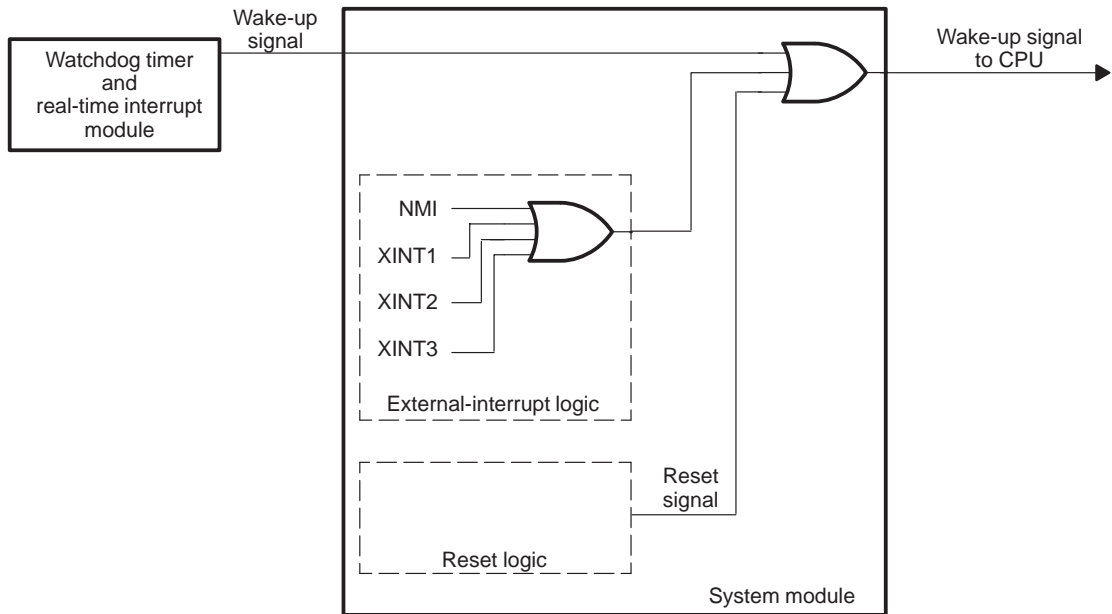

3.3.6 Summary of Power-Down Mode Operation

When the IDLE instruction is executed:

- 1) The program counter is incremented once, so that when the power-down mode is exited, the next instruction is the one that follows the IDLE instruction, except in the case of reset.
- 2) The '240 enters the power-down mode selected by the PLLPM bits and remains in that low-power state until it receives a proper hardware interrupt (as described in section 3.3.3, *Exiting the Power-Down Modes*, on page 3-12).
- 3) Upon receipt of the proper interrupt, the '240 exits the power-down mode.
- 4) If you use NMI to wake the processor, the CPU executes the corresponding interrupt service routine before continuing with the interrupted program sequence.

If you use a maskable interrupt, the next action depends on the value of the INTM bit:

- INTM = 0:** Maskable interrupts are enabled; the CPU first executes the interrupt service routine of the interrupt that brought it out of power-down. Then it continues with the instruction after the IDLE instruction.
- INTM = 1:** Maskable interrupts are disabled; the CPU continues execution of the instruction after IDLE.

Table 3–2, *Power-Down Modes*, on page 3-12 summarizes the four power-down modes, and provides the approximate power level for each. (For more accurate power values, see the data sheet for your particular 'C24x device.) In addition, the table shows the status of the '240 when not in a power-down mode. See Table 3–5, *Power-Down Modes and Their Terminations*, on page 3-15 for the list of interrupts that do and do not terminate each mode.

Table 3–6. External Interrupt Types and Functions

External Interrupt	Control Register Address	Interrupt Type	Can Do NMI?	Digital I/O Pin	Maskable?
XINT1	7070h	A	No	Input only	Yes (Level 1 or 6)
NMI	7072h	A	Yes	Input only	No
N/C	7074h	B		Reserved	
N/C	7076h	B		Reserved	
XINT2	7078h	C	No	I/O	Yes (Level 1 or 6)
XINT3	707Ah	C	No	I/O	Yes (Level 1 or 6)
N/C	707Ch	PM		Reserved	
N/C	707Eh	PM		Reserved	
PDPINT	742Ch	N/A	N/A	N/A	Yes (Level 2)

PLL Clock Module

This chapter describes the architecture, functions, and programming of the PLL clock module. The PLL clock module provides all necessary clock signals for 'C24x devices.

Note: 8-Bit Peripheral

This module is interfaced to the 16-bit peripheral bus as an 8-bit peripheral. Therefore, reads from bits 15–8 are undefined; writes to bits 15–8 have no effect.

Topic	Page
4.1 PLL Clock Module Overview	4-2
4.2 PLL Clock Operation	4-5
4.3 PLL Clock Control Registers	4-14

4.1 PLL Clock Module Overview

The PLL clock module interfaces to the peripheral bus and provides all of the clocks required for the entire device (see Figure 4–1). There are four sets of clocks, all running at different frequencies:

- ❑ **CPUCLK** – This is the highest frequency clock provided by the module and is used by the CPU, all memories and any peripherals tied directly to the CPU buses, including an external memory interface if used. All other clocks are derived by dividing this clock down to a lower frequency.
- ❑ **SYSCLK** – This clock is a half or a quarter the rate of CPUCLK. It is used to clock all the peripherals on the TI peripheral bus.
- ❑ **WDCLK** – This is the low power clock used by the watchdog timer/real-time interrupt module. It has a nominal frequency of 16 kHz with a 25% duty cycle.

The clock module operates with a 4, 6, or 8 MHz reference crystal in conjunction with its on-chip oscillator circuit, or an external oscillator bypass clock in the range 2–20 MHz. The PLL can multiply the input frequency by factors of 1, 2, 3, 4, 5, and 9. The input clock can also be divided by two before this multiplication to give additional factors of 1.5, 2.5, and 4.5. The actual CPU clock frequency is software selectable from 2 MHz up to the maximum operating frequency of the device. The PLL can also be bypassed with a $1\times$ or $2\times$ (CPUCLK frequency) clock-in input.

Note:

If clock-in has a higher frequency than 20 MHz, the WDCLK frequencies will not be correct.

The clock module contains all necessary control registers. It also contains low-power mode control bits that determine which clocks are switched off when the CPU goes into idle mode.

Figure 4–1. PLL Clock Module Block Diagram

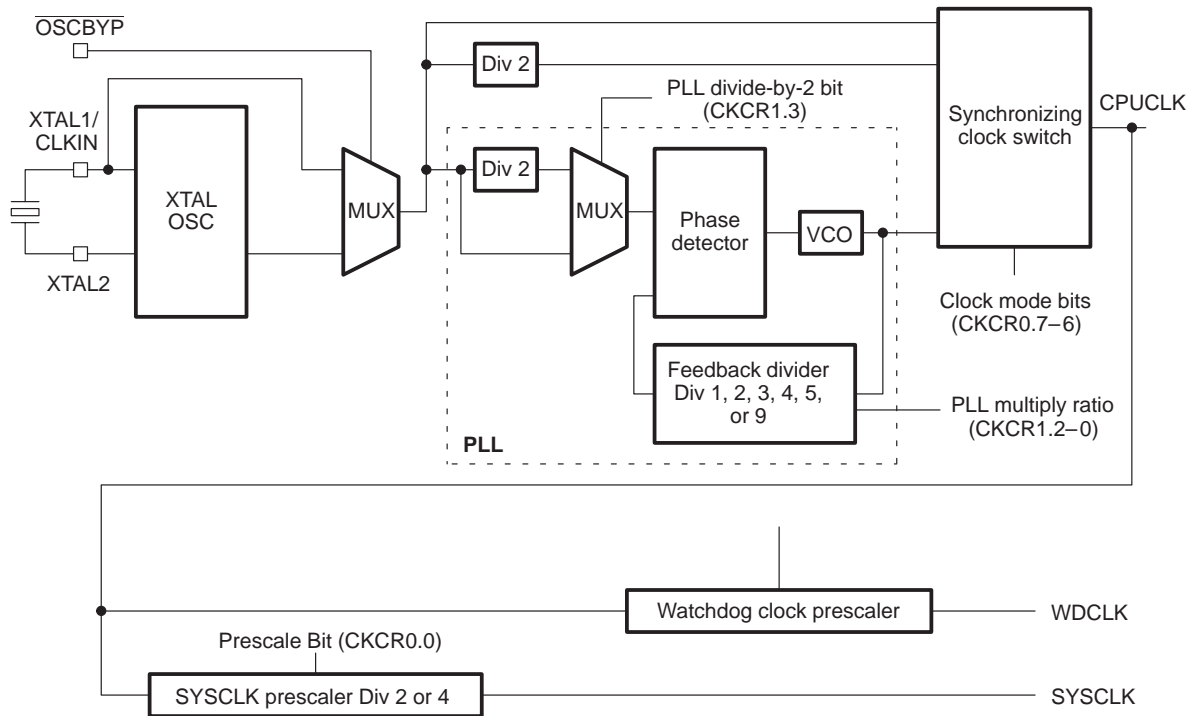

Two registers (listed in Table 4–1) control the PLL Clock Module operations:

CKCR0 (Clock control register 0)

This register contains bits used for general control of the clock module, such as clock mode, low-power mode selection, SYSCLK prescale selection, and status flags.

CKCR1 (Clock control register 1)

This register specifies the PLL multiplication factor (if enabled) and the frequency of the input clock.

Table 4–1. Addresses of PLL Clock Module Control Registers

Address	Register	Name	Described in	
			Section	Page
7020h		Reserved†		
7022h		Reserved†		
7024h		Reserved†		
7026h		Reserved†		
7028h		Reserved†		
702Ah‡	CKCR0	Clock Control Register 0	4.3.1	4-14
702Ch‡	CKCR1	Clock Control Register 1	4.3.2	4-16
702Eh		Reserved		

† Reserved for the watchdog and real-time interrupt module control registers. See Chapter 5, *Watchdog (WD) and Real-Time Interrupt (RTI) Module*.

‡ Each register also appears at the next odd address location; ex. CKCR0 appears at 702Bh and CKCR1 appears at 702Dh.

4.2 PLL Clock Operation

This section describes the operation and functionality of the PLL clock module. Included are these topics:

- Pin description
- Oscillator operation modes
- PLL operation modes
- CPU clock (CPUCLK) signal frequency selection
- System clock (SYSCLK) signal prescale selection
- Watchdog counter clock (WDCLK) signal
- PLL startup
- Low-power modes

4.2.1 Pin Description

The PLL module has three associated pins:

$\overline{\text{OSCBYP}}$

The oscillator bypass ($\overline{\text{OSCBYP}}$) pin is used to select whether the oscillator is bypassed or not. If the device is used with an external clock input (that is, not used with a reference crystal), this signal should be tied to 0V to bypass the crystal reference oscillator circuit.

XTAL1/CLKIN

The oscillator in (XTAL1/CLKIN) pin is typically tied to one side of a 4, 6, or 8 MHz-reference crystal. This pin may also be used as a clock in pin for an external signal. See section 4.2.2, *Oscillator Operation Modes*, for details.

XTAL2

The oscillator out (XTAL2) pin is:

- Tied to the other side of a 4, 6, or 8 MHz reference crystal, or
- Left open when an external clock is provided via XTAL1/CLKIN.

4.2.2 Oscillator Operation Modes

The oscillator has two operation modes: oscillator and oscillator bypass (clock-in) modes (see Table 4–2):

Oscillator mode

This is the normal operation mode when you use an external reference crystal. This mode is entered when the $\overline{\text{OSCBYP}}$ pin is tied high (V_{IH}) and a 4, 6, or 8 MHz crystal is connected between XTAL1 and XTAL2 to provide a reference crystal frequency. Following device power up it takes about 1 ms for the crystal oscillator circuitry to power up and start generating a good clock.

Clock-in mode

You can bypass the oscillator circuitry by tying the $\overline{\text{OSCBYP}}$ pin low (V_{IL}). This allows the device to be clocked by an external signal input on the XTAL1/CLKIN pin. The oscillator circuitry is powered down when bypassed.

Table 4–2. Oscillator Operation Mode Selection

$\overline{\text{OSCBYP}}$ Pin Levels	Oscillator Operation Mode
V_{IH}	Oscillator mode
V_{IL}	Oscillator bypass (Clock In) mode

4.2.3 PLL Operation Modes

The clock module can operate with the PLL as the clock source or with a divide-by-1 or a divide-by-2 bypass clock.

The CLKMD(1:0) (CKCR0.7–6) bits set the clock source as follows:

CLKMD(1:0)	Mode
00	CLKIN / 2
01	CLKIN
10	PLL
11	PLL

The PLL is only powered up when enabled, CLKMD(1) = 1.

This PLL has a counter to ensure that enough time has elapsed for the PLL to lock at all frequencies before the device is switched over to run from PLL clocks. This lock counter is cleared by a power-on-reset. The PLLLOCK(1) bit in CKCR0 indicates that the PLL counter has rolled over, the PLL has locked and the device is running on PLL clocks.

PLL multiplication factor can be set to multiply by 1, 2, 3, 4, 5, and 9. It is controlled by the PLLFB(2:0) bits in CKCR1. Additionally, the clock input to the PLL can be divide-by-2 before use to give additional multiplication factors of 1.5, 2.5, and 4.5. This is controlled by the PLLDIV2 bit in CKCR1.

4.2.4 CPU Clock (CPUCLK) Frequency Selection

The PLL clock module gives you the option of generating one of many possible software-selectable CPU clock (CPUCLK) frequencies for a given crystal or clock in frequency. The selection of the actual CPUCLK frequency is controlled by four bits in the CKCR1 control register:

- The PLL multiplication ratio select bits, PLLFB(2:0) (CKCR1.2–0). These bits control the PLL multiplication factor.
- The PLL input divide-by-2 control bit, PLLDIV2 (CKCR1.3). This bit controls whether or not the clock input to the PLL is divided by 2.

The following formulas may be used to calculate the CPU clock frequency given the crystal frequency and the register values:

$$f_{\text{CPUCLK}} = f_{\text{CKIN}} * (\text{PLL Multiply Ratio}) / 2^{\text{PLLDIV2}}$$

where,

$$0 \text{ MHz} < f_{\text{CPUCLK}} < 20 \text{ MHz}$$

Table 4–3 shows all possible locked CPU clock frequencies, with 10 different crystal or clock-in frequencies, by using different settings of the feedback bits.

CAUTION:

x240 devices are designed to run at 20 MHz CPUCLK. While selecting PLL register values, care should be taken to limit the CPUCLK rate to 20 MHz maximum.

Table 4–3. Selectable CPU Clock Frequencies in MHz

Crystal or Clock-In Frequency (MHz)	PLL Multiply Ratio * 2 ^{PLLDIV2}								
	1	1.5	2	2.5	3	4	4.5	5	9
2	2	3	4	5	6	8	9	10	18
4	4	6	8	10	12	16	18	20	
6	6	9	12	15	18				
8	8	12	16	20					
10	10	15	20						
12	12	18							
14	14								
16	16								
18	18								
20	20								

4.2.5 System Clock (SYSCLK) Frequency Selection

The system clock (SYSCLK) frequency is generated by dividing the CPUCLK by 2 or by 4. The SYSCLK divider is controlled by the prescale select bit, PLLPS (CKCR0.0). This bit controls two possible prescale options, as described in Table 4–4.

Table 4–4. PLL Prescale Selection Options

PLLPS (CKCR0.0)	SYSCLK Prescale Selection Options
0	CPUCLK divided by 4
1	CPUCLK divided by 2

4.2.6 Watchdog Counter Clock (WDCLK)

The PLL clock module provides a watchdog counter clock (WDCLK) signal to the WD/RTI (if available on the device). The WDCLK is generated by dividing CPUCLK to yield a WDCLK signal of about 16384 Hz. WDCLK is produced by a divider circuit which is controlled by the contents of the PLLFB(2:0), PLLDIV2, CKINF(3:0), CLKMD(1:0), and PLLOCK(1) bits. If the CKINF(3:0) bits are not programmed correctly, the WDCLK frequency will be incorrect.

Note that WDCLK is only 16 384 Hz (2^{14} Hz) when CLKIN is a power of 2 Hz, see Table 4–5.

Table 4–5. Watchdog Counter Clock Frequencies

CLKIN (Hz)	WDCLK (Hz)
4 000 000	15 625
4 194 304 (2^{22})	16 384
8 000 000	15 625
8 388 608 (2^{23})	16 384

A good way to obtain a higher or lower WDCLK frequency is to put an incorrect value in the CKINF bits. For example, if CLKIN = 4.194304 MHz, but CKINF is set to 1111 (2 MHz), WDCLK will be 32.768 kHz.

4.2.7 PLL Startup

When the device first powers up the PLL is neither selected nor powered, the device is running off the oscillator (or oscillator bypass) clocks divided-by-2 (CLKMD = 00). The CLKMD(1:0) bits are cleared to 0 by Power-On Reset, as are the PLLFB(2:0) and PLLDIV2 bits.

If PLL clocks are required the PLLFB(2:0) and PLLDIV2 bits should be set to the desired values and the CLKMD(1) bit set to 1. The PLL is powered up and starts to lock. This takes about 100 μ s. The device continues to run off the divide-by-2 (or 1) clocks until the PLL lock counter has rolled over, indicating that the PLL has reached lock with its new settings. At this time, the clock module automatically does a glitch-free switch over to the PLL clocks. If the user needs to prevent some code from being executed before the switch to the (higher frequency) PLL clocks has occurred, the PLLOCK(1) bit in CKCR0 can be polled. This bit indicates that the PLL has locked and the device is now running on PLL clocks.

Subsequent changes to the PLLFB and DIV2 bits do not have an immediate effect on the PLL if it is selected as the clock source. If these bits are changed, the changes do not start to take effect until the PLL is deselected by clearing the CLKMD(1) bit. The CLKMD(1) bit should then be immediately set back to 1, the PLL will be powered back up and will start to lock with the new settings. The device will continue to run on the oscillator clocks. When the PLL rellocks, the device switches back to PLL clocks.

4.2.8 Low-Power Modes

When the IDLE instruction is executed, power is saved by shutting off some or all of the on-chip clocks sources. For the purposes of low power modes, there are three different clock domains that can be shut down independently:

- CPU Clock Domain.** All clocks in CPU memory except for the interrupt registers.
- System Clock Domain.** All peripheral clocks (CPUCLK or SYSCLK) and the clocks for the CPU's interrupt register.
- Watch Dog Clock.** The nominally 16 kHz clock used to increment the Watch Dog Timer (WDCLK).

Note:

The terms CPUCLK and CPU clock domain, SYSCLK and system clock domain are not interchangeable.

Executing the IDLE instruction causes the device to enter one of the four low-power modes. The low-power mode that the device enters depends on the PLLPM(1:0) (CKCR0.3–2) bits. The selection bits are summarized in Table 4–6.

Table 4–6. Low-Power Modes

Low Power Mode	PLLPM(1:0) bits	CPU Clock Domain	System Clock Domain	WDCLK	PLL State†	Osc. State†	Exit Condition	Description
X + not IDLE	XX	On	On	On	On	On	—	Normal run mode
0 + IDLE LPM0 (IDLE1)	00	Off	On	On	On	On	Interrupt, reset	Idle1
1 + IDLE LPM1 (IDLE2)	01	Off	Off	On	On	On	Wake-up interrupt, reset	Idle2
2 + IDLE LPM2 (PLL Power Down)	10	Off	Off	On	Off	On	Wake-up interrupt, reset	PLL power down
3 + IDLE LPM3 (Oscillator Power Down)	11	Off	Off	Off	Off	Off	Wake-up interrupt, reset	Oscillator power down

† If enabled

The low-power mode may be exited by a reset or any individually and globally enabled wake-up interrupt. The actual wake-up interrupts available are device-specific, but usually include the real time interrupt (RTI) and the external interrupts (XINTn). See the specific device data sheet to determine the available wake-up interrupts on the device being used.

If the PLL is selected when exiting LPM2 or LPM3, this delays the start of the clocks up to 100 μ s while the PLL locks. In addition, when exiting LPM3 with the oscillator connected to a crystal, there is a delay of about 1ms while the oscillator powers up. If the oscillator is bypassed, there is no delay.

When entering LPM3, WDCLK shuts down synchronously. There may be a delay while the device waits for WDCLK to enter its internal master phase before the CPU clock domains and system clock domains shut down.

LPM2 stops the clocks to all modules, except in WDCLK. This means that the WD counter is active in LPM2. Since the CPU is not active, the WD is not serviced and effectively brings the device out of LPM2 with a WD reset when a WD overflow occurs. If the RTI is enabled, the RTI interrupts the CPU with

a wake-up interrupt, causing the device to exit standby mode. At this time, the WD could be serviced to prevent the device from being reset.

The LPM3 mode stops all internal clock signals and powers down the PLL and the oscillator. This stops all modules, including the WD/RTI, resulting in the lowest power consumption possible.

Note:

Do not enter LPM2 if the PLL is not enabled.

LPMODE 0 Entry/Exit Sequence.

When entering this mode:

- 1) The CPU clock domain is shut down immediately.
- 2) All other chip clocks continue running.

When exiting this mode with an interrupt or reset:

- 1) The CPU clock domain starts running again immediately.

LPMODE 1 Entry/Exit Sequence.

When entering this mode:

- 1) The CPU clock domain is shut down immediately.
- 2) Wait until the system clock domain is in a HIGH state and then stop in that state.
- 3) WDCLK continues to run.

When exiting this mode with a wake-up interrupt or reset:

- 1) The clock module internal clocks start running immediately.
- 2) A few cycles later, the CPU clock domain and the system clock domain start running again.

LPMODE 2 Entry/Exit Sequence.

When entering this mode:

- 1) The CPU clock domain is shut down immediately.
- 2) Wait until the system clock domain is in a HIGH state and then stop in that state.

- 3) WDCLK continues to run.
- 4) Clocks to switch from PLL to by 1 or by 2 mode.
- 5) PLL is powered down.

When exiting this mode with a wake-up interrupt or reset:

- 1) The PLL is powered up and the lock counter begins counting. Clock module internal clocks start running in by 1 or by 2 mode.
- 2) The CPU clock domain and the system clock domain start running again.
- 3) When PLL has locked (lock counter rolled over), the clocks automatically switch back to the PLL.

LPMODE 3 Entry/Exit Sequence.

When entering this mode:

- 1) The CPU clock domain is shut down immediately.
- 2) Wait until the system clock domain is in a HIGH state and then stop in that state.
- 3) WDCLK continues to run.
- 4) Clocks to switch from PLL to by 1 or by 2 mode.
- 5) PLL is powered down.
- 6) WDCLK keeps running until the internal WDCLK mater phase is LOW.
- 7) Clock switching logic goes to *all off* state — that is, all internal clocks are stopped.
- 8) Oscillator (if used) is powered down.

When exiting this mode with a wake-up interrupt or reset:

- 1) The oscillator is re-enabled but the oscillator output is not good for about 1 ms.
- 2) Clock-switching logic switches to by-1 or by-2 state, depending on value of CKMD(0) bit.
- 3) The PLL is powered up and begins to lock.
- 4) The CPU clock domain and the system clock domain start running again.
- 5) When PLL has locked, clocks automatically switch back to the PLL.

4.3 PLL Clock Control Registers

The PLL clock module is controlled and accessed through control registers. These registers are illustrated and described in the following sections.

The address shown for each register is the typical address used for these modules where the offset is 7020h. A different offset may be used on some devices. See the device data sheet for details.

4.3.1 Clock Control Register 0 (CKCR0)

Figure 4–2. Clock Control Register 0 (CKCR0) — Address 702Bh

7	6	5	4	3	2	1	0
CLKMD(1)	CLKMD(0)	PLLOCK(1)	PLLOCK(0)	PLLPM(1)	PLLPM(0)	Reserved	PLLPS
RW-x	RW-x	R-x	R-x	RW-0	RW-0		RW-0

Note: R = read access; W = write access; -x = not affected by system reset, cleared to 0 by power on reset

Bits 7–6 CLKMD(1), CLKMD(0). Read/write bits. These bits select the operational mode of the clock module (Table 4–7).

Table 4–7. CLKMD(1:0) Bits vs. Clock Mode

CLKMD(1:0)	Mode
00	CLKIN / 2
01	CLKIN
10	PLL Enabled
11	PLL Enabled

If the device enters a low-power mode that shuts down the PLL, on exiting that low power mode the device will run on CLKIN/2 until the PLL locks if CLKMD = 10, or it will run on CLKIN if CLKMD = 11.

Bits 5–4 PLLOCK(1), PLLOCK(0). Read only bits. These bits indicate when the PLL has entered the mode selected by the CLKMD(1:0) bits. Bit 0 is really only required for device test. Bit 1 can be used to determine if the PLL is locked. This bit can be software polled after the PLL is enabled to prevent the execution of any time critical code prior to the module switching over to PLL clocks. This bit is unaffected by a system reset and is cleared to 0 by a power-on reset.

- 0 = PLL not locked — running off Clock In
- 1 = PLL locked and running off PLL clocks

Bits 3–2 **PLLPM(1), PLLPM(0).** Read/write bits. These bits specify which low power mode will be entered upon execution of an IDLE instruction. These bits are cleared (00b) during power-on and system reset, making LPM0 the default. See section 4.2.8, *Low-Power Modes*, on page 4-10.

Bit 1 **Reserved.** 0 default.

Bit 0 **PLLPS.** Read/write bit. This bit specifies which of two prescale values will be selected for the System clocks. This bit is cleared (0b) during power-on and system reset, making CPUCLK/4 the default System clock (SYSCLK) frequency. See section 4.2.5, *System Clock (SYSCLK) Frequency Selection*, on page 4-8.

$$0 = f(\text{SYSCLK}) = f(\text{CPUCLK}) / 4$$

$$1 = f(\text{SYSCLK}) = f(\text{CPUCLK}) / 2$$

4.3.2 Clock Control Register 1 (CKCR1)

Figure 4–3. Clock Control Register 1 (CKCR1) — Address 702Dh

7	6	5	4	3	2	1	0
CKINF(3)	CKINF(2)	CKINF(1)	CKINF(0)	PLLDIV(2)	PLLFB(2)	PLLFB(1)	PLLFB(0)
RW-x	RW-x	RW-x	RW-x	RW-x	RW-x	RW-x	RW-x

Note: R = read access; W = write access; -x = not affected by system reset, cleared to 0 by power on reset

Bits 7–4 CKINF(3)–CKINF(0). Read/write bits. These bits indicate the crystal or clock-in frequency being used (Table 4–8). This is used by the WDCLK divider to ensure that a 16 384/15 625 MHz clock is generated.

Table 4–8. CKINF(3:0) Bits vs. Clock-In Frequency (Internal CPU Clock)

CKINF(3:0)	Frequency (MHz)	CKINF(3:0)	Frequency (MHz)
0000	N/A	1000	16
0001	N/A	1001	14
0010	N/A	1010	12
0011	N/A	1011	10
0100	N/A	1100	8
0101	N/A	1101	6
0110	20	1110	4
0111	18	1111	2

Bit 3 PLLDIV(2). Read/write bit. This bit specifies whether the input to the PLL is divide-by-2. Writing to this bit has no effect on the PLL until the CLKMD(1:0) bits are changed from 1 × . This bit is unaffected by system reset and is cleared to 0 by power-on-reset.

- 0 = Do not divide PLL input
- 1 = Divide PLL input by 2

Bits 2–0 **PLLFB(2)–PLLFB(0)**. Read/write bits. These bits specify one of 6 possible PLL multiplication (feedback) ratios (Table 4–9). Writing to this bit has no effect on the PLL until the CLKMD(1:0) bits are changed from $1 \times$. These bits are unaffected by a system reset and are cleared to 0 by a power-on reset.

Table 4–9. PLLFB(2:0) Bits vs. PLL Multiplication Ratio

PLLFB(2:0)	PLL Multiplication Ratio
000	1
001	2
010	3
011	4
100	5
101	9
110	1
111	1

Watchdog and Real-Time Interrupt Module

The watchdog (WD) and real-time interrupt (RTI) module monitors software and hardware operation, provides interrupts at programmable intervals, and implements system reset functions upon CPU disruption. If the software goes into an improper loop, or if the CPU becomes temporarily disrupted, the WD timer overflows to assert a system reset.

The WD/RTI module is part of the TI peripheral module library. It can be combined with other modular building blocks from the TI peripheral module library to generate a diversified family of highly integrated devices.

Topic	Page
5.1 Watchdog (WD) and Real-Time Interrupt (RTI) Overview	5-2
5.2 Operation of Watchdog (WD) and Real-Time Interrupt (RTI) Timers	5-6
5.3 Watchdog (WD) and Real-Time Interrupt (RTI) Control Registers	5-11
5.4 Watchdog (WD) and Real-Time Interrupt (RTI) Routines	5-18

5.1 Watchdog (WD) and Real-Time Interrupt (RTI) Overview

Most conditions that temporarily disrupt chip operation and inhibit proper CPU function can be cleared and reset by the *watchdog* function. By its consistent performance, the watchdog increases the reliability of the CPU, thus ensuring system integrity.

Note: 8-Bit Peripheral

This module is interfaced to the 16-bit peripheral bus as an 8-bit peripheral. Therefore, reads from bits 15–8 are undefined; writes to bits 15–8 have no effect.

5.1.1 WD and RTI Components

The WD/RTI module design includes the following components:

- WD timer
 - 8-bit WD counter that generates a system reset upon overflow
 - 7-bit free-running counter that feeds the WD counter via the WD counter prescale
 - A WD reset key (WDKEY) register that clears the WD counter when the correct combination of values are written, and generates a reset if an incorrect value is written to the register
 - A WD flag (WD FLAG) bit that indicates whether the WD timer initiated a system reset
 - WD check bits that initiate a system reset if the WD timer is corrupted
 - Automatic activation of the WD timer, once system reset is released
 - A WD prescale with six selections from the 7-bit free-running counter and two (identical) WDCLK signal inputs
- RTI timer
 - RTI prescale that selects from 4 taps of the 8-bit real-time counter and 4 taps of the 7-bit free-running counter
 - Interrupt or polled operation (a software bit enables/disables RTI interrupts)
 - An RTI flag (RTI FLAG) bit that indicates whether the RTI counter (RTICNTR) overflows

Figure 5–1 shows a block diagram of the WD/RTI module.

Figure 5–1. Watchdog (WD) and Real-Time Interrupt (RTI) Module Block Diagram

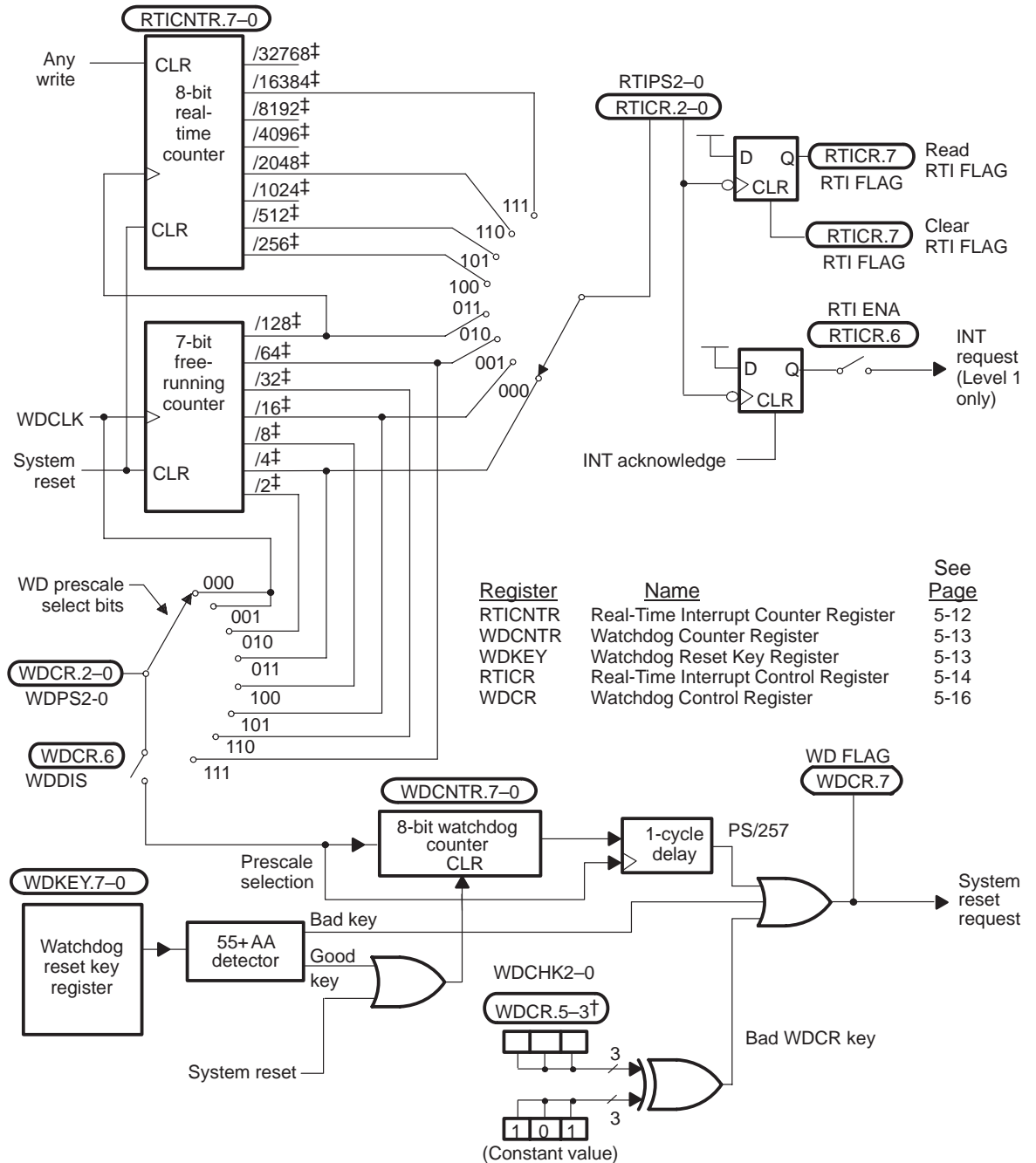

† Writing to bits WDCR.5–3 with anything but the correct pattern (101) generates a system reset.

‡ These prescale values are with respect to the WDCLK signal.

5.1.2 Control Registers

Five registers control the WD/RTI operations:

- ❑ **RTI Counter Register (RTICNTR)** contains the value of the RTI counter.
- ❑ **WD Counter Register (WDCNTR)** contains the value of the WD counter.
- ❑ **WD Reset Key Register (WDKEY)** clears the WDCNTR when a 55h value followed by an AAh value is written to WDKEY.
- ❑ **RTI Control Register (RTICR)** contains the following control bits used for RTI configuration:
 - RTI flag bit
 - RTI enable bit
 - RTI prescale select bits (three)
- ❑ **WD Control Register (WDCR)** contains the following control bits used for watchdog configuration:
 - WD flag bit
 - WD check bits (three)
 - WD prescale select bits (three)

Table 5–1 lists the addresses of the WD/RTI registers.

Table 5–1. Addresses of WD/RTI Module Registers

Address	Register	Name	Described in	
			Section	Page
7020h		Reserved		
7021h	RTICNTR	RTI counter register	5.3.1	5-12
7022h		Reserved		
7023h	WDCNTR	WD counter register	5.3.2	5-13
7024h		Reserved		
7025h	WDKEY	WD reset key register	5.3.3	5-13
7026h		Reserved		
7027h	RTICR	RTI control register	5.3.4	5-14
7028h		Reserved		
7029h	WDCR	WD control register	5.3.5	5-16
702Ah		Reserved		
702Bh		Reserved†		
702Ch		Reserved		
702Dh		Reserved†		
702Eh		Reserved		
702Fh		Reserved		

† Reserved for PLL Clock Module control registers, see Chapter 4, *PLL Clock Module*.

5.2 Operation of Watchdog (WD) and Real-Time Interrupt (RTI) Timers

The WD and RTI module contains two timers – the WD timer and the RTI timer. The WD timer monitors hardware and software operations by providing a system reset if it is not serviced by software having the correct key written. It is enabled by a WD clock signal. The RTI operates by generating periodic interrupts at a specified frequency. These interrupts are software enabled/disabled.

5.2.1 WD Timer

The WD timer is an 8-bit resettable incrementing counter that is clocked by the output of the prescaler. The timer protects against system software failures and CPU disruption by providing a system reset when WDKEY is not serviced before a watchdog overflow. This reset returns the system to a known starting point. Software then clears WDCNTR by writing a correct data pattern to the WD key logic.

A separate internal clocking signal (WDCLK) is generated by the clock module and is active in all operational modes except the oscillator power-down mode. WDCLK enables the WD timer to function, regardless of the state of any register bit(s) on the chip, except during the oscillator power-down mode, which disables the WDCLK signal. The typical WDCLK frequency is 16 384 Hz. The current state of WDCNTR can be read at any time during its operation.

The typical WDCLK frequency of 16 384 Hz is derived from a power of two input clock frequencies (for example, 4.194 MHz, 8.389 MHz). See Chapter 4, *PLL Clock Module*, for more information about the WDCLK signal.

WD prescale select

The 8-bit WDCNTR can be clocked directly by the WDCLK signal or through one of six taps from the free-running counter. The 7-bit free-running counter continuously increments at a rate provided by WDCLK (typically 16 384 Hz or 32 768 Hz, both of which are device specific). The WD functions are enabled as long as WDCLK is provided to the module. Any one of the first six taps or the direct input from WDCLK can be selected by the WD prescale select (bits WDPS2–0) as the input to the time base for the WDCNTR. This prescale provides selectable watchdog overflow rates of from 15.63 ms to 1 second for a WDCLK rate of 16 384 Hz. While the chip is in the normal operating mode, the free-running counter cannot be stopped or reset, except by a system reset. Clearing either RTICNTR or WDCNTR does not clear the free-running counter.

Servicing the WD timer

The WDCNTR is reset when the proper sequence is written to the WDKEY before the WDCNTR overflows. The WDCNTR is enabled for reset when a value of 55h is written to the WDKEY. When the next AAh value is written to the WDKEY, then the WDCNTR actually is reset. Any value written to the WDKEY other than 55h or AAh causes a system reset. Any sequence of 55h and AAh values can be written to the WDKEY without causing a system reset; only a write of 55h followed by a write of AAh to the WDKEY resets the WDCNTR.

Table 5–2 shows a typical sequence written to WDKEY after power up.

Table 5–2. Typical WDKEY Register Power -up Sequence

Sequential Step	Value Written to WDKEY	Result
1	AAh	No action.
2	AAh	No action.
3	55h	WDCNTR is enabled to be reset by the next AAh.
4	55h	WDCNTR is enabled to be reset by the next AAh.
5	55h	WDCNTR is enabled to be reset by the next AAh.
6	AAh	WDCNTR is reset.
7	AAh	No action.
8	55h	WDCNTR is enabled to be reset by the next AAh.
9	AAh	WDCNTR is reset.
10	55h	WDCNTR is enabled to be reset by the next AAh.
11	23h	System reset due to an improper key value written to WDKEY.

Step 3 in Table 5–2 is the first action to enable the WDCNTR to be reset. The WDCNTR is not actually reset until step 6. Step 8 re-enables the WDCNTR to be reset, and step 9 resets the WDCNTR. Step 10 again re-enables the WDCNTR to be reset. Writing the wrong key value to the WDKEY in step 11 causes a system reset.

A WDCNTR overflow or an incorrect key value written to the WDKEY also sets the WD flag (WDFLAG). After a reset, the program reads this flag to determine the source of the reset. After reset, WDFLAG should be cleared by the software to allow the source of subsequent WD resets to be determined. WD resets are not prevented when the flag is set.

WD reset

When the WDCNTR overflows, the WD timer asserts a system reset. Reset occurs one WDCNTR clock cycle (either WDCLK or WDCLK divided by a prescale value) later. The reset cannot be disabled in normal operation as long as WDCLK is present. The WD timer is, however, disabled in the oscillator power-down mode when WDCLK is not active.

WD disable

For development purposes, the WD timer can be disabled by applying 5V to the V_{CCP} pin during the device reset sequence and setting the WDDIS bit in the WD control register (WDCR.6). However, if the hardware and software conditions are not met, the WD timer will not be disabled.

WD check bit logic

The WD check bits (WDCR.5–3, described in detail in section 5.3.5, *WD Timer Control Register*, on page 5-16) are continuously compared to a constant value (101_2). If the WD check bits do not match this value, a system reset is generated. This functions as a logic check in case the software improperly writes to the WDCR, or if an external stimulus (such as voltage spikes, EMI, or other disruptive sources) corrupt the contents of the WDCR. Writing to bits WDCR.5–3 with anything but the correct pattern (101_2) generates a system reset.

Note: WDCR Required Values

Any values written to WDCR must include the value 101_2 written to bits 5–3 (WDCHK2 – WDCHK0).

WD setup

The WD timer operates independently of the CPU and is always enabled. It does not need any CPU initialization to function. When a system reset occurs, the WD timer defaults to the fastest WD timer rate available (15.63 ms for a 16 384 Hz WDCLK signal). As soon as reset is released internally, the CPU starts executing code, and the WD timer begins incrementing. This means that, to avoid a premature reset, WD/RTI setup should occur early in the power-up sequence.

5.2.2 RTI timer

The RTI timer is an 8-bit counter that can be programmed to generate periodic interrupts at a software-selectable frequency. Eight taps in all—four from the RTI counter (RTICNTR, further described in section 5.3.1 on page 5-12) and four from the free-running counter—can be selected through a 1-of-8 multiplexer to generate the frequency of the periodic interrupt requests. The interrupts are enabled and disabled through software. The RTICNTR can be read or cleared at any time. The 7-bit free-running counter, however, cannot be cleared except by system reset.

The actual memory-mapped location of the RTI interrupt vector is device specific. The CPU always accesses the information in a vector in the same manner, regardless of the device, although the physical locations of the vectors may differ. Consult the specific device data sheet (Literature number SPRS042) for the actual physical location of the RTI interrupt vector.

RTI prescale select

The RTICNTR (RTI counter, described in section 5.3.1 on page 5-12) uses the /128 (divide-by-128) tap from the free-running counter as an input to generate four output taps. These four taps, plus four additional taps taken from the free-running counter can be selected through a 1-of-8 multiplexer that is controlled through the three prescale select bits of the RTI control register (RTICR.2–0, described in section 5.3.4 on page 5-14). This prescale provides selectable interrupt rates of from 1 to 4096 interrupts per second (16 384 Hz WDCLK signal). The RTICNTR is clocked by the WDCLK signal. The RTICNTR can be reset to 00h at any time during normal operation. RTI timer functions are enabled in all modes except the halt mode.

Clearing the RTICNTR with software does not clear the free-running counter, which provides the RTICNTR prescale. Therefore, after the RTICNTR is cleared, timing measurements from this counter yield up to a 1-bit uncertainty.

RTI enable

The RTI can be enabled or disabled through the RTI enable bit (RTI ENA), which is bit 6 of the RTI control register (RTICR.6). When the RTI is enabled, it allows an interrupt to be generated when the selected overflow occurs. The interrupt logic generates only one interrupt for each transition on the selected tap.

Because the free-running counter cannot be cleared by software, the software logic assumes that the time period specified is measured between consecutive overflows of RTICNTR. Therefore, the timing of the first interrupt cannot be predicted. Accurate timing is provided by waiting until RTI FLAG (RTICR.7) acknowledges the first overflow before enabling the interrupt.

RTI flag

The RTI flag bit (RTIFLAG) indicates that an overflow has occurred. This is bit 7 of the RTI control register (RTICR.7). The bit can be cleared by software servicing the RTI timer; however, clearing the bit is not required for interrupt generation, and setting the bit with software does not generate an interrupt.

5.3 Watchdog (WD) and Real-Time Interrupt (RTI) Control Registers

The WD/RTI module control registers are shown in Figure 5–2 and discussed in detail in the following sections.

Figure 5–2. WD/RTI Module Control Registers

Address	Register	Bit number							
		7	6	5	4	3	2	1	0
7020h	—	Reserved							
7021h	RTICNTR	D7	D6	D5	D4	D3	D2	D1	D0
7022h	—	Reserved							
7023h	WDCNTR	D7	D6	D5	D4	D3	D2	D1	D0
7024h	—	Reserved							
7025h	WDKEY	D7	D6	D5	D4	D3	D2	D1	D0
7026h	—	Reserved							
7027h	RTICR	RTI FLAG	RTI ENA	Reserved			RTIPS2	RTIPS1	RTIPS0
7028h	—	Reserved							
7029h	WDCR	WD FLAG	WDDIS	WDCHK2	WDCHK1	WDCHK0	WDPS2	WDPS1	WDPS0
702Ah	—	Reserved							
702Bh	—	Reserved†							
702Ch	—	Reserved							
702Dh	—	Reserved†							
702Eh	—	Reserved							
702Fh	—	Reserved							

† Reserved for PLL Clock Module control registers, see Chapter 4, *PLL Clock Module*.

5.3.1 Real-Time Interrupt Counter Register (RTICNTR)

The 8-bit real-time interrupt counter register (RTICNTR) contains the value of the real-time counter. It continuously increments using the /128 (128-Hz) overflow from the free-running counter. Although this is an 8-bit counter, only 7 bits are actually needed for the RTI function. The eighth bit (bit 7) can be read and used as an RTI extension bit. The RTICNTR does not stop while the device is in the normal run mode, idle 1 mode, idle 2 mode, or PLL power-down mode.

Figure 5–3. Real-Time Interrupt Counter Register (RTICNTR) — Address 7021h

7	6	5	4	3	2	1	0
D7	D6	D5	D4	D3	D2	D1	D0
RC-0	RC-0	RC-0	RC-0	RC-0	RC-0	RC-0	RC-0

Note: R = read access, C = clear, -0 = value after reset

Bits 7–0 **D7–D0.** Data values. These read-only data bits contain the 8-bit RTI counter value. Writing any value to this register clears it to 0.

Note: Counter Not Cleared When RTICNTR is Cleared

The free-running counter that prescales RTICNTR is not cleared when RTICNTR is cleared. This gives a cumulative maximum uncertainty of one RTICNTR bit when RTICNTR is used for time measurement.

5.3.2 WD Counter Register (WDCNTR)

The 8-bit WD counter register (WDCNTR) contains the current value of the WD counter. This register continuously increments at a rate selected through the WD control register. When this register overflows, an additional single-cycle (either WDCLK or WDCLK divided by a prescale value) delay is incurred before system reset is asserted. This allows the RTI timer and the WD timer to be programmed to the same period, while still giving the program time to write the proper WD key sequence. Writing the proper sequence to the WD reset key register clears WDCNTR and prevents a system reset; however, this does not clear the free-running counter.

Figure 5–4. WD Counter Register (WDCNTR) — Address 7023h

7	6	5	4	3	2	1	0
D7	D6	D5	D4	D3	D2	D1	D0
R–0	R–0	R–0	R–0	R–0	R–0	R–0	R–0

Note: R = read access, –0 = value after reset

Bits 7–0 **D7–D0.** Data values. These read-only data bits contain the 8-bit WD counter value. Writing to this register has no effect.

5.3.3 WD Reset Key Register (WDKEY)

The WD reset key register (WDKEY) clears WDCNTR when a 55h value followed by an AAh value is written to WDKEY. Any combination of AAh and 55h is allowed, but only a 55h followed by an AAh resets the counter. Any other value causes a system reset.

Figure 5–5. WD Reset Key Register (WDKEY) — Address 7025h

7	6	5	4	3	2	1	0
D7	D6	D5	D4	D3	D2	D1	D0
RW–0	RW–0	RW–0	RW–0	RW–0	RW–0	RW–0	RW–0

Note: R = read access, W = write access, –0 = value after reset

Bits 7–0 **D7–D0.** Data values. These write-only data bits contain the 8-bit WD reset key value. When read, WDKEY does *not* return the last key value but rather returns the contents of WDCR.

5.3.4 RTI Control Register (RTICR)

Figure 5–6. RTI Control Register (RTICR) — Address 7027h

7	6	5 – 3	2	1	0
RTI FLAG	RTI ENA	Reserved	RTIPS2	RTIPS1	RTIPS0
RW–0	RW–0		RW–0	RW–0	RW–0

Note: R = read access, W = write access, –0 = value after reset

Bit 7 **RTI FLAG.** Real-time interrupt flag bit. This status bit shows if an overflow occurred. The bit can be cleared by software servicing the RTI (writing a 0 clears the bit). Clearing this bit is not required for interrupt generation. Setting this bit does not cause an interrupt to be generated.

- 0 = Overflow has not occurred.
- 1 = Overflow has occurred.

Bit 6 **RTI ENA.** Real-time interrupt enable bit. This bit allows an interrupt to be generated when the selected overflow occurs. Clearing this bit clears any pending interrupt request not yet acknowledged. The interrupt is issued based on the value of the free-running counter (and RTICNTR for frequencies of 64 Hz and slower). Only a single interrupt is requested on the leading edge of an overflow.

- 0 = Clears any pending interrupt request not acknowledged and disables future RTI interrupts.
- 1 = Enables interrupts to be generated when the RTI flag detects an overflow.

Note:

The value of the free-running counter is software independent. The software should assume only that the time period specified is measured between consecutive interrupts. Software cannot predict when the first interrupt will occur, except as measured from system reset.

Bits 5–3 **Reserved.** Writing to these bits has no effect. These bits are always read as 0.

Bits 2–0 **RTIPS2–RTIPS0.** Real-time interrupt prescale select bits. These bits select the divider tap used to generate an interrupt. Table 5–3 shows timing data with the assumption that the WDCLK is running at a nominal frequency of 16 384 Hz or 15 625 Hz.

Table 5–3. Real-Time Interrupt Selections

RTI Prescale Select Bits			WDCLK Divider	16.384 kHz WDCLK [†]		15.625 kHz WDCLK [‡]	
RTIPS2	RTIPS1	RTIPS0		Frequency (Hz)	Overflow Time	Frequency (Hz)	Overflow Time
0	0	0	4	4096	244.14 μ s	3906.25	256 μ s
0	0	1	16	1024	976.56 μ s	976.56	1.024 ms
0	1	0	64	256	3.91 ms	244.14	4.096 ms
0	1	1	128	128	7.81 ms	122.07	8.192 ms
1	0	0	256	64	15.63 ms	61.04	16.384 ms
1	0	1	512	32	31.25 ms	30.52	32.768 ms
1	1	0	2048	8	125.00 ms	7.63	131.072 ms
1	1	1	16 384	1	1.0 second	0.95	1.049 second

[†] Can be generated by a 4.194 MHz crystal

[‡] Can be generated by a 4.00 MHz crystal

5.3.5 WD Timer Control Register (WDCR)

Figure 5–7. WD Timer Control Register (WDCR) — Address 7029h

7	6	5	4	3	2	1	0
WD FLAG	WDDIS	WDCHK2	WDCHK1	WDCHK0	WDPS2	WDPS1	WDPS0
RW-x		RW-0	RW-0	RW-0	RW-0	RW-0	RW-0

Note: R = read access, W = write access, -n = value after reset (x = indeterminate)

Note: WDCR Required Values

Any values written to WDCR must include the value 101₂ written to bits 5–3 (bits WDCHK2 – WDCHK0).

- Bit 7** **WD FLAG.** Watchdog flag bit. This bit indicates whether a system reset was asserted by the WD timer. The bit is set to 1 by a WD-generated reset. It is unaffected by any other type of system reset.

 - 0 = Indicates that the WD timer has not asserted a reset since the bit was last cleared.
 - 1 = Indicates that the WD timer has asserted a reset since the bit was last cleared.

- Bit 6** **WDDIS.** Watchdog disable. This bit is valid (available to the user) only when the HP0 bit in the SYSCR (system control register) is set. This only occurs if pin V_{CCP} is at 5V during the device reset sequence. See Chapter 6, *System Functions*, for more information.

 - 0 = Watchdog is enabled.
 - 1 = Watchdog is disabled.

- Bit 5** **WDCHK2.** Watchdog check bit 2. This bit must be written as a 1 when you write to WDCR, or else a system reset is asserted. This bit is always read as 0.

 - 0 = System reset is asserted.
 - 1 = Normal operation continues if all check bits are written correctly.

- Bit 4** **WDCHK1.** Watchdog check bit 1. This bit must be written as a 0 when you write to WDCR, or else a system reset is asserted. This bit is always read as 0.

 - 0 = Normal operation continues if all check bits are written correctly.
 - 1 = System reset is asserted.

- Bit 3** **WDCHK0.** Watchdog check bit 0. This bit must be written as a 1 when you write to WDCR, or else a system reset is asserted. This bit is always read as 0.

 - 0 = System reset is asserted.
 - 1 = Normal operation continues if all check bits are written correctly.

Bits 2–0 **WDPS2–WDPS0.** Watchdog prescale select bits. These bits select the counter overflow tap that generates a reset. Each selection sets up the maximum time elapsed before servicing the WD key logic. All timing assumes that the WDCLK is running at 16 384 Hz. Because the WD timer counts 257 clocks before overflowing, the times given are the minimum for overflow (reset). The maximum timeout can be up to 1/256 longer than the times listed in Table 5–4 because of the added uncertainty resulting from not clearing the prescaler.

Table 5–4. WD Overflow (Timeout) Selections

WD Prescale Select Bits			WDCLK Divider	16.384 kHz WDCLK [‡]		15.625 kHz WDCLK [§]	
WDPS2	WDPS1	WDPS0		Frequency (Hz)	Minimum Overflow	Frequency (Hz)	Minimum Overflow
0	0	X [†]	1	64	15.63 ms	61.04	16.38 ms
0	1	0	2	32	31.25 ms	30.52	32.77 ms
0	1	1	4	16	62.50 ms	15.26	65.54 ms
1	0	0	8	8	125.00 ms	7.63	131.07 ms
1	0	1	16	4	250.00 ms	3.81	262.14 ms
1	1	0	32	2	500.00 ms	1.91	524.29 ms
1	1	1	64	1	1.0 second	0.95	1.05 second

[†] X = Don't care

[‡] Can be generated by a 4.194 MHz crystal

[§] Can be generated by a 4.00 MHz crystal

5.4 Watchdog (WD) and Real-Time Interrupt (RTI) Routines

Example 5–1 shows a WD/RTI enable routine and Example 5–2 shows a WD/RTI disable routine for the DSP controller.

Example 5–1. Watchdog (WD) and Real-Time Interrupt (RTI) Enable Routine

```

;*****
; File Name:   Watchdog Enable Example Code
;
; Description: The sample code below demonstrates the software required
;              to enable the watchdog with an overflow time of 1.05
;              seconds. The watchdog counter must be reset before the
;              counter overflows in order to avoid a watchdog reset.
;              The KICK_DOG macro is used to reset the watchdog counter.
;              This macro should be placed throughout the main body of
;              code to ensure that the counter is indeed reset.
;
;              Note:  The code listed below is not a complete program.
;                    It only demonstrates the steps required to enable
;                    the watchdog.
;-----
; Macro definitions
;-----
KICK_DOG      .macro                ;watchdog reset macro
               LDP    #00E0h
               SPLK  #05555h, WDKEY
               SPLK  #0AAAAh, WDKEY
               LDP   #0h
               .endm
;=====
; M A I N   C O D E   - starts here
;=====
               .text
START:        LDP    #00E0h
               SPLK  #002Fh, WDCR ;Enable watchdog w/max. overflow
               KICK_DOG          ;Reset watchdog counter
;=====
; Main Program Routine
;=====
MAIN:         ;Main loop of code begins here
;             ...             ;Insert actual code here
               KICK_DOG        ;Reset watchdog counter
;             ....           ;Insert actual code here
               KICK_DOG        ;Reset watchdog counter
               B      MAIN      ;The MAIN program loop has completed
;                               ;one pass, branch back to the
;                               ;beginning and continue.

```

Example 5–2. Watchdog (WD) and Real-Time Interrupt (RTI) Disable Routine

```

;*****
; File Name:   Watchdog Disable Example Code
;
; Description: The sample code below demonstrates the software required
;              to disable the watchdog when 5 volts is applied to the
;              Vccp pin on the device.  After the watchdog has been
;              disabled, the watchdog counter must be reset in order to
;              clear the pending interrupt.  The KICK_DOG macro is used
;              to reset the watchdog counter.
;              Note:  The code listed below is not a complete program.
;                    It only demonstrates the steps required to disable
;                    the watchdog.
;-----
; Macro definitions
;-----
KICK_DOG      .macro                ;Watchdog reset macro
               LDP    #00E0h
               SPLK   #055h, WDKEY
               SPLK   #0AAh, WDKEY
               LDP    #0h
               .endm
;=====
; M A I N   C O D E  -  starts here
;=====
               .text
START:        LDP    #00E0h
               SPLK   #006Fh, WDCR ;Disable watchdog if VCCP=5V
               KICK_DOG          ;Reset Watchdog counter
;=====
; Main Program Routine
;=====
MAIN:         ;Main loop of code begins here ...
;
               ;insert actual code here
               NOP
               NOP
               NOP
;
               .... ;insert actual code here
               B     MAIN ;The MAIN program loop has completed
                       ;one pass, branch back to the
                       ;beginning and continue.

```

Event Manager Module

This chapter describes the 'C240/'F240 event manager (EV) module in the peripheral library. The EV module includes timers, compare units, simple compares, a capture unit, and a quadrature encoder pulse (QEP) circuit.

Topic	Page
6.1 Event Manager (EV) Module Overview	6-2
6.2 Event Manager (EV) Register Addresses	6-8
6.3 General Purpose (GP) Timer	6-11
6.4 GP Timer Counting Operation	6-19
6.5 GP Timer Compare Operation	6-34
6.6 GP Timer Control Registers (TxCON and GPTCON)	6-40
6.7 Generation of Compare and PWM Outputs Using GP Timers	6-45
6.8 Compare Units	6-47
6.9 PWM Circuits Associated With Full Compare Units	6-59
6.10 PWM Waveform Generation With Compare Units and PWM Circuits	6-69
6.11 Space-Vector PWM	6-74
6.12 Capture Units	6-80
6.13 Quadrature Encoder Pulse (QEP) Circuit	6-91
6.14 Event Manager (EV) Interrupts	6-95

6.1 Event Manager (EV) Module Overview

The EV module provides a broad range of functions and features that are particularly useful in motion-control and motor-control applications.

Note: Sharing device pins

The device pins used by the EV module can be shared between EV and other modules. See Chapter 1 for TMS320C240 specific pin sharing information.

6.1.1 EV Functional Blocks

Figure 6–1 shows a block diagram of the EV module containing the following functional blocks:

- Three general-purpose (GP) timers (see section 6.3 on page 6-11)
- Three full compare units (see section 6.8.2 on page 6-48)
- Three simple compare units (see section 6.8.1 on page 6-47)
- Pulse-width modulation (PWM) circuits that include:
 - A space-vector PWM circuit (see section 6.9 on page 6-59)
 - Dead-band generation units (see section 6.10 on page 6-69)
 - Output logic (see section 6.11 on page 6-74)
- Four capture units (see section 6.12 on page 6-80)
- Quadrature encoder pulse (QEP) circuit (see section 6.13 on page 6-91)
- EV interrupts (see section 6.14 on page 6-95)

Figure 6–1. Event Manager (EV) Block Diagram

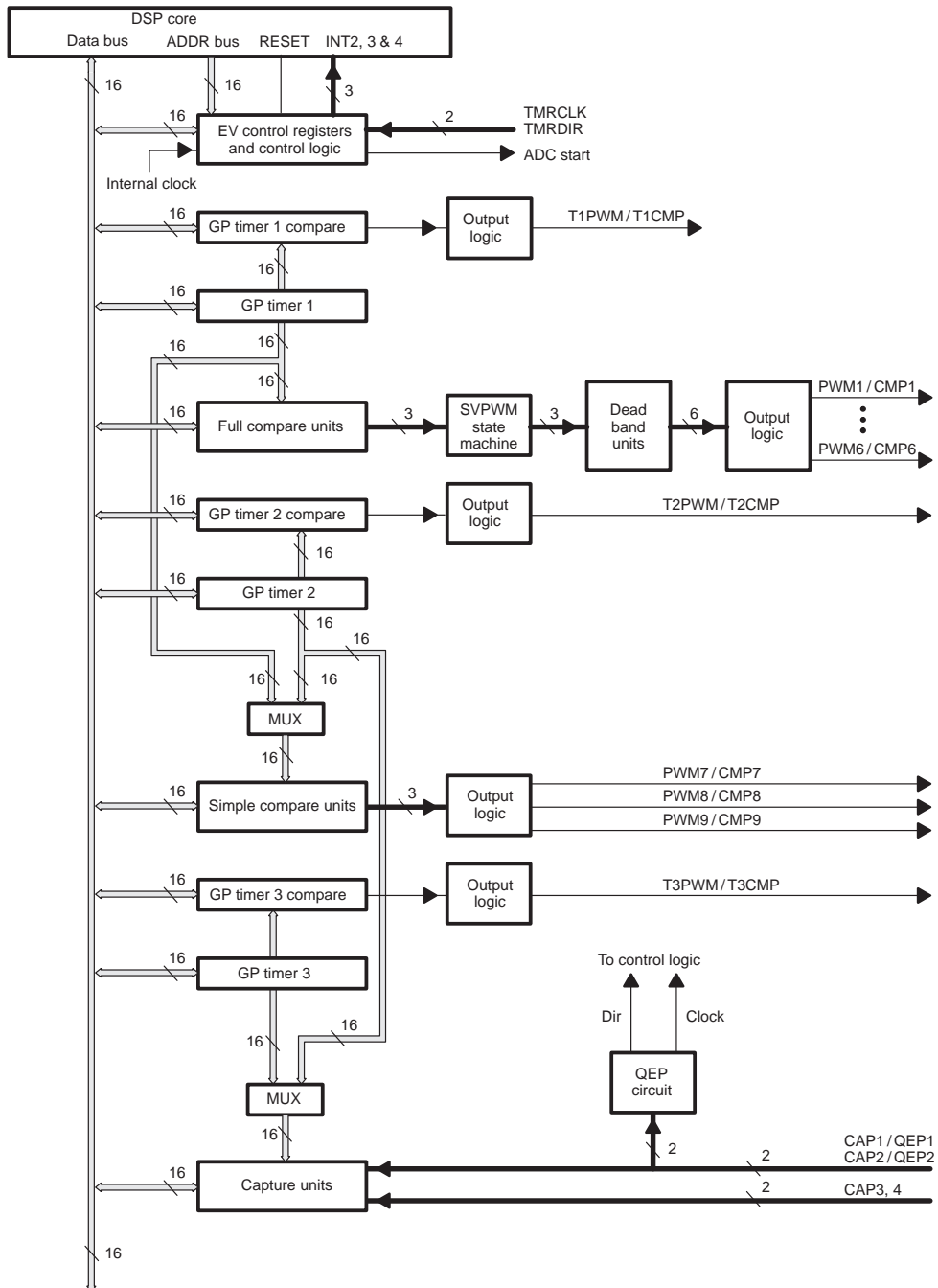

6.1.2 EV Pins

The EV module uses 12 device pins for compare/PWM outputs:

- ❑ Three GP timer compare/PWM output pins:
 - T1PWM/T1CMP
 - T2PWM/T2CMP
 - T3PWM/T3CMP

- ❑ Six full compare/PWM output pins:
 - PWM1/CMP1
 - PWM2/CMP2
 - PWM3/CMP3
 - PWM4/CMP4
 - PWM5/CMP5
 - PWM6/CMP6

- ❑ Three simple compare/PWM output pins:
 - PWM7/CMP7
 - PWM8/CMP8
 - PWM9/CMP9

The EV module uses four device pins, CAP1/QEP1, CAP2/QEP2, CAP3, and CAP4, as capture or quadrature encoder pulse inputs.

The GP timers in the EV module can be programmed to operate based on an external or internal CPU clock. The device pin TMRCLK supplies the external clock input.

The device pin TMRDIR is used to specify the counting direction when a GP timer is in directional up/down counting mode.

All inputs to the EV module are synchronized with the internal CPU clock. A transition must hold until two rising edges of the CPU clock (or two falling edges of CLKOUT, if the CPU clock has been chosen as source for CLKOUT output) are met before it is recognized by the EV. Therefore, it is recommended that all transitions be held for more than two CPU clock cycles.

Device pins are summarized in Table 6–1 on page 6-5.

Table 6–1. EV Pins

Pin Name	Description
CAP1/QEP1	Capture unit 1 input, QEP circuit input 1
CAP2/QEP2	Capture unit 2 input, QEP circuit input 2
CAP3	Capture unit 3 input
CAP4	Capture unit 4 input
PWM1/CMP1	Full compare unit 1 compare/PWM output 1
PWM2/CMP2	Full compare unit 1 compare/PWM output 2
PWM3/CMP3	Full compare unit 2 compare/PWM output 1
PWM4/CMP4	Full compare unit 2 compare/PWM output 2
PWM5/CMP5	Full compare unit 3 compare/PWM output 1
PWM6/CMP6	Full compare unit 3 compare/PWM output 2
PWM7/CMP7	Simple compare unit 1 compare/PWM output
PWM8/CMP8	Simple compare unit 2 compare/PWM output
PWM9/CMP9	Simple compare unit 3 compare/PWM output
T1PWM/T1CMP	GP timer 1 compare/PWM output
T2PWM/T2CMP	GP timer 2 compare/PWM output
T3PWM/T3CMP	GP timer 3 compare/PWM output
TMRCLK	GP timer external clock input
TMRDIR	GP timer external direction input

6.1.3 Power-Drive Protection

An external interrupt is generated when the device pin PDPINT (power-drive-protection interrupt) is pulled low. This interrupt is provided for the safe operation of systems such as power converters and motor drives. If PDPINT is unmasked, all EV output pins are put in the high-impedance state by hardware immediately after the PDPINT pin is pulled low. The interrupt flag associated with PDPINT is also set when the PDPINT pin is pulled low; however, it must wait until the transition on PDPINT has been qualified and synchronized with the internal CPU clock. The qualification and synchronization causes a delay of three to four CPU clock cycles. If PDPINT is unmasked, the flag keeps the EV outputs in the high-impedance state and generates an interrupt request to

the DSP core. Therefore, for the outputs to remain in high impedance, PDPINT must be held low for longer than four CPU clock cycles. The setting of the flag does not depend on whether PDPINT is masked. The flag is set as long as a qualified transition has occurred on the PDPINT pin. PDPINT can be used to inform the monitoring program of motor drive abnormalities, such as overvoltages, overcurrents, and excessive temperature rises.

6.1.4 EV Registers

All registers in the EV module are mapped to data memory. Their addresses take up 64 (16-bit) words of the 64K words of data-memory address range. The registers are treated by software as data memory locations and can be accessed by a wide range of DSP instructions. The undefined bits in the EV registers return 0s when read by user software (see Section 6.2, *Event Manager (EV) Register Addresses*, on page 6-8).

6.1.5 EV Interrupts

The interrupts generated by the EV module are arranged into three groups. There are three registers, EVIFRA, EVIFRB, and EVIFRC, in the EV for the flags of the three groups of interrupts. The three groups of interrupts are connected to three of the CPU interrupt inputs. Each EV interrupt group has an associated interrupt vector register, EVIFVR_x ($x = A, B, \text{ and } C$), that can be read by user software to get the vector (ID) of an interrupt source. Each interrupt source has a unique interrupt vector ID.

An interrupt flag is set when an interrupt event (for example, a match between a compare register and a GP timer) is generated and enabled. There is an interrupt mask register, EVIMR_x ($x = A, B, \text{ or } C$), associated with each EV interrupt group. An interrupt is masked if its corresponding bit in EVIMRA, EVIMRB, or EVIMRC is 0, and unmasked if the corresponding bit is 1. An interrupt request is generated to the CPU by an interrupt group if there is an interrupt flag in the group that is set and unmasked.

The set and reset of interrupt flags are independent of whether the corresponding interrupts are masked. The interrupt flag can, therefore, be checked by software to verify the occurrence of an event when the corresponding interrupt is masked. An interrupt flag can be reset to 0 in two ways:

- User software writes a 1 to the corresponding bit in EVIFRA, EVIFRB, or EVIFRC.
- User software reads its interrupt vector ID after an interrupt request generated by its group has been taken.

After a group generated interrupt request is taken and the interrupt vector is read, the vector ID of the highest priority flag (among those that were set and unmasked) is loaded into the accumulator. A 0 value is returned when the interrupt vector register of an interrupt group is read and no interrupt flag in the group is set and unmasked. This prevents a strayed interrupt from being recognized as an EV interrupt.

Details of an interrupt event generation are described in the sections that follow. Details of request generation, service, and priority of all EV interrupts are summarized in Section 6.14, *Event Manager Interrupts*, on page 6-95.

6.2 Event Manager (EV) Register Addresses

Table 6–2 through Table 6–5 list the addresses of the EV registers.

Table 6–2. Addresses of GP Timer Registers

Address	Register	Name	Described in	
			Section	Page
7400h	GPTCON	General-purpose timer control register	6.6	6-40
7401h	T1CNT	GP timer 1 counter register	6.3	6-11
7402h	T1CMPR	GP timer 1 compare register	6.3	6-11
7403h	T1PR	GP timer 1 period register	6.3	6-11
7404h	T1CON	GP timer 1 control register	6.6	6-40
7405h	T2CNT	GP timer 2 counter register	6.3	6-11
7406h	T2CMPR	GP timer 2 compare register	6.3	6-11
7407h	T2PR	GP timer 2 period register	6.3	6-11
7408h	T2CON	GP timer 2 control register	6.6	6-40
7409h	T3CNT	GP timer 3 counter register	6.3	6-11
740Ah	T3CMPR	GP timer 3 compare register	6.3	6-11
740Bh	T3PR	GP timer 3 period register	6.3	6-11
740Ch	T3CON	GP timer 3 control register	6.6	6-40

Table 6–3. Addresses of Full and Simple Compare Unit Registers

Address	Register	Name	Described in	
			Section	Page
7411h	COMCON	Compare control register	6.8.8	6-51
7413h	ACTR	Full compare action control register	6.8.8	6-51
7414h	SACTR	Simple compare action control register	6.8.8	6-51
7415h	DBTCON	Dead-band timer control register	6.9.2	6-61
7417h	CMPR1	Full compare unit compare register 1	6.8.2	6-48
7418h	CMPR2	Full compare unit compare register 2		
7419h	CMPR3	Full compare unit compare register 3		
741Ah	SCMPR1	Simple compare unit compare register 1	6.8.1	6-47
741Bh	SCMPR2	Simple compare unit compare register 2		
741Ch	SCMPR3	Simple compare unit compare register 3		

Table 6–4. Addresses of Capture Unit and Quadrature Encoder Pulse Decoding Circuit Registers

Address	Register	Name	Described in	
			Section	Page
7420h	CAPCON	Capture control register	6.12.3	6-82
7422h	CAPFIFO	Capture FIFO status register	6.12.3	6-82
7423h	CAP1FIFO	Capture Unit 1 FIFO stack	6.12.4	6-87
7424h	CAP2FIFO	Capture Unit 2 FIFO stack		
7425h	CAP3FIFO	Capture Unit 3 FIFO stack		
7426h	CAP4FIFO	Capture Unit 4 FIFO stack		

Table 6–5. Addresses of EV Interrupt Registers

Address	Register	Name	Described in	
			Section	Page
742Ch	EVIMRA	Interrupt mask registers	6.14.3	6-99
742Dh	EVIMRB			
742Eh	EVIMRC			
742Fh	EVIFRA	Interrupt flag registers	6.14.3	6-99
7430h	EVIFRB			
7431h	EVIFRC			
7432h	EVIVRA	Interrupt vector registers	6.14.3	6-99
7433h	EVIVRB			
7434h	EVIVRC			

6.3 General-Purpose (GP) Timers

There are three general-purpose (GP) timers in the EV module. These timers can be used as independent time bases in applications such as:

- Providing a time base for the operation of full and simple compare units and associated PWM circuits to generate compare/PWM outputs
- Generation of sampling period in a control system
- Providing a time base for the operation of QEP circuits and capture units

6.3.1 GP Timer Functional Blocks

Figure 6–2 shows a block diagram of the GP timers. Each GP timer includes:

- One read/write (R/W) 16-bit up and up/down counter, TxCNT (x = 1, 2, 3)
- One R/W 16-bit timer compare register (shadowed), TxCMPR (x = 1, 2, 3)
- One R/W 16-bit timer period register (shadowed), TxPR (x = 1, 2, 3)
- One R/W 16-bit control register, TxCON (x = 1, 2, 3)
- Programmable prescaler applicable to both internal and external clock inputs
- Control and interrupt logic
- One GP timer compare output pin, TxPWM/TxCMP (x = 1, 2, 3)
- Output logic

Another control register, GPTCON, specifies the action to be taken by the GP timers on different timer events and indicates the counting directions of all three GP timers. GPTCON is readable and writable; however, writing to the three status bits has no effect.

Figure 6–2. GP Timer Block Diagram (x = 1, 2, or 3)

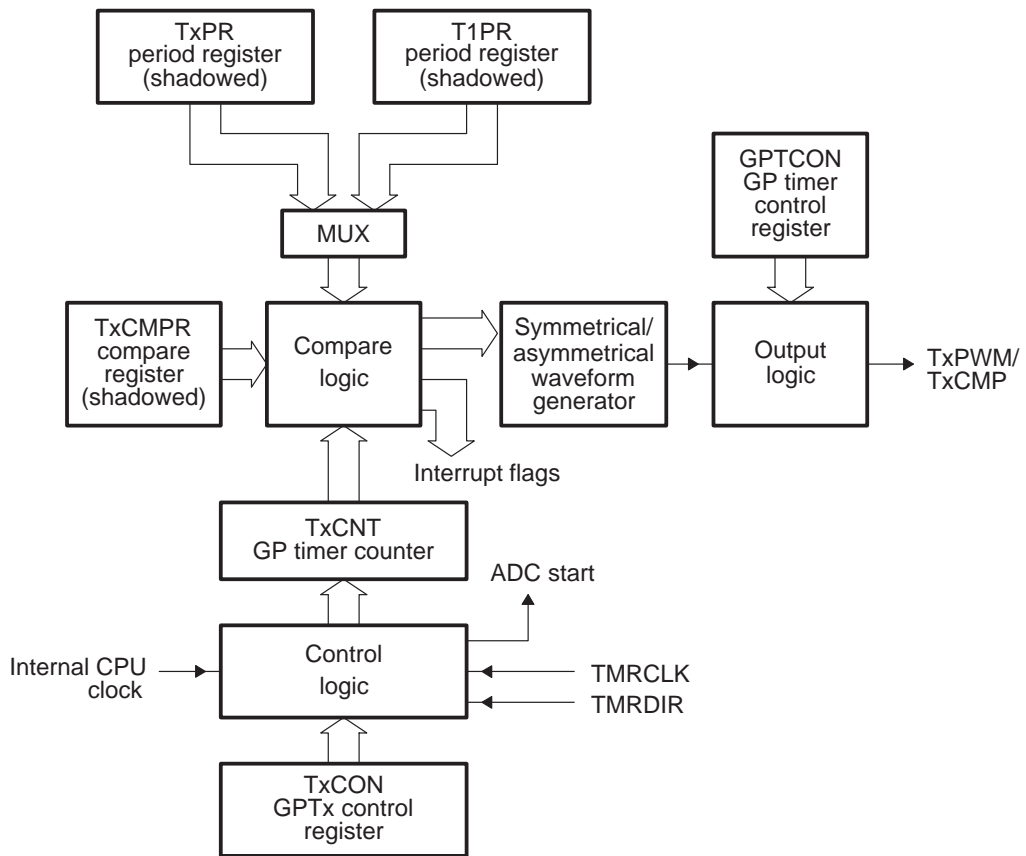

6.3.2 GP Timer Inputs

The inputs to GP timers are:

- Internal CPU clock, which comes directly from the core and hence has the same frequency as that of the CPU clock
- External clock, TMRCLK, which has a maximum frequency of one-fourth that of the CPU clock
- Direction input, TMRDIR, for use by the GP timer in directional-up/down counting mode
- Reset signal, RESET

In addition, GP timer 3 takes the overflow of GP timer 2 as the input clock when GP timers 2 and 3 are cascaded into a 32-bit timer. When a GP timer is used with the QEP circuit, the QEP circuit generates both the timer’s clock and counting direction.

6.3.3 GP Timer Outputs

The outputs of the GP timers are:

- GP timer compare/PWM outputs TxPWM/TxCMP, x = 1, 2, 3
- ADC start signal to ADC module
- Underflow, overflow, compare match, and period match signals to its own compare logic, and to full and simple compare units
- Counting direction indication bits

6.3.4 Control of GP Timer Operation

The operation mode of a GP timer is controlled by its control register, TxCON. Bits in the TxCON register determine:

- Whether the timer is enabled or disabled
- Which of the six counting modes the GP timer is in
- Whether the internal or external CPU clock is to be used by the GP timer
- Which of the six prescale factors for input clock (ranging from 1 to 1/128) is to be used
- Which condition the timer compare register is in when reloaded
- Whether the GP timer compare operation is enabled or disabled
- Whether the period register of GP timer 1 or its own period register determines its period (T2CON and T3CON only)
- Whether the carry bit (carryover) of GP timer 2 should be used as its clock (T3CON only)

6.3.5 GP Timer Control Register (GPTCON)

The control register GPTCON specifies the action to be taken by the GP timers on different timer events and indicates their counting directions.

6.3.6 GP Timer Compare Registers

The compare register associated with a GP timer stores the value to be constantly compared with the counter of the GP timer. When a match is detected, the following events occur:

- Transition on the associated compare/PWM output
- Start of ADC according to the bit pattern in GPTCON
- The corresponding compare interrupt flag is set.

This operation can be enabled or disabled by bit 1 of TxCON.

6.3.7 GP Timer Period Register

The value in the period register of a GP timer determines the period of the timer. The operation of a GP timer stops and holds at its current value, resets to 0, or starts counting downward when a match occurs between the period register and the timer counter, depending on the counting mode of the timer.

6.3.8 Double Buffering of GP Timer Compare and Period Registers

The compare and period registers, TxCMPR and TxPR, of a GP timer are shadowed. A new value can be written to either of these registers at any time during a period; however, the new value is written to the associated shadow register.

For the compare register, the content in the shadow register is loaded into the working (active) register only when a certain timer event specified by TxCON occurs.

The compare register is reloaded on any of the following conditions:

- Immediately after the shadow register is written
- On underflow; that is, when the GP timer counter value is 0
- On underflow or period match; that is, when the counter value is 0 or when the counter value equals the value of the period register

For the period register, the working register is reloaded with the value in its shadow register only when the value of the counter register TxCNT is 0.

The double-buffering feature allows the application code to update the compare and period registers at any time during a cycle. This changes the timer period and the width of the the PWM pulse for the following cycle. On-the-fly change of the timer period value, in the case of PWM generation, means on-the-fly change of the PWM carrier frequency.

Notes: Initialize period registers, compare register transparency

- 1) The period register of a GP timer should be initialized before its counter is initialized to a nonzero value. Otherwise, the value of the period register will remain unchanged until the next underflow.
- 2) A compare register is transparent (the newly loaded value goes directly into the active register) when the associated compare operation is disabled. This applies to all compare registers in the EV.

6.3.9 GP Timer Compare/PWM Output

The compare/PWM output of a GP timer can be specified active high, active low, forced high, or forced low, depending on how the GPTCON bits are configured. The output goes from low to high (high to low) on the first compare match when it is active high (low). It then goes from high to low (low to high) on the second compare match if the GP timer is in the up/down counting mode, or on period match if the GP timer is in the up counting mode. The timer compare output becomes high (low) immediately when it is specified forced high (low).

For more details on the compare/PWM output behavior, refer to Section 6.5 *GP Timer Compare Operation* on page 6-34.

6.3.10 GP Timer Counting Direction

The counting directions of all three GP timers are indicated by designated bits in GPTCON during all timer operations with:

- 1 representing the up counting direction
- 0 representing the down counting direction

The input pin TMRDIR determines the direction of counting when a GP timer is in directional up/down counting mode. When TMRDIR is set high, upward counting is specified; when TMRDIR is pulled low, downward counting is specified.

6.3.11 GP Timer Clock

The source of the GP timer clock can be the internal CPU clock or the external clock input, TMRCLK. The frequency of the external clock must be less than or equal to one-fourth that of the CPU clock. GP timer 2, 3, or 2 and 3 together as a 32-bit timer, can be used with QEP circuits in the directional up/down counting mode. In this case, the QEP circuits provide both the clock and direction inputs to the timer.

A wide range of prescale factors are provided for the clock input to each GP timer.

6.3.12 32-Bit Timer

The roll-over signal of GP Timer 2 is used as clock input to GP Timer 3 when GP Timers 2 and 3 are cascaded into a 32-bit timer. When this happens, the counter of GP Timer 2 acts as the lower 16 bits of the 32-bit counter. The 32-bit timer so obtained can only operate in directional up/down counting mode (see Section 6.4 on page 6-19 for the GP timer operating modes) with external or internal clock inputs and external direction inputs. QEP circuits can also be chosen to generate the counting clock and direction for the 32-bit timer. In this case, the period registers of GP Timers 2 and 3 are cascaded to provide a 32-bit period register for the 32-bit timer, while the compare operation is based on individual compare registers and occurs individually on 16-bit compare matches. Both underflow and overflow events for the 32-bit timer are 32-bit-based.

The period, underflow, and overflow flags of GP Timer 2 are set on corresponding 32-bit matches. Period, underflow, and overflow flags of the GP Timer 3 are not relevant for 32-bit operation. Compare flags of GP Timer 2 and GP Timer 3 are set on individual compare matches.

The directional up/down operating mode for GP Timers 1 and 3 is different from that of GP Timer 2. 32-bit operation is similar to the directional up/down operating mode of GP Timers 1 and 3; that is, the 32-bit counter saturates at both period and zero counter values.

6.3.13 QEP-Based Clock Input

The quadrature encoder pulse (QEP) circuit, when selected, can generate the input clock and counting direction for GP Timers 2, 3, or 2 and 3 functioning together as a 32-bit timer in the directional up/down counting mode. This input clock cannot be scaled by the GP timer prescaler circuits (that is, the prescaler of the selected GP timer is always 1 if the QEP circuit is selected as the clock source). Furthermore, the frequency of the clock generated by QEP circuits is four times that of the frequency of each QEP input channel, because both the rising and falling edges of both QEP input channels are counted by the selected timer. The frequency of QEP input must be less than or equal to one-fourth that of the CPU clock.

6.3.14 GP Timer Synchronization

GP Timers 2 and 3 can be individually synchronized with GP Timer 1 by configuring T2CON and T3CON in the following ways:

- Start the operation of GP Timer 2 or 3 by using the same control bit in T1CON that starts the operation of GP Timer 1.
- Initialize the timer counters in GP Timer 2 or 3 with different values before synchronized operation starts.
- Specify that GP Timer 2 or 3 uses the period register of GP Timer 1 as its period register (ignoring its own period register).

This configuration provides the desired synchronization between GP timer events. Since each GP timer starts counting from its current value in the counter register, a GP timer can be programmed to start with a known delay after other GP timers. Note, however, that two writes to T1CON are required to synchronize GP Timer 1 with GP Timer 2 or GP Timers 2 and 3.

6.3.15 ADC Start by GP Timer Event

The bits in GPTCON can specify that an ADC start signal be generated on a GP timer event such as underflow, compare match, or period match. This feature provides synchronization between the GP timer event and the ADC start without any CPU intervention.

6.3.16 GP Timer in Emulation Suspend

GP timer control register bits also define the operation of GP timers during emulation suspend. These bits can be set to allow the operation of GP timers to continue when emulation interrupt occurs, making in-circuit emulation possible. They can also be set to specify that the operation of GP timer stops immediately or after completion of the current counting period when emulation interrupt occurs.

Emulation suspend occurs when the CPU clock is stopped by the emulator (for example, when the emulator encounters a break point).

6.3.17 GP Timer Interrupts

There are 12 interrupt flags in EVIFRA and EVIFRB for the three GP timers. Each GP timer can generate four interrupts upon the following events:

- Overflow: TxOFINT (x = 1, 2, or 3)
- Underflow: TxUFINT (x = 1, 2, or 3)
- Compare match: TxCINT (x = 1, 2, or 3)
- Period match: TxPINT (x = 1, 2, or 3)

A timer compare event (match) occurs when the contents of a GP timer counter is the same as that of the compare register. The corresponding compare interrupt flag is set two CPU clock cycles after the match, if the compare operation is enabled.

An overflow event occurs when the value of the timer counter reaches FFFFh; an underflow event occurs when the timer counter reaches 0000h. Similarly, a period event occurs when the value of the timer counter is the same as that of the period register. The overflow, underflow, and period interrupt flags of the timer are set two CPU clock cycles after the occurrence of each individual event.

6.4 GP Timer Counting Operation

Each GP timer has six selectable modes of operation:

- Stop/hold
- Single up counting
- Continuous up counting
- Directional up/down counting
- Single up/down counting
- Continuous up/down counting

The bit pattern in the corresponding timer control register TxCON determines the counting mode of a GP timer. The timer enabling bit, TxCON[6], enables or disables the counting operation of a timer. When the timer is disabled, the counting operation of the timer stops and the prescaler of the timer is reset to $x/1$. When the timer is enabled, the timer starts counting according to the counting mode specified by other bits of TxCON.

6.4.1 Stop/Hold Mode

In stop/hold mode, the operation of a GP timer stops and holds at its current state. The timer counter, the compare output, and the prescale counter remain unchanged in this mode.

6.4.2 Single Up Counting Mode

In single up counting mode, a GP timer counts up according to the scaled input clock until the value of the timer counter matches that of the period register. On the next rising edge of the input clock after the match, the GP timer resets to 0 and disables its counting operation by resetting the timer enable bit, TxCON[6].

The period interrupt flag of the timer is set two CPU clock cycles after the match between the timer counter and the period register. An ADC start is sent to the ADC module at the same time the flag is set if the timer's period interrupt has been programmed to start ADC by appropriate bit selections in GPTCON.

Two clock cycles after the GP timer becomes 0, the underflow interrupt flag of the timer is set. An ADC start is sent to the ADC module at the same time if the underflow interrupt flag has been programmed to start ADC by appropriate bit selections in GPTCON.

The overflow interrupt flag is set two CPU clock cycles after the value in TxCNT matches FFFFh.

The duration of the counting period of this mode is $TxPER + 1$ cycles of the scaled clock input if the timer counter is 0 at the beginning of the period.

The initial value of the GP timer can be any value between 0h and FFFFh. When the initial value is greater than the value in the period register, the timer counts up to FFFFh, resets to 0, and counts up again to finish the period as if the initial counter value was 0. When the initial value in the timer counter is the same as that of the period register, the timer sets the period interrupt flag, resets to 0, sets the underflow interrupt flag, and immediately ends the period. If the initial value of the timer is between 0 and the contents of the period register, the timer will count up to the period value and continue to finish the period as if the initial counter value were the same as that of the period register.

Once the period ends, the operation of the GP timer can be started again only by software writing to the timer enabling bit, TxCON[6].

In this operating mode, the counting direction indication bit in GPTCON is 1 for the timer, and either the external or internal CPU clock can be used as the input clock to the timer. The TMRDIR pin is ignored by the GP timer in this mode.

Figure 6–3 shows the single up counting mode of the GP timer, assuming prescale is 1.

Note that the GP timer starts counting immediately after TxCON[6] is set. This is true for every counting mode.

Figure 6–3. GP Timer Single Up Counting Mode ($TxPR = 4 - 1 = 3$)

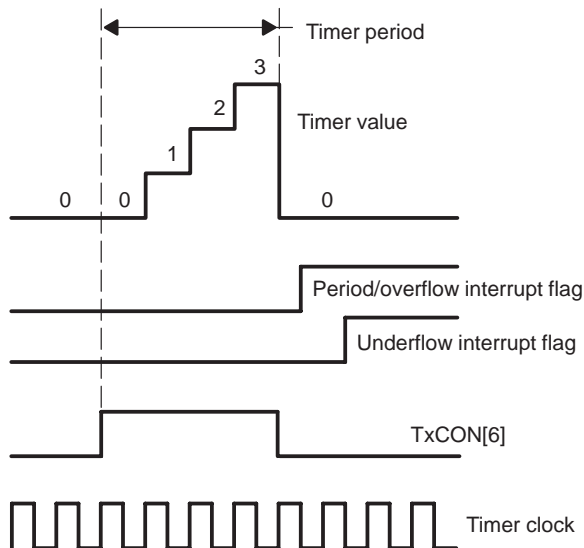

Example 6–1 shows an initialization routine for the single up counting mode for GP timer 1.

Example 6–1. Initialization Routine for Single Up Counting Mode

```

;*****
; The following section of code initializes GP Timer1 to run in single up *
; count mode. GP Timer compare function is also enabled. *
;*****
        LDPK    #232                                ; DP => EV Registers
;*****
; Configure GPTCON
;*****
        SPLK    #000000001000001b, GPTCON          ; Set GP Timer control
;
;          |||
;          FEDCBA9876543210
;
;
* bits 0-1      01:    GP Timer 1 comp output active low
* bits 2-3      00:    GP Timer 2 comp output forced low
* bits 4-5      00:    GP Timer 3 comp output forced low
* bit 6         1:     Enable GP Timer Compare outputs
* bits 7-8      00:    No GP Timer 1 event starts ADC
* bits 9-9      00:    No GP Timer 2 event starts ADC
* bits 10-11    00:    No GP Timer 3 event starts ADC
;*****
; Configure T1PER and T1CMP *
;*****
        SPLK    #05, T1PER                          ; Set GP Timer period
        SPLK    #03, T1CMP                          ; Set GP Timer compare
;*****
; Configure T1CON and start GP Timer 1 *
;*****
        SPLK    #1000100101000010b, T1CON          ; Set GP Timer 3 control
;
;          |||
;          FEDCBA9876543210
;
;
* bit 0         0:     Use own PR
* bit 1         1:     GP Timer compare enabled
* bits 2-3      00:    Load GP Timer comp register on under flow
* bits 4-5      00:    Select internal CLK
* bit 6         1:     Timer (counting operation) enabled
* bit 7         0:     Use own Timer ENABLE
* bits 8-10     001:   Prescaler = /2
* bits 11-13    001:   Single up count
* bit 14        0:     SOFT = 0
* bit 15        1:     FREE = 1

```

Note: TMS320C2x instructions are compatible with 'C2xx. The 'C2xx assembler replaces '2x instructions with equivalent '2xx instructions (ex. LDPK is replaced with LDP). Some code examples may show '2x instructions; read them as '2xx instructions. For more information, see *TMS320F/C24x DSP Controllers CPU and Instruction Set* (literature number SPRU160).

6.4.3 Continuous Up Counting Mode

The operation of the GP timer in the continuous up counting mode is the same as the single up counting mode repeated each time the GP timer is reset to 0. In this mode, the timer counts up according to the scaled input clock until the value in its counter is equal to that of the period register. It then resets to 0, and starts another counting period.

The duration of the timer period is $TxPR + 1$ cycles of the scaled clock input, except for the first period. The duration of the first period is the same if the timer counter is 0 when counting starts.

The initial value of the GP timer can be any value between 0h and FFFFh. When the initial value is greater than the value in the period register, the timer counts up to FFFFh, resets to 0, and continues the operation as if the initial value was 0. When the initial value in the timer counter is the same as that of the period register, the timer sets the period interrupt flag, resets to 0, sets the underflow interrupt flag, and then continues the operation again as if the initial value was 0. If the initial value of the timer is between 0 and the contents of the period register, the timer counts up to the period value and continues the operation as if the initial counter value is the same as that of the period register.

The period, underflow, and overflow interrupt flags, interrupts, and associated actions are generated on respective matches, the same way they are generated in the single up counting mode.

The counting direction indication bit in GPTCON is 1 for the timer in this mode, and either the external or internal CPU clock can be selected as the input clock to the timer. TMRDIR input is ignored by the GP timer in this counting mode.

The continuous up counting mode of a GP timer is particularly useful for the generation of edge-triggered or asymmetric PWM waveforms and sampling periods in many motor- and motion-control systems.

Figure 6–4 shows the continuous up counting mode of a GP timer, assuming prescale is 1.

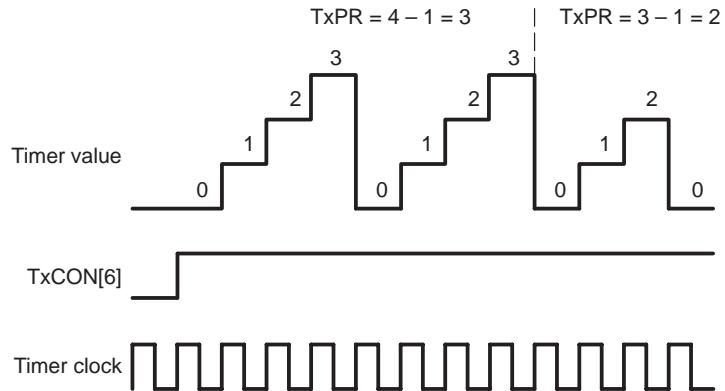
Figure 6–4. GP Timer Continuous Up Counting Mode ($TxPR = 3$ or 2)

As shown in Figure 6–4 above, no clock cycle is missed from the time the counter reaches the period register value to the time it starts another counting cycle.

Example 6–2 on page 6-24 shows an initialization routine for the continuous up counting mode for GP timer 1.

Example 6–2. Initialization Routine for Continuous Up Counting Mode

```

;*****
; The following section of code initializes GP Timer1 to run in continuous up *
; count mode. GP Timer compare function is also enabled. The counter is *
; initially loaded with FFFEH. *
;*****
        LDPK    #232                                ; DP => EV Registers
;*****
; Configure T1CON but do not start GP Timer 1 *
;*****
        SPLK    #1000000101000010b, T1CON          ; Set GP Timer 3 control
;
        | | | | | | | | | | | | | |
;
        FEDCBA9876543210
;
* bit 0      0:      Use own PR
* bit 1      1:      GP Timer compare enabled
* bits 2-3   00:     Load GP Timer comp register on under flow
* bits 4-5   00:     Select internal CLK
* bit 6      1:      Timer (counting operation) enabled
* bit 7      0:      Use own Timer ENABLE
* bits 8-10  001:    Prescaler = /2
* bits 11-13 000:    Stop and hold mode
* bit 14     0:      SOFT = 0
* bit 15     1:      FREE = 1
;*****
; Configure GPTCON
;*****
        SPLK    #0000000001101010b, GPTCON        ; Set GP Timer control
;
        | | | | | | | | | | | | | |
;
        FEDCBA9876543210
;
* bits 0-1   10:     GP Timer 1 comp output active high
* bits 2-3   10:     GP Timer 2 comp output active high
* bits 4-5   10:     GP Timer 3 comp output active high
* bit 6      1:      Enable GP Timer Compare outputs
* bits 7-8   00:     No GP Timer 1 event starts ADC
* bits 9-10  00:     No GP Timer 2 event starts ADC
* bits 11-12 00:     No GP Timer 3 event starts ADC
;*****
; Configure T1PR T1CMPR and T1CNT *
;*****
        SPLK    #05, T1PR                            ; Set GP Timer period
        SPLK    #03, T1CMPR                          ; Set GP Timer compare
        SPLK    #0FFFEh, T1CNT                       ; Set GP Timer counter

```

Example 6–2. Initialization Routine for Continuous Up Counting Mode (Continued)

```

;*****
; Start GP Timer
;*****
        SPLK    #1001000101000010b, T1CON        ; Set GP Timer 3 control
;
;          |||||
;          FEDCBA9876543210
;
* bit 0          0:    Use own PR
* bit 1          1:    GP Timer compare enabled
* bits 2-3      00:    Load GP Timer comp register on under flow
* bits 4-5      00:    Select internal CLK
* bit 6         1:    Timer (counting operation) enabled
* bit 7         0:    Use own Timer ENABLE
* bits 8-10     001:   Prescaler = /2
* bits 11-13    010:   Continuous up count
* bit 14        0:    SOFT = 0
* bit 15        1:    FREE = 1

```

6.4.4 Directional Up/Down Counting Mode of GP Timers 1 and 3

In the directional up/down counting mode, GP timers 1 and 3 count up or down according to the scaled clock and TMRDIR inputs. When the TMRDIR pin is held high, each timer counts up until its value reaches that of the period register or FFFFh. When TMRDIR is held high and the timer value equals that of its period register or FFFFh, the timer holds at that value. When TMRDIR is held low, the timer counts down until its value becomes 0. When TMRDIR is held low and the value of the timer is 0, the timer holds at 0.

The initial value of the timer can be any value between 0000h and FFFFh. When the initial value of the timer counter is greater than that of the period register, the timer counts up to FFFFh and holds at FFFFh if TMRDIR is held high. It counts down to the value of the period register if TMRDIR is held low and continues as if the initial value of the timer is equal to that of the period register. If the initial value of the timer is equal to that of the period register, the timer holds at that value if TMRDIR is held high and counts down from the initial/register value if TMRDIR is held low.

The period, underflow, and overflow interrupt flags, interrupts, and associated actions are generated on respective events in the same way that they are generated in single up counting mode.

The latency between a change of TMRDIR and a change of counting direction is two CPU clock cycles after the end of the current timer count.

The direction of a timer's counting in this mode is indicated by the corresponding direction-indication bit in GPTCON: 1 means counting up; 0 means counting down. Either the external or Internal CPU clock can be used as the input clock for the timer in this mode.

Figure 6–5 below illustrates the counting operation of the directional up/down counting mode for GP Timers 1 and 3.

Figure 6–5. Directional Up/Down Counting Mode of GP Timers 1 and 3 With Prescale Factor 1 and TxPR = 3

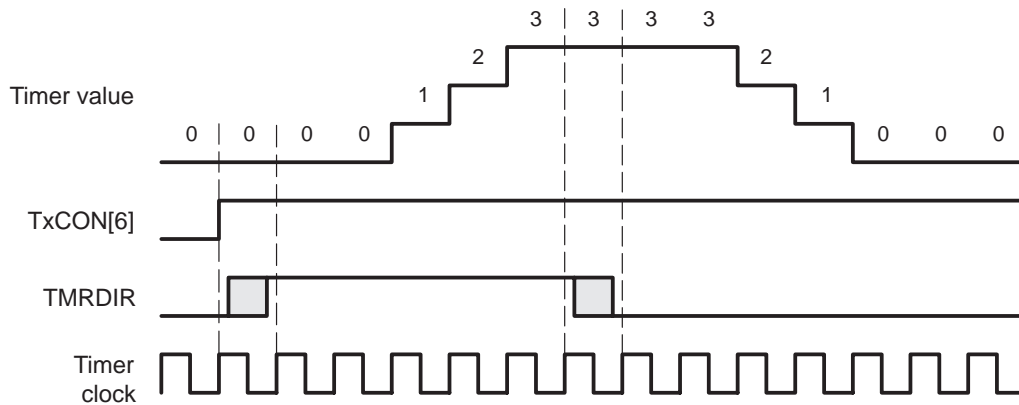

6.4.5 Directional Up/Down Counting Mode of GP Timer 2

The directional up/down counting mode of GP Timer 2 is different from the directional up/down counting mode of GP Timers 1 and 3. GP Timer 2, when in directional up/down counting mode, counts through period and roll over on overflow and underflow. This mode of operation can be used to time and count the occurrence of external events in motion/motor control and power electronics applications.

Note:

No transition occurs on the compare outputs associated with the compare modules (including GP timer compare, full compare, and simple compare) that use the GP timer in this mode as their time base.

Example 6–3 on page 6-27 shows an initialization routine for the directional up/down counting mode for GP Timer 1.

When the QEP circuit is selected as the clock source for a GP timer, the timer must be put in the up/down mode. The operation of a QEP circuit is described in Section 6.13 on page 6-91.

**Example 6–3. Initialization Routine for Directional Up/down Counting Mode
Using An External Clock**

```

;*****
; The following section of code initializes GP Timer1 to run in directional *
; up/down counting mode. GP Timer compare function is also enabled, however *
; that will have no effect on compare output pin. *
;*****
        LDPK    #232                                ; DP => EV Registers
;*****
; Configure GPTCON
;*****
        SPLK    #000000001101010b, GPTCON          ; Set GP Timer control
;
;          ||| ||| ||| ||| ||| ||| ||| |||
;          FEDCBA9876543210
;
* bits 0-1      10:    GP Timer 1 comp output active high
* bits 2-3      10:    GP Timer 2 comp output active high
* bits 4-5      10:    GP Timer 3 comp output active high
* bit 6         1:     Enable GP Timer Compare outputs
* bits 7-8      00:    No GP Timer 1 event starts ADC
* bits 9-10     00:    No GP Timer 2 event starts ADC
* bits 11-12    00:    No GP Timer 3 event starts ADC
;*****
; Configure T1PER and T1CMP *
;*****
        SPLK    #05, T1PER                          ; Set GP Timer period
        SPLK    #03, T1CMP                          ; Set GP Timer compare
;*****
; Start GP Timer *
;*****
        SPLK    #1001100001010010b, T1CON          ; Set GP Timer 3 control
;
;          ||| ||| ||| ||| ||| ||| ||| |||
;          FEDCBA9876543210
;
* bit 0         0:     Use own PR
* bit 1         1:     GP Timer compare enabled
* bits 2-3      00:    Load GP Timer comp register on under flow
* bits 4-5      10:    Select internal CLK
* bit 6         1:     Timer (counting operation) enabled
* bit 7         0:     Use own Timer ENABLE
* bits 8-10     000:   Prescaler = /1
* bits 11-13    011:   Directional up-down count
* bit 14        0:     SOFT = 0
* bit 15        1:     FREE = 1

```

6.4.6 Single Up/Down Counting Mode

In single up/down counting mode, the GP timer counts up according to the scaled clock input to the value in its period register. It then changes its counting direction and counts down until it reaches 0. When the timer reaches 0, it resets TxCON[6] and its prescale counter, stops, and holds at its current state.

The period of a GP timer in this mode is $2 \times (\text{TxPR})$ cycles of the scaled clock input if the initial value of the timer is 0.

The initial value of the timer counter can be any value between 0h and FFFFh. If the initial timer value is greater than that of the period register, the timer counts up to FFFFh, resets to 0, and continues as if the initial value of the timer was 0. If the initial value of the timer is the same as that of the period register, the timer counts down to 0 and ends the period there. If the initial value of the timer is between 0 and the contents of the period register, the timer counts up to the period value and continues to finish the period as if the initial counter value was the same as that of the period register.

The period, underflow, and overflow interrupt flags, interrupts, and associated actions are generated on respective events in the same way that they are generated in single up counting mode. Note, however, that a period event happens when a match between the timer counter and the period register is made, which is in the middle of a counting period.

Once the operation of a GP timer in this mode has ended, the operation can be started again only by software writing a 1 to TxCON[6]. The direction indication bit in GPTCON is 1 when the counting direction is up, and 0 when the counting direction is down. Either the external clock or the internal CPU clock can be selected as the clock input to the timer. TMRDIR input is ignored by a GP timer in this mode.

Figure 6–6 shows the single up/down counting mode of a GP timer. Example 6–4 shows an initialization routine for GP Timer 1 in the single up/down counting mode.

Figure 6–6. GP Timer Single Up/down Counting Mode (TxPR = 3)

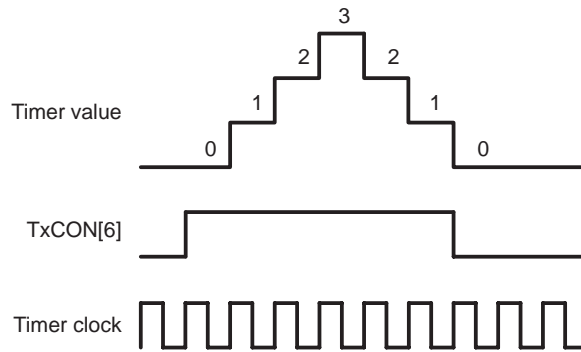

Example 6–4. Initialization Routine for Single Up/Down Counting Mode

```

;*****
; The following section of code initializes GP Timer1 to run in single Up *
; count mode. GP Timer compare function is also enabled. *
;*****
        LDPK    #232                                ; DP => EV Registers
;*****
; Configure GPTCON
;*****
        SPLK    #000000001000001b, GPTCON          ; Set GP Timer control
;
        | | | | | | | | | | | | | |
        FEDCBA9876543210
;
* bits 0-1      01:    GP Timer 1 comp output active low
* bits 2-3      00:    GP Timer 2 comp output forced low
* bits 4-5      00:    GP Timer 3 comp output forced low
* bit 6         1:     Enable GP Timer Compare outputs
* bits 7-8      00:    No GP Timer 1 event starts ADC
* bits 9-9      00:    No GP Timer 2 event starts ADC
* bits 10-11    00:    No GP Timer 3 event starts ADC
;*****
; Configure T1PER and T1CMP *
;*****
        SPLK    #05, T1PER                          ; Set GP Timer period
        SPLK    #03, T1CMP                          ; Set GP Timer compare
;*****
; Configure T1CON and start GP Timer 1 *
;*****
        SPLK    #1000100101000010b, T1CON          ; Set GP Timer 3 control
;
        | | | | | | | | | | | | | |
        FEDCBA9876543210
;
* bit 0         0:     Use own PR
* bit 1         1:     GP Timer compare enabled
* bits 2-3      00:    Load GP Timer comp register on underflow
* bits 4-5      00:    Select internal CLK
* bit 6         1:     Timer (counting operation) enabled
* bit 7         0:     Use own Timer ENABLE
* bits 8-10     001:   Prescaler = /2
* bits 11-13    001:   Single up count
* bit 14        0:     SOFT = 0
* bit 15        1:     FREE = 1

```

6.4.7 Continuous Up/Down Counting Mode

The continuous up/down counting mode is the same as the single up/down counting mode repeated each time the timer is reset to 0. Once the continuous up/down counting mode is started, no user software or hardware intervention is required to repeat the counting period.

The period of a timer in this mode is $2 \times (TxPR)$ cycles of the scaled clock input, except for the first period. The duration of the first counting period is the same if the timer counter is 0 when counting starts.

The initial value of a GP timer counter can be any value between 0h and FFFFh. When the initial value is greater than that of the period register, the timer counts up to FFFFh, resets to 0, and continues the operation as if the initial value is 0. When the initial value in the timer counter is the same as that of the period register, the timer counts down to 0 and continues as if the initial value is 0. If the initial value of the timer is between 0 and the contents of the period register, the timer counts up to the period value and continues to finish the period as if the initial counter value is the same as that of the period register.

The period, underflow, and overflow interrupt flags, interrupts, and associated actions are generated on respective events in the same way that they are generated in single up counting mode.

The counting direction indication bit in GPTCON is 1 for a timer in the continuous up/down counting mode when the timer counts up and 0 when the timer counts down. Either the external or internal CPU clock can be selected as the input clock. TMRDIR input is ignored by a timer in this mode.

The continuous up/down counting mode is particularly useful in generating centered or symmetric pulse width modulation (PWM) waveforms found in a broad range of motor/motion-control and power-electronics applications.

Figure 6–7 on page 6-32 shows the continuous up/down counting mode of a GP timer, and Example 6–5 on page 6-33 shows an initialization routine for the continuous up/down counting mode.

Figure 6–7. GP Timer Continuous Up/Down Counting Mode (TxPR = 3 or 2)

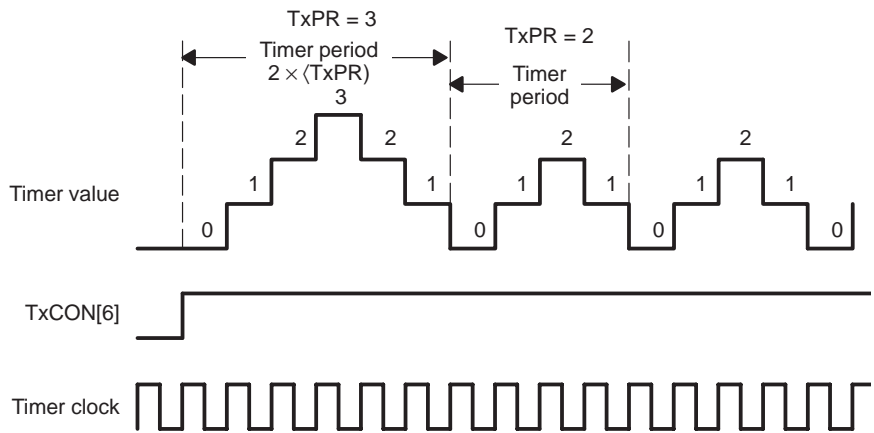

Example 6–5. Initialization Routine for the Continuous Up/Down Counting Mode

```

;*****
; The following section of code initializes GP Timer1 to run in continuous Up/down *
; count mode. GP Timer compare function is also enabled. *
;*****
                LDPK    #232                                ; DP => EV Registers
;*****
; Configure GPTCON
;*****
                SPLK    #000000000111111b, GPTCON          ; Set GP Timer control
;
                |||||||||||||||
                FEDCBA9876543210
;
* bits 0-1      01:    GP Timer 1 comp output forced high
* bits 2-3      00:    GP Timer 2 comp output forced high
* bits 4-5      00:    GP Timer 3 comp output forced high
* bit 6         1:     Enable GP Timer Compare outputs
* bits 7-8      00:    No GP Timer 1 event starts ADC
* bits 9-9      00:    No GP Timer 2 event starts ADC
* bits 10-11    00:    No GP Timer 3 event starts ADC
;*****
; Configure T1PER and T1CMP *
;*****
                SPLK    #05, T1PER                          ; Set GP Timer period
                SPLK    #03, T1CMP                          ; Set GP Timer compare
;*****
; Configure T1CON and start GP Timer 1 *
;*****
                SPLK    #1010100001000000b, T1CON          ; Set GP Timer 3 control
;
                |||||||||||||||
                FEDCBA9876543210
;
* bit 0         0:     Use own PR
* bit 1         0:     GP Timer compare disabled
* bits 2-3      00:    Load GP Timer comp register on underflow
* bits 4-5      00:    Select internal CLK
* bit 6         1:     Timer (counting operation) enabled
* bit 7         0:     Use own Timer ENABLE
* bits 8-10     000:   Prescaler = /1
* bits 11-13    010:   Continuous up/down count
* bit 14        0:     SOFT = 0
* bit 15        1:     FREE = 1

```

6.5 GP Timer Compare Operation

Each GP timer has an associated compare register, TxCMPR, and a compare/PWM output pin, TxPWM/TxCMP. The value of a GP timer counter is constantly compared to that of its associated compare register. A compare match occurs when the value of the timer counter is the same as that of the compare register. The compare operation is enabled by setting TxCON[1] to 1. When the compare operation is enabled, the following happens on a compare match:

- The compare interrupt flag of the timer is set two CPU clock cycles after the match.
- If the GP timer is not in the directional up/down counting mode, a transition occurs on the associated compare/PWM output according to the bit configuration in GPTCON, one CPU clock cycle after the match.
- If the compare interrupt flag has been selected by the appropriate GPTCON bits to start ADC, an ADC start signal is generated at the same time the compare interrupt flag is set.

If the compare operation of the GP timer is disabled, the compare/PWM output is put in the high impedance state, and none of the above events occur.

6.5.1 Compare/PWM Transition

A transition on the compare/PWM output is controlled by a waveform generator (both symmetric and asymmetric) and the associated output logic, and depends on the following:

- The bit definition in GPTCON
- The counting mode of the timer
- The counting direction when in single or continuous up/down counting mode

6.5.2 Asymmetric/Symmetric Waveform Generator

The asymmetric/symmetric waveform generator produces an asymmetric or symmetric compare/PWM waveform based on the counting mode of the GP timer.

6.5.3 Asymmetric Waveform Generation

An asymmetric waveform, as shown in Figure 6–8 on page 6-35, is generated when the GP timer is in the single or continuous up counting mode. When the GP timer is in either of these two modes, the output of the waveform generator changes as follows:

- Changes to 0 before the counting operation starts
- Remains unchanged until the compare match occurs
- Toggles on compare match
- Remains unchanged until the end of the period
- Resets to 0 at the end of a period on period match if the new compare value for the following period is not 0

The output is 1 for the whole period if the compare value is 0 at the beginning of the period. The output does not reset to 0 if the new compare value for the following period is 0. This is important because it allows the generation of PWM pulses of 0% to 100% duty cycle without glitches. The output is 0 for the whole period if the compare value is greater than the value in the period register. The output is 1 for one cycle of the scaled clock input if the compare value is the same as that of the period register.

One characteristic of an asymmetric compare/PWM waveform is that a change in the value of the compare register affects only one side of the compare/PWM pulse.

Figure 6–8. GP Timer Compare/PWM Output in Up Counting Mode

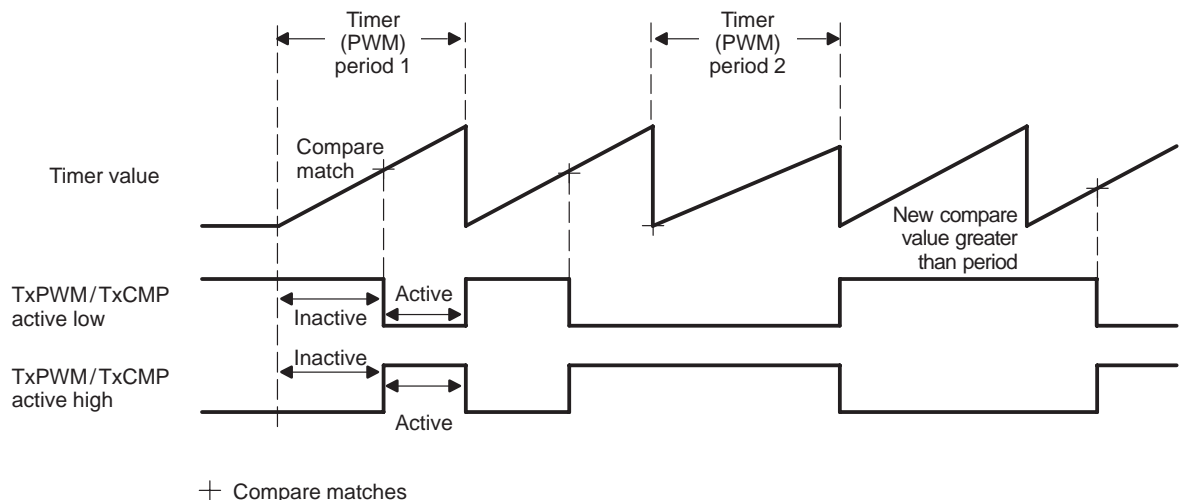

6.5.4 Symmetric Waveform Generation

A symmetric waveform, as shown in Figure 6–9, is generated when the GP timer is in the single or continuous up/down counting mode. When the GP timer is in either of these two modes, the state of the output of the waveform generator changes as follows:

- Changes to 0 before the counting operation starts
- Remains unchanged until first compare match occurs
- Toggles on the first compare match
- Remains unchanged until the the second compare match occurs
- Toggles on the second compare match
- Remains unchanged until the end of the period
- Resets to 0 at the end of the period if there is no second compare match and the new compare value for the following period is not 0

The output is set to 1 at the beginning of a period and remains 1 until the second compare match if the compare value is 0. After the first transition from 0 to 1, the output remains 1 until the end of the period if the compare value is 0 for the rest of the period. When this happens, the output does not reset to 0 if the compare value for the following period is still 0. The output is again set to 1 at the beginning of a period and the process repeats itself to assure the generation of PWM pulses of 0% to 100% duty cycle without any glitches. The first transition does not occur if the compare value is greater than or equal to that of the period register for the first half of the period. The output still toggles when a compare match occurs in the second half of the period. This error in output transition (often the result of a calculation error in the application routine) is corrected at the end of the period because the output resets to 0, unless the new compare value for the following period is 0. If the latter happens, the output remains 1 (does not reset to 0), which leaves it in the correct state.

Note:

The output logic determines the polarity for all output pins.

Figure 6–9. GP Timer Compare/PWM Output in Up/down Counting Modes

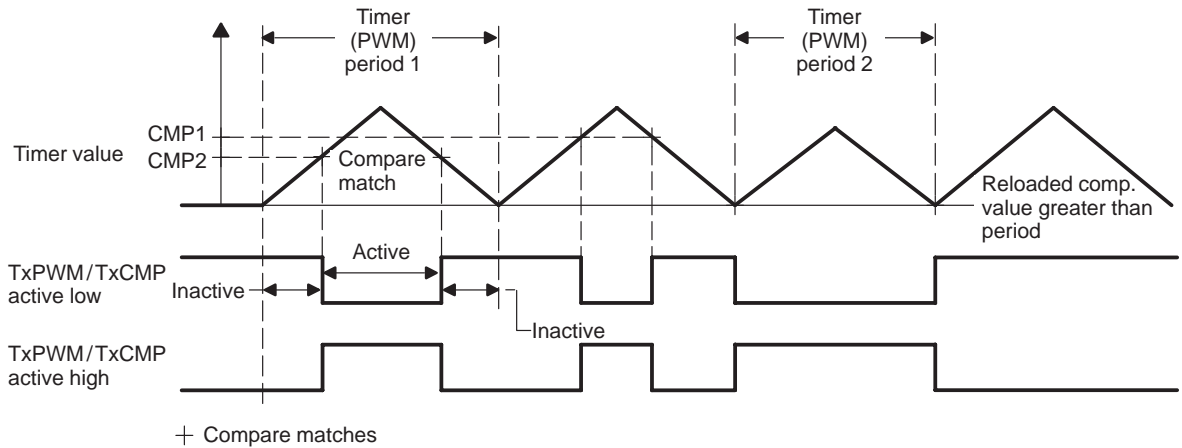

6.5.5 Output Logic

The output logic further conditions the output of the waveform generator to form the ultimate compare/PWM output to control the turn-on and turn-off of various power devices. The compare/PWM output can be specified *active high*, *active low*, *forced low*, or *forced high* by proper configuration of GPTCON bits. Setting active means setting high for *active high* and setting low for *active low*. Setting inactive means the opposite.

The polarity of the compare/PWM output is the same as that of the output of the associated asymmetric/symmetric waveform generator when the compare/PWM output is specified active high.

The polarity of the compare/PWM output is the opposite of that of the output of the associated asymmetric/symmetric waveform generator when the compare/PWM output is specified active low.

The compare/PWM output is set to 1 (or 0) immediately after the corresponding bits in GPTCON are set if the bit pattern specifies that the state of compare/PWM output is forced high (or low).

Table 6–6 describes the GP timer compare/PWM output transitions occurring in a regular period of single up counting or continuous up counting mode. Table 6–7 describes the GP timer compare/PWM output transitions for single up/down counting and continuous up/down counting modes.

The asymmetric/symmetric waveform generation, based on the timer counting mode and the output logic, are also applicable to both full and simple compare units.

Table 6–6. GP Timer Compare/PWM Output in Single Up and Continuous Up Counting Modes

Time in a Period	State of Compare Output
Before compare match	Inactive
On compare match	Set active
On period match	Set inactive

Table 6–7. GP Timer Compare/PWM Output in Single Up/Down and Continuous Up/Down Counting Modes

Time in a Period	State of Compare Output
Before first compare match	Inactive
On first compare match	Set active
On second compare match	Set inactive
After second compare match	Inactive

All GP timer compare/PWM outputs are put in the high impedance state when any of the following events occur:

- GPTCON[6] is set to 0 by software.
- PDPINT is pulled low and is unmasked.
- Any reset event occurs.

Additionally, the compare/PWM output of a GP timer is put in high impedance when the compare operation is disabled for the GP timer.

6.5.6 Compare Output in Directional Up/Down Counting Mode

When a GP timer is in the directional up/down counting mode, no transition occurs on its compare output. Similarly, no transition occurs on the compare outputs associated with full compare units when GP timer 1 is in the directional up/down counting mode. No transition occurs on the compare outputs associated with simple compare units when the GP timer selected as the time base for simple compare units is in the directional up/down counting mode. The setting of compare interrupt flags and the generation of compare interrupt requests, however, do not depend on the counting mode of the GP timer.

6.5.7 Active/Inactive Time Calculation

For up counting modes, the value in the compare register represents the elapsed time between the beginning of a period and the occurrence of the first compare match; that is, the length of the inactive phase. This elapsed time is equal to the period of the scaled input clock multiplied by the value of TxCMPR. Therefore, the length of the active phase (the output pulse width) is given by $TxPR - TxCMPR + 1$ cycle of the scaled input clock.

For up/down counting modes, the compare register can have a different value for counting down than for counting up. The length of the active phase, that is, the output pulse width for up/down counting modes, is thus given by $TxPR - TxCMPR_{up} + TxPR - TxCMPR_{dn}$ cycles of the scaled input clock, where $TxCMPR_{up}$ is the compare value on the way up and $TxCMPR_{dn}$ is the compare value on the way down.

When the value in TxCMPR is 0, the GP timer compare output is active for the whole period if the timer is in the up counting mode. For up/down counting modes, the compare output is active at the beginning of the period if $TxCMPR_{up}$ is 0. The output remains active until the end of the period if $TxCMPR_{dn}$ is also 0.

The length of the active phase (the output pulse width) is 0 when the value of TxCMPR is greater than that of TxPR for up counting modes. For up/down counting, the first transition is lost when $TxCMPR_{up}$ is greater than or equal to TxPR. Similarly, the second transition is lost when $TxCMPR_{dn}$ is greater than or equal to TxPR. The GP timer compare output is inactive for the entire period if both $TxCMPR_{up}$ and $TxCMPR_{dn}$ are greater than or equal to TxPR for up/down counting modes.

Figure 6–8 on page 6-35 shows the compare operation of a GP timer in the up counting mode. Figure 6–9 on page 6-37 shows the compare operation of a GP timer in the up/down counting mode.

6.6 GP Timer Control Registers (TxCON and GPTCON)

The addresses of GP timer registers are given in Table 6.2 on page 6-8. Figure 6–10 below shows the bit definition of GP timer control register TxCON, and Figure 6–11 on page 6-42 shows the bit definition of GP timer control register GPTCON.

GP Timer Control Register (TxCON; x = 1, 2, and 3)

Figure 6–10. GP Timer Control Register (TxCON; x = 1, 2, and 3) — Addresses 7404h, 7408h, and 740Ch

15	14	13	12	11	10	9	8
Free	Soft	TMODE2	TMODE1	TMODE0	TPS2	TPS1	TPS0
RW-0	RW-0	RW-0	RW-0	RW-0	RW-0	RW-0	RW-0
7	6	5	4	3	2	1	0
TSWT1	TENABLE	TCLKS1	TCLKS0	TCLD1	TCLD0	TECMPR	SELT1PR
RW-0	RW-0	RW-0	RW-0	RW-0	RW-0	RW-0	RW-0

Note: R = read access, W = write access, -0 = value after reset

Bits 15–14 Free, Soft. Emulation control bits

- 00 = Stop immediately on emulation suspend
- 01 = Stop after current timer period is completed on emulation suspend
- 10 = Operation is not affected by emulation suspend
- 11 = Operation is not affected by emulation suspend

Bits 13–11 TMODE2–TMODE0. Count mode selection

- 000 = Stop/hold
- 001 = Single up counting mode
- 010 = Continuous up counting mode
- 011 = Directional up/down counting mode
- 100 = Single up/down counting mode
- 101 = Continuous up/down counting mode
- 110 = Reserved. Result is unpredictable
- 111 = Reserved. Result is unpredictable

- Bits 10–8** **TPS2–TPS0.** Input clock prescaler
- 000 = x/1
 - 001 = x/2
 - 010 = x/4
 - 011 = x/8
 - 100 = x/16
 - 101 = x/32
 - 110 = x/64
 - 111 = x/128
- x = CPU clock frequency
- Bit 7** **TSWT1.** (GP timer start with GP timer 1). Start timer with GP timer 1 timer enable bit. This bit is reserved in T1CON.
- 0 = Use own TENABLE bit
 - 1 = Use TENABLE bit of T1CON to enable and disable operation ignoring own TENABLE bit
- Bit 6** **TENABLE.** Timer enable. In single up counting and single up/down counting modes, this bit is cleared to 0 by the timer after it completes a period of operation.
- 0 = Disable timer operation; that is, put the timer in hold and reset the prescaler counter
 - 1 = Enable timer operations
- Bits 5–4** **TCLKS1, TCLKS0.** Clock source select
- 00 = Internal
 - 01 = External
 - 10 = Rollover from GP timer 2 (only applicable to T3CON when GP Timers 2 and 3 are cascaded into a 32-bit timer; reserved in T1CON and T2CON; ILLEGAL if SELT1PR=1.)
 - 11 = Quadrature encoder pulse circuit (only applicable to T2CON and T3CON; reserved in T1CON; ILLEGAL if SELT1PR is 1)
- ILLEGAL means result is unpredictable.
- Bits 3–2** **TCLD1, TCLD0.** Timer compare (active) register reload condition
- 00 = When counter is 0
 - 01 = When counter value is 0 or equals period register value

- 10 = Immediately
- 11 = Reserved

Bit 1 **TECMPR.** Timer compare enable

- 0 = Disable timer compare operation
- 1 = Enable timer compare operation

Bit 0 **SELT1PR.** Period register select. This bit is reserved in T1CON.

- 0 = Use own period register
- 1 = Use T1PR as period register ignoring own period register

Note: Synchronization of the GP Timers

Two consecutive writes to T1CON are required to ensure the synchronization of the GP timers when T1CON[6] is used to enable GP timer 2 or 3:

- 1) Configure all other bits with T1CON[6] set to 0.
- 2) Enable GP timer 1 and, thus, GP timer 2 or GP timers 2 and 3, by setting T1CON[6] to 1.

GP Timer Control Register (GPTCON)

Figure 6–11. GP Timer Control Register (GPTCON) — Address 7400h

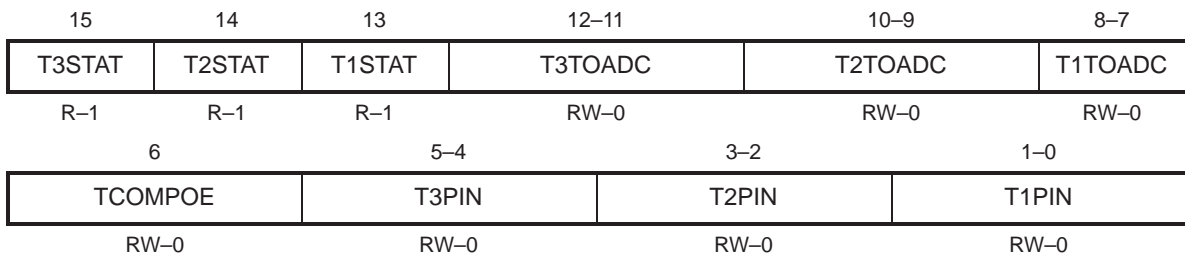

Note: R = read access, W = write access, –n = value after reset

Bit 15 **T3STAT.** GP timer 3 status. Read only

- 0 = Count down
- 1 = Count up

Bit 14 **T2STAT.** GP timer 2 status. Read only

- 0 = Count down
- 1 = Count up

- Bit 13** **T1STAT.** GP timer 1 status. Read only
- 0 = Count down
 - 1 = Count up
- Bits 12–11** **T3TOADC.** Start ADC by GP timer 3 event
- 00 = No event starts ADC
 - 01 = Setting of underflow interrupt flag
 - 10 = Setting of period interrupt flag
 - 11 = Setting of compare interrupt flag
- Bits 10–9** **T2TOADC.** Start ADC by GP timer 2 event
- 00 = No event starts ADC
 - 01 = Setting of underflow interrupt flag. Starts ADC
 - 10 = Setting of period interrupt flag. Starts ADC
 - 11 = Setting of compare interrupt flag. Starts ADC
- Bits 8–7** **T1TOADC.** Start ADC by GP timer 1 event
- 00 = No event starts ADC
 - 01 = Setting of underflow interrupt flag
 - 10 = Setting of period interrupt flag
 - 11 = Setting of compare interrupt flag
- Bit 6** **TCOMPOE.** Compare output enable. Active PDPINT writes 0 to this bit.
- 0 = Disable all three GP timer compare outputs (all three compare outputs are put in the high-impedance state)
 - 1 = Enable all three GP timer compare outputs
- Bits 5–4** **T3PIN.** Polarity of GP timer 3 compare output
- 00 = Forced low
 - 01 = Active low
 - 10 = Active high
 - 11 = Forced high
- Bits 3–2** **T2PIN.** Polarity of GP timer 2 compare output
- 00 = Forced low
 - 01 = Active low
 - 10 = Active high
 - 11 = Forced high

Bits 1–0 **T1PIN.** Polarity of GP timer 1 compare output

- 00 = Forced low
- 01 = Active low
- 10 = Active high
- 11 = Forced high

6.7 Generation of Compare and PWM Outputs Using GP Timers

Each GP timer can be used independently to provide a compare or PWM output channel. Thus, up to three compare or PWM outputs may be generated by the GP timers.

6.7.1 Generation of Compare Output

To generate a compare output, select an appropriate GP timer operating mode. Then perform the following:

- Set up TxCMPR according to when the compare event will happen.
- Set up GPTCON so that the desired transition on compare output takes place on compare match.
- Load TxPR with the desired period value, if needed.
- Load TxCNT with the desired initial counter value, if needed.
- Set up TxCON to specify the counting mode and clock source and start the operation.

6.7.2 Generation of PWM Output

To generate a PWM output with a GP timer, select the continuous up counting or up/down counting mode. Edge-triggered or asymmetric PWM waveforms are generated when the continuous up counting mode is selected. Centered or symmetric PWM waveforms are generated when the continuous up/down counting mode is selected. To set up a GP timer for the PWM operation, perform the following:

- Set up TxPR according to the desired PWM (carrier) period.
- Set up TxCON to specify the counting mode and clock source and start the operation.
- Load TxCMPR with values corresponding to the on-line calculated widths (duty cycles) of PWM pulses.

When the continuous up counting mode is selected to generate asymmetric PWM waveforms, the period value is obtained by dividing the desired PWM period by the period of the GP timer input clock and subtracting 1 from the resulting number. When the continuous up/down counting mode is selected to generate symmetric PWM waveforms, the period value is obtained by dividing the desired PWM period by 2 times the period of the GP timer input clock

The GP timer can be initialized the same way as in the previous example. During run time, the GP timer compare register is constantly updated with newly determined compare values corresponding to the newly determined duty cycles.

Figure 6–8 on page 6-35 and Figure 6–9 on page 6-37 are examples of asymmetric and symmetric PWM waveforms that can be generated by a GP timer.

6.7.3 GP Timer Reset

When any RESET event occurs, the following happens:

- All GP timer register bits, except for the counting-direction indication bits in GPTCON, are reset to 0; thus, the operation of all GP timers is disabled. The counting-direction indication bits are all set to 1.
- All timer interrupt flags are reset to 0.
- All timer interrupt mask bits are reset to 0; thus, all GP timer interrupts are masked.
- All GP timer compare outputs are put in the high-impedance state.

6.8 Compare Units

There are three full compare units (full compare units 1, 2, and 3) and three simple compare units (simple compare units 1, 2, and 3) in the EV module. Each full compare unit has two associated compare/PWM outputs. Each simple compare unit has one associated compare/PWM output. The time base for full compare units is provided by GP timer 1. The time base for simple compare units can be GP timer 1 or 2.

6.8.1 Simple Compare Units

The three simple compare units include:

- Three 16-bit compare registers (SCMPRx, x = 1, 2, 3), each with an associated shadow register (R/W)
- One compare control register (COMCON) shared with full compare units (R/W)
- One 16-bit action control register (SACTR) with an associated shadow register (R/W)
- Three asymmetric/symmetric waveform generators
- Three compare/PWM (3-state) outputs (PWM_y/CMP_y, y = 7, 8, 9), one for each simple compare unit, with programmable polarity
- Compare and interrupt logic

The operation of the three simple compare units is the same as the GP timer compare operation except that:

- The time base for the simple compare units can be GP timer 1 or 2.
- The appropriate bits in COMCON control the following:
 - Enabling and disabling of the simple compare operation and outputs
 - The condition when (active) simple compare registers are updated
 - Selection of the time base for simple compare operation.
- The behavior of compare outputs of simple compare units is individually defined by the corresponding bits in the simple compare action control register SACTR.

Figure 6–12 on page 6-48 shows a block diagram for simple compare units.

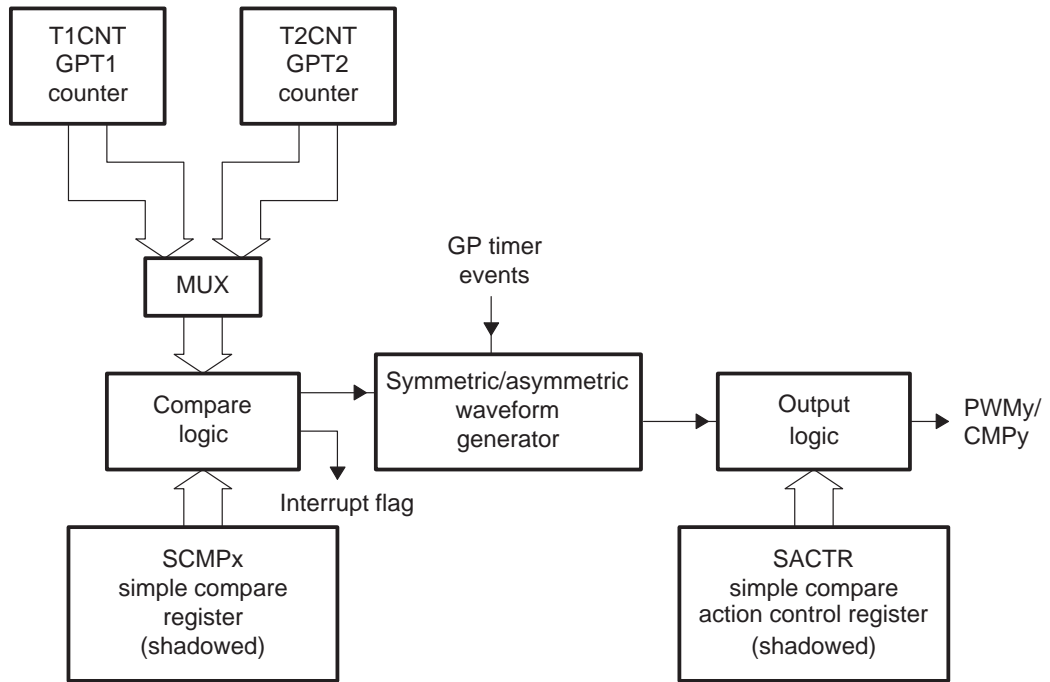
Figure 6–12. Simple Compare Unit Block Diagram ($x = 1, 2, \text{ or } 3; y = 7, 8, \text{ or } 9$)

The timing of simple compare outputs is the same as that of the GP timer compare outputs. There is an interrupt flag for each simple compare unit and the setting of these flags is the same as in the GP timer compare operation.

6.8.2 Full Compare Units

The three full compare units include:

- Three 16-bit compare registers (CMPRx, $x = 1, 2, 3$), each with an associated shadow register (R/W)
- One 16-bit read/write compare control register (COMCON)
- One 16-bit action control register (ACTR), with an associated read/write-shadow register (R/W)
- Six compare/PWM (3-state) output pins (PWM y /CMP y , $y = 1, 2, 3, 4, 5, 6$)
- Control and interrupt logic

A functional block diagram of the full compare unit is shown in Figure 6–13.

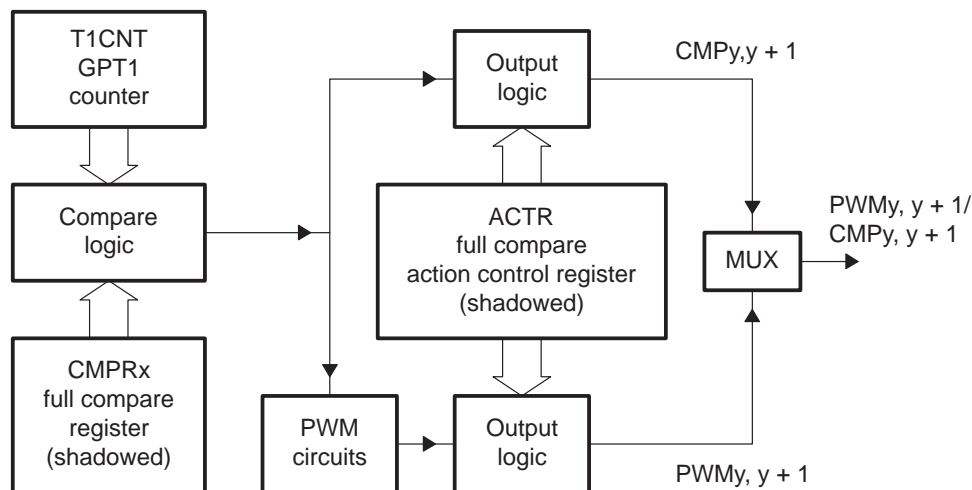
Figure 6–13. Full Compare Unit Block Diagram ($x = 1, 2, 3; y = 1, 3, 5$)

The time base for full compare units and the associated PWM circuits is provided by GP timer 1. This timer can be in any of its six counting modes when the compare operation is enabled. However, no transition happens on compare outputs when GP timer 1 is in the directional up/down counting mode.

6.8.3 Full Compare Inputs/Outputs

The inputs to a full compare unit include:

- Control signals from control registers
- GP timer 1 (T1CNT) and its underflow and period match signals
- The RESET signal

The output of a full compare unit is a compare match signal. If the compare operation is enabled, this match signal sets the interrupt flag and causes transitions on the two output pins associated with the full compare unit. When full compare operation is disabled, all full compare/PWM outputs are put in the high-impedance state.

6.8.4 Full Compare Operation Modes

The operating mode of full compare units is determined by bits in COMCON. These bits determine:

- Whether full compare operation is enabled
- Whether full compare outputs are enabled
- The condition on which full compare registers are updated with values in their shadow registers

- The condition on which the full action control register is updated with the value in its shadow register
- Whether the space vector PWM mode is enabled
- Whether each full compare unit is in the compare or PWM mode

The three full compare units can operate in either of two operating modes: compare or PWM.

6.8.5 Compare Mode

When the compare mode is selected and full compare is enabled for a full compare unit, the value of the GP timer 1 counter is continuously compared with that of the compare register and the following occurs on a compare match:

- A transition appears on the two compare/PWM outputs of the full compare unit.
- The compare interrupt of the full compare unit is set.

None of the above occurs if the full compare operation is disabled.

These bits can individually specify each output to hold, reset (go low), set (go high), or toggle on a compare match. The timing of output transitions and setting of interrupt flags is the same as in the GP timer compare operation. The outputs of full compare units in compare mode are subject to modification by the output logic.

6.8.6 PWM Mode

Each full compare unit can be put individually into the PWM mode. The operation of full compare units in this mode is similar to the GP timer compare operation except that the full compare units are controlled by different control registers and are subject to modification by dead-band units and space vector PWM logic. The PWM mode of operation is further described in the following sections.

6.8.7 Register Setup for Full Compare Operation

The register setup for full compare operation requires:

- Setting up T1PR
- Setting up ACTR
- Initializing CMPRx
- Setting up COMCON
- Setting up T1CON

Note that in many cases, COMCON requires two writes to ensure the correct polarity of PWM outputs.

6.8.8 Compare Unit Registers

The addresses of registers associated with full and simple compare units and associated PWM circuits are shown in Table 6–3 on page 6-9. They are discussed in the sections that follow.

Compare Control Register (COMCON)

The operation of full and simple compare units is controlled by the 16-bit compare control register (COMCON). The bit definition of COMCON is summarized in Figure 6–14. COMCON can be read from, written to, and mapped to data memory.

Figure 6–14. Compare Control Register (COMCON) — Address 7411h

15	14	13	12	11	10	9	8
CENABLE	CLD1	CLD0	SVENABLE	ACTRLD1	ACTRLD0	FCOMPOE	SCOMPOE
RW-0	RW-0	RW-0	RW-0	RW-0	RW-0	RW-0	RW-0
7	6	5	4	3	2	1	0
SELTMR	SCLD1	SCLD0	SACTRLD1	SACTRLD0	SELCMP3	SELCMP2	SELCMP1
RW-0	RW-0	RW-0	RW-0	RW-0	RW-0	RW-0	RW-0

Note: R = read access, W = write access, -0 = value after reset

Bit 15 **CENABLE.** Full compare enable

- 0 = Disable full compare operation. All shadowed registers (CMPRx, SCMPRx, ACTR, and SACTR) become transparent.
- 1 = Enable compare operation.

Bits14–13 **CLD1, CLD0.** Full compare register CMPRx reload condition

- 00 = When T1CNT = 0 (that is, on underflow)
- 01 = When T1CNT = 0 or T1CNT = T1PR (that is, on underflow or period match)
- 10 = Immediately
- 11 = Reserved. Result is unpredictable.

Bit 12 **SVENABLE.** Space vector PWM mode enable. In space vector PWM mode, all six full compare outputs are PWM outputs. SVENABLE = 1 overrides COMCON bits 0, 1, and 2.

- 0 = Disable space vector PWM mode.
- 1 = Enable space vector PWM mode.

- Bits 11–10** **ACTRLD1, ACTRLD0.** Full compare action register ACTR reload condition
- 00 = When T1CNT = 0 (that is, on underflow)
 - 01 = When T1CNT = 0 or T1CNT = T1PR (that is, on underflow or period match)
 - 10 = Immediately
 - 11 = Reserved. Result is unpredictable.
- Bit 9** **FCOMPOE.** Full compare output enable. Active PDPINT clears this bit to 0.
- 0 = Full compare output pins are in the high-impedance state; they are disabled.
 - 1 = Full compare output pins are not in the high-impedance state; they are enabled.
- Bit 8** **SCOMPOE.** Simple compare output enable. Active PDPINT clears this bit to 0
- 0 = Simple compare output pins are in the high-impedance state; they are disabled.
 - 1 = Simple compare output pins are not in the high-impedance state; they are enabled.
- Bit 7** **SELTMR.** Simple compare time base select
- 0 = GP timer 1
 - 1 = GP timer 2
- Bits 6–5** **SCLD1, SCLD0.** Simple compare register SCMPRx reload condition
- 00 = When TyCNT = 0 (y = 1 or 2 according to SELTMR)
 - 01 = When TyCNT = 0 or TyCNT = TyPR
 - 10 = Immediately
 - 11 = Reserved
- Bits 4–3** **SACTRLD1, SACTRLD0.** Simple compare action register SACTR reload condition
- 00 = When TyCNT = 0 (y = 1 or 2 according to SELTMR)
 - 01 = When TyCNT = 0 or TyCNT = TyPR
 - 10 = Immediately
 - 11 = Reserved

-
- Bit 2** **SELCMP3.** Mode select for PWM6/CMP6 and PWM5/CMP5 (for full compare unit 3)
- 0 = Compare mode
 - 1 = PWM mode
- Bit 1** **SELCMP2.** Mode select for PWM4/CMP4 and PWM3/CMP3 (for full compare unit 2)
- 0 = Compare mode
 - 1 = PWM mode
- Bit 0** **SELCMP1.** Mode select for PWM2/CMP2 and PWM1/CMP1 (for full compare unit 1)
- 0 = Compare mode
 - 1 = PWM mode

Note:

Two consecutive writes to COMCON are required to ensure the proper operation of full compare units in the PWM mode:

- 1) Enable PWM mode without enabling compare operation.
 - 2) Enable compare operation by setting COMCON[15] to 1 without changing any other bits.
-

Example 6–6 on page 6-54 provides an example of COMCON configuration for full compare units in PWM mode.

Example 6–6. Example of COMCON Configuration for Full Compare Units in PWM Mode

```

;*****
; Configure COMCON register
;*****
    SPLK    #0100101101010111B, COMCON ; COMCON needs to be written twice for
    SPLK    #1100101101010111B, COMCON ; proper operation.
           ||||||||||||||||||
           FEDCBA9876543210
; bit 15   : 1   : Enable PWM
; bit 14-13 :10  : Load compare immediate
; bit 12    : 0   : Disable SV
; bit 11-10 :10  : Load ACTR immediate
; bit 9     : 1   : PWM specified by ACTR
; bit 8     : 1   : SPWM specified by SACTR
; bit 7     : 0   : Simple compare are associated with T2
; bit 6-5   :10  : Load SCMPR immediate
; bit 4-3   :10  : Load SACTR immediate
; bit 2     : 1   : CMP6/5 enabled
; bit 1     : 1   : CMP4/3 enabled
; bit 0     : 1   : CMP2/1 enabled

```

Full Compare Action Control Register (ACTR)

Bits in the full compare action control register (ACTR) control the action that takes place on each of the six compare output pins (PWMx/CMPx, x = 1–6) on a compare event. This occurs in both compare and PWM operation modes if the compare operation is enabled by COMCON[15]. ACTR is double buffered. The condition in which the ACTR is reloaded is specified by the bits in COMCON. ACTR also contains the SVRDIR, D2, D1, and D0 bits needed for space-vector PWM operation. The bit configuration of ACTR is shown in Figure 6–15.

Figure 6–15. Full Compare Action Control Register (ACTR) — Address 7413h

15	14	13	12	11	10	9	8
SVRDIR	D2	D1	D0	CMP6ACT1	CMP6ACT0	CMP5ACT1	CMP5ACT0
RW–0	RW–0	RW–0	RW–0	RW–0	RW–0	RW–0	RW–0
7	6	5	4	3	2	1	0
CMP4ACT1	CMP4ACT0	CMP3ACT1	CMP3ACT0	CMP2ACT1	CMP2ACT0	CMP1ACT1	CMP1ACT0
RW–0	RW–0	RW–0	RW–0	RW–0	RW–0	RW–0	RW–0

Note: R = read access, W = write access, –0 = value after reset

Bit 15 **SVRDIR.** Space-vector PWM rotation direction. Used only in space-vector PWM output generation

- 0 = Positive (CCW)
- 1 = Negative (CW)

Bits 14–12 **D2–D0.** Basic space-vector bits. Used only in space-vector PWM output generation

Bits 11–10 **CMP6ACT1, CMP6ACT0.** Action on full compare output pin 6, PWM6/CMP6

Bits 11–10	Compare mode	PWM mode
01	Reset	Active low
10	Set	Active high
11	Toggle	Forced high
00	Hold	Forced low

Bits 9–8 **CMP5ACT1, CMP5ACT0.** Action on full compare output pin 5, PWM5/CMP5

Bits 9–8	Compare mode	PWM mode
00	Hold	Forced low
01	Reset	Active low
10	Set	Active high
11	Toggle	Forced high

Bits 7–6 **CMP4ACT1, CMP4ACT0.** Action on full compare output pin 4, PWM4/CMP4

Bits 7–6	Compare mode	PWM mode
00	Hold	Forced low
01	Reset	Active low
10	Set	Active high
11	Toggle	Forced high

Bits 5–4 **CMP3ACT1, CMP3ACT0.** Action on full compare output pin 3, PWM3/CMP3

Bits 5–4	Compare mode	PWM mode
00	Hold	Forced low
01	Reset	Active low
10	Set	Active high
11	Toggle	Forced high

Bits 3–2 **CMP2ACT1, CMP2ACT0.** Action on full compare output pin 2, PWM2/CMP2

Bits 3–2	Compare mode	PWM mode
00	Hold	Forced low
01	Reset	Active low
10	Set	Active high
11	Toggle	Forced high

Bits 1–0 **CMP1ACT1, CMP1ACT0.** Action on full compare output pin 1, PWM1/CMP1

Bits 1–0	Compare mode	PWM mode
00	Hold	Forced low
01	Reset	Active low
10	Set	Active high
11	Toggle	Forced high

Simple Compare Action Control Register (SACTR)

The action of simple compare output pins on a compare event is defined by the 16-bit simple compare action control register (SACTR). The bit configuration of SACTR is shown in Figure 6–16. SACTR is double buffered. The condition in which the register is reloaded is defined by bits in COMCON.

Figure 6–16. Simple Compare Action Control Register (SACTR) — Address 7414h

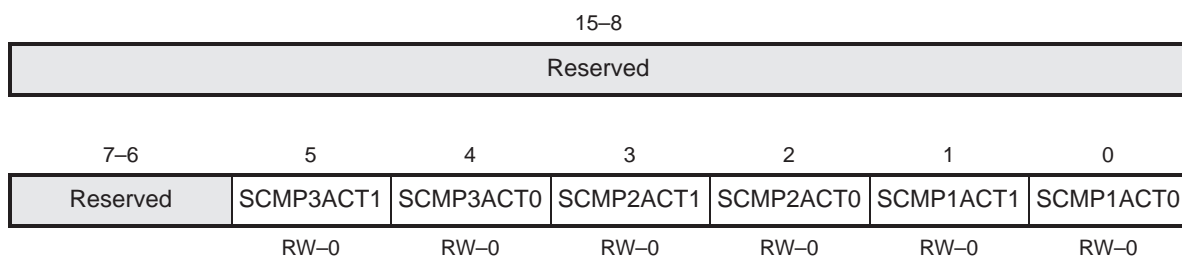

Note: R = read access, W = write access, –0 = value after reset

Bits 15–6 **Reserved.** Reads are 0 and writes have no effect.

Bits 5–4 **SCMP3ACT1, SCMP3ACT0.** Action on simple compare output pin 3, PWM9/CMP9

- 00 = Forced low
- 01 = Active low
- 10 = Active high
- 11 = Forced high

Bits 3–2 **SCMP2ACT1, SCMP2ACT0.** Action on simple compare output pin 2, PWM8/CMP8

- 00 = Forced low
- 01 = Active low
- 10 = Active high
- 11 = Forced high

Bits 1–0	SCMP1ACT1, SCMP1ACT0. Action on simple compare output pin 1, PWM7/ CMP7
00	= Forced low
01	= Active low
10	= Active high
11	= Forced high

6.8.9 Compare Unit Interrupts

There is a maskable interrupt flag for each compare unit in EVIFRA and EVIFRC. An interrupt flag of a compare unit is set two CPU clock cycles after a compare match if the compare operation is enabled.

6.8.10 Compare Unit Reset

When any reset event occurs, all registers associated with the compare units are reset to 0 and all compare output pins are put in the high-impedance state.

6.9 PWM Circuits Associated With Full Compare Units

The PWM circuits associated with full compare units make it possible to generate six PWM output channels with programmable dead-band and output polarity. Figure 6–17 shows a PWM circuit functional block diagram. It includes the following functional units:

- ❑ Asymmetric/symmetric waveform generators
- ❑ Programmable dead-band unit (DBU)
- ❑ Output logic
- ❑ Space-vector (SV) PWM state machine

The asymmetric/symmetric waveform generators are the same as that of a GP timer and simple compare unit. Dead-band units are discussed beginning in section 6.9.2 on page 6-61, and output logic is discussed in section 6.9.6 on page 6-67. The space vector PWM state machine and the space vector PWM technique are described in section 6.11 beginning on page 6-74.

Figure 6–17. PWM Circuits Block Diagram

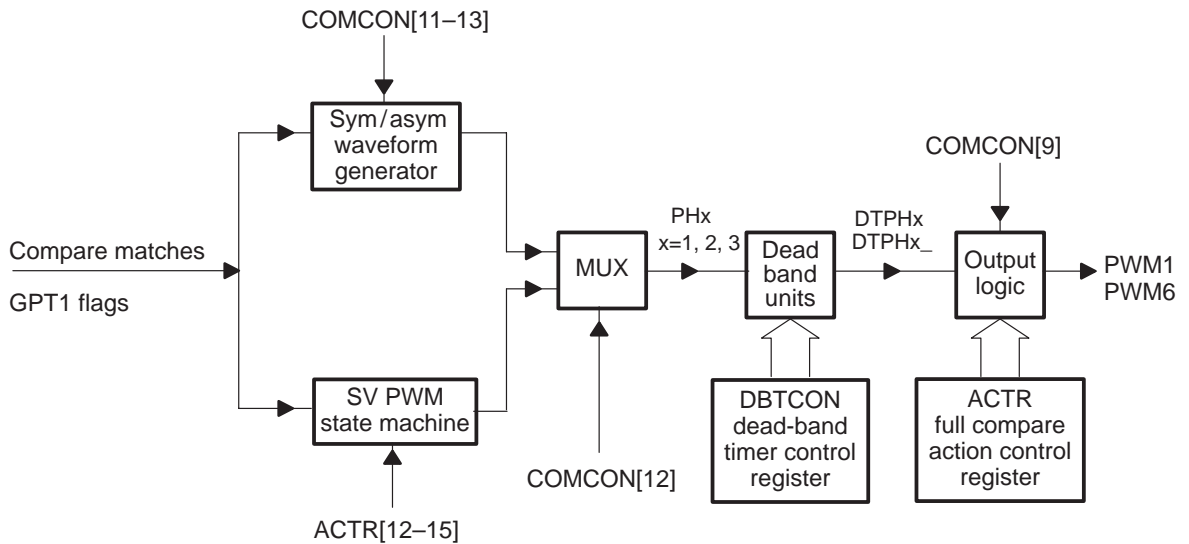

PWM circuits are designed to minimize CPU overhead and user intervention in generating pulse width modulated waveforms used in motor control and motion control applications. PWM generation with full compare units and associated PWM circuits are controlled by the following control registers:

- T1CON
- COMCON
- ACTR
- DBTCON

6.9.1 PWM Generation Capability

The PWM waveform-generation capability of the event manager has the following features:

- Nine independent PWM outputs
- Programmable dead-band for the PWM output pairs associated with full compare units of 0–2048 CPU clock cycles, or 0–102.4 μ s if the CPU clock cycle is 50 ns
- Minimum dead-band increment/decrement of one CPU clock cycle
- Minimum PWM pulse width and pulse width increment/decrement of one CPU clock cycle
- 16-bit maximum PWM resolution
- On-the-fly change of PWM carrier frequency (double-buffered period registers)
- On-the-fly change of PWM pulse widths (double-buffered compare registers)
- Power-drive protection interrupt
- Programmable generation of asymmetric, symmetric, and space-vector PWM waveforms
- Minimum CPU overhead because of the autoreloading of compare and period registers

6.9.2 Programmable Dead-Band Unit

The programmable dead-band unit features:

- One 16-bit dead-band control register, DBTCON (R/W)
- One input clock prescaler: x/1, x/2, x/4, x/8
- CPU clock input
- Three 8-bit down counting timers
- Control logic

Dead-Band Timer Control Register (DBTCON)

The operation of the dead-band unit is controlled by the dead-band timer control register (DBTCON). Figure 6–18 below shows the bit description of DBTCON.

Figure 6–18. Dead-Band Timer Control Register (DBTCON) — Address 7415h

15	14	13	12	11	10	9	8
DBT7	DBT6	DBT5	DBT4	DBT3	DBT2	DBT1	DBT0
RW–0	RW–0	RW–0	RW–0	RW–0	RW–0	RW–0	RW–0
7	6	5	4	3	2–0		
EDBT3	EDBT2	EDBT1	DBTPS1	DBTPS0	Reserved		
RW–0	RW–0	RW–0	RW–0	RW–0			

Note: R = read access, W = write access, –0 = value after reset

Bits 15–8 DBT7 (MSB)–DBT0 (LSB). Dead-band timer period. These bits define the period value of the three 8-bit dead-band timers.

Bit 7 EDBT3. Dead-band timer 3 enable (for pins PWM5/CMP5 and PWM6/CMP6 of full compare unit 3)

- 0 = Disable
- 1 = Enable

Bit 6 EDBT2. Dead-band timer 2 enable (for pins PWM3/CMP3 and PWM4/CMP4 of full compare unit 2)

- 0 = Disable
- 1 = Enable

Bit 5 EDBT1. Dead-band timer 1 enable (for pins PWM1/CMP1 and PWM2/CMP2 of full compare unit 1)

- 0 = Disable
- 1 = Enable

Bits 4–3 **DBTPS1, DBTPS0.** Dead-band timer prescaler

00 = $x/1$

01 = $x/2$

10 = $x/4$

11 = $x/8$

where: x = CPU clock frequency

Bits 2–0 **Reserved.** Reads are 0, and writes have no effect.

Shoot-Through Fault[†]

COMCON bits 8 and 9 should be used to disable the compare outputs, not COMCON bit 15. Disabling the compare operation using COMCON bit 15 when deadband is enabled could result in a shoot-through fault.

[†] A shoot-through fault occurs when the upper and lower power devices (power transistors) switch on at the same time, momentarily.

6.9.3 Inputs and Outputs of Dead-Band Unit

The inputs to the dead-band unit are PH1, PH2, and PH3 from the asymmetric/symmetric waveform generators of full compare units 1, 2, and 3, respectively.

The outputs of the dead-band unit are DTPH1, DTPH1_; DTPH2, DTPH2_; and DTPH3, and DTPH3_ corresponding to PH1, PH2, and PH3, respectively.

6.9.4 Dead-Band Generation

For each input signal PH x , two output signals, DTPH x and DTPH x _, are generated. When the dead band is not enabled for the compare unit and its associated outputs, the two signals are exactly the same. When the dead-band unit is enabled for the compare unit, the transition edges of the two signals are separated by a time interval called the dead band. This time interval is determined by the DBTCON bits. For example, If the value in DBTCON[15–8] is m and the value in DBTCON[4–3] corresponds to prescaler x/p , then the dead-band value is $(p*m)$ CPU clock cycles.

Table 6–8 shows the dead band generated by typical bit combinations in DBTCON. The values are based on a 50-ns device. Figure 6–19 shows the block diagram of the dead-band logic for one full compare unit.

Table 6–8. Dead-Band Generation Examples

DBT7–DBT0 (m) (DBTCON[15–8])	DBTSP1–DBTSP0 (p) (DBTCON[4–3])			
	11 (P = 8)	10 (P = 4)	01 (P = 2)	00 (P = 1)
00h	0	0	0	0
01h	0.40	0.20	0.10	0.05
02h	0.80	0.40	0.20	0.10
03h	1.20	0.60	0.30	0.15
04h	1.60	0.80	0.40	0.20
05h	2.00	1.00	0.50	0.25
06h	2.40	1.20	0.60	0.30
07h	2.80	1.40	0.70	0.35
08h	3.20	1.60	0.80	0.40

Note: Table values are given in μs .

Figure 6–19. Dead-Band Unit Block Diagram ($x = 1, 2, \text{ or } 3$)

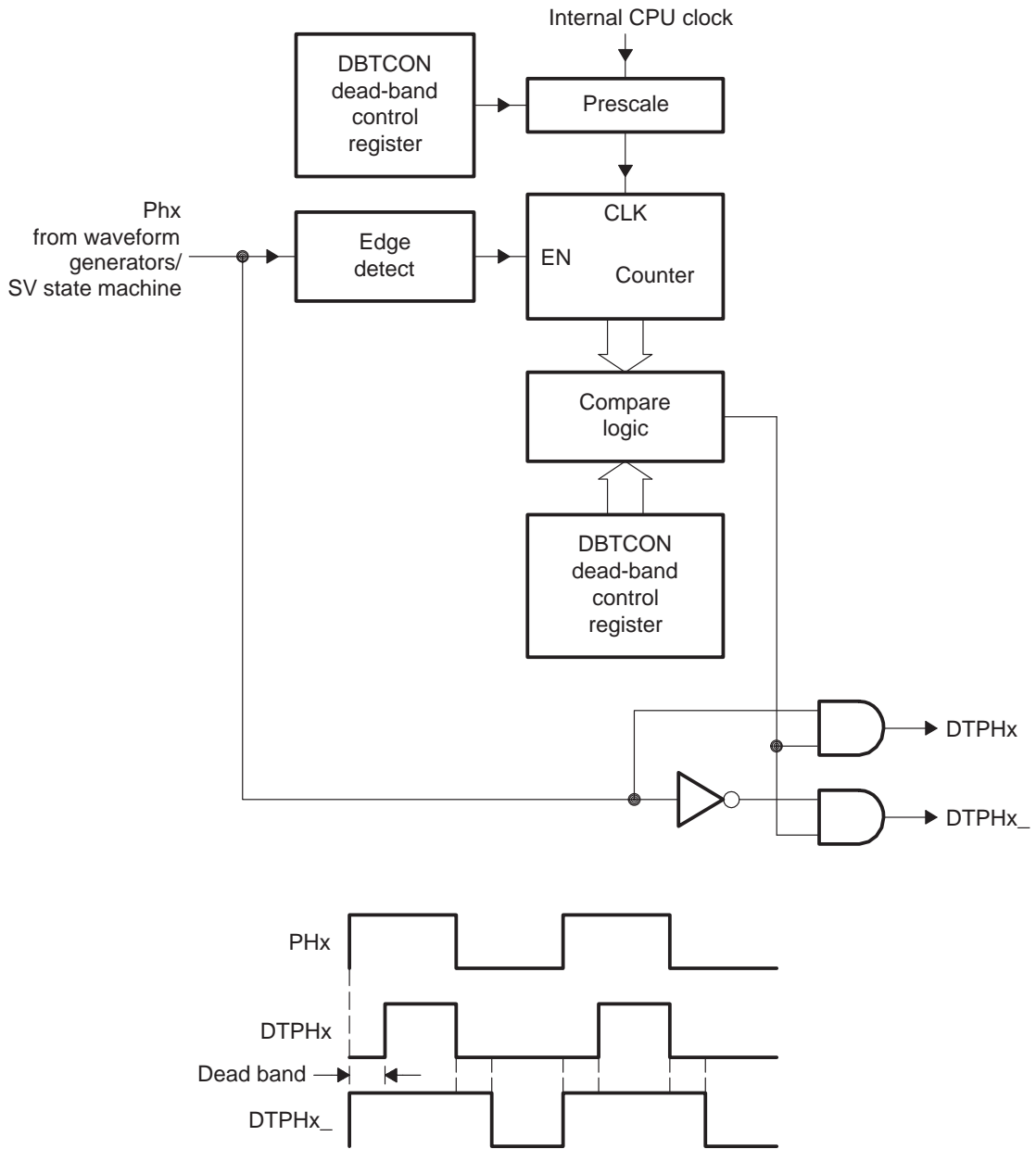

6.9.5 Other Important Features of Dead-Band Units

The dead-band unit is designed to assure that no overlap occurs between the turn-on periods of the upper and lower devices that are controlled by the two compare/PWM outputs associated with each full compare unit. This assures that no overlap will occur under any condition, including when the user has loaded a dead-band value greater than that of the duty cycle, and when the duty cycle is 100% or 0%. As a result, the compare/PWM outputs associated with a full compare unit do not reset to an inactive state at the end of a period when the dead band is enabled for the full compare unit.

The dead-band is disabled when a full compare unit is in the compare mode.

Example 6–7 shows a full compare initialization routine for symmetric PWM waveform generation with the dead-band unit activated.

Example 6–7. Initialization Routine for Dead-Band Generation

```

;*****
; The following section of code initializes symmetric PWM with dead-band
;*****
        LDPK    #232                ; DP => EV registers
;*****
; Configure ACTR
;*****
        SPLK    #000011001100110b, ACTR ; GP Timer control
;
        |
;
        FEDCBA9876543210
;
* bit 15      0      SV rotation direction (for here not applicable)
* bits 12-14  000    Space-vector bits (for here not applicable)
* bits 10-11  01     PWM6 active low
* bits 8-9    10     PWM5 active high
* bits 6-7    01     PWM4 active low
* bits 4-5    10     PWM3 active high
* bits 2-3    01     PWM2 active low
* bits 0-1    10     PWM1 active high
;*****
; Configure DBTCON
;*****
        SPLK    #000010111100000b, DBTCON ; Timer control
;
        |
;
        FEDCBA9876543210
* bits 8-15   101    : 5 cycles of dead-band
* bit 7       1      : Enable DB for PWM 5/6
* bit 6       1      : Enable DB for PWM 3/4
* bit 5       1      : Enable DB for PWM 1/2
* bits 3-4    00     : Timer prescaler for DB unit /1
* bits 0-2    000    : Reserved
;*****
; Initialize compare registers
;*****
        SPLK    #0008h, CMPR1
        SPLK    #000Ch, CMPR2
        SPLK    #0011h, CMPR3
;*****
; Initialize T1PER register
;*****
        SPLK    #0014h, T1PER

```

6.9.6 Output Logic

The output logic circuit for full and simple compare units determines the polarity and/or action that must be taken on a compare match for outputs PWMx/CMPx, for x = 1–9. Outputs associated with each full compare unit can be specified active low, active high, forced low, or forced high when the full compare unit is in PWM mode (the same as outputs associated with a simple compare unit and GP timers). They can be specified to hold, set, reset, or toggle when the compare unit is in compare mode. The polarity and/or action of full and simple compare/PWM outputs can be programmed by proper configuration of bits in ACTR and SACTR. The six full compare/PWM and three simple compare/PWM output pins can be put into the high-impedance state by any of the following:

- Resetting the COMCON[9] and COMCON[8] bits (software).
- Pulling PDPINT low when PDPINT is unmasked (hardware).
- Any reset event

Active PDPINT (when unmasked) and system reset override bits in COMCON, ACTR, and SACTR.

Figure 6–20 shows a block diagram of the output logic circuit (OLC) associated with full compare units. The inputs to the output logic of the full and simple compare units include:

- DTPH1, DTPH1_, DTPH2, DTPH2_, DTPH3, and DTPH3_ from the dead-band unit and full compare match signals
- Outputs from the simple compare unit's asymmetric/symmetric waveform generator
- ACTR and SACTR bits
- PDPINT and RESET

The outputs of the output logic circuit for full and simple compare units are given by: PWMx/CMPx, where x = 1–9.

Figure 6–20. Output Logic Block Diagram ($x = 1, 2, \text{ or } 3; y = 1, 2, 3, 4, 5, \text{ or } 6$)

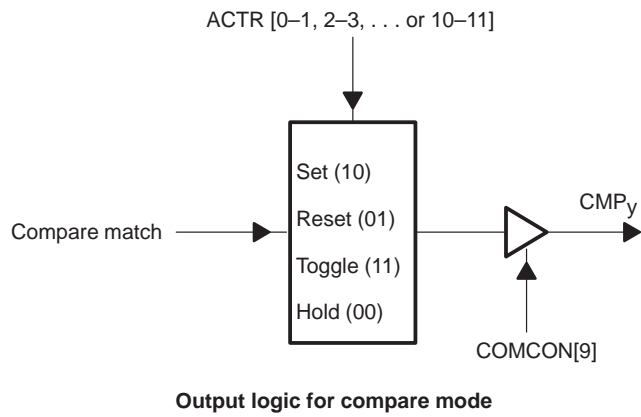
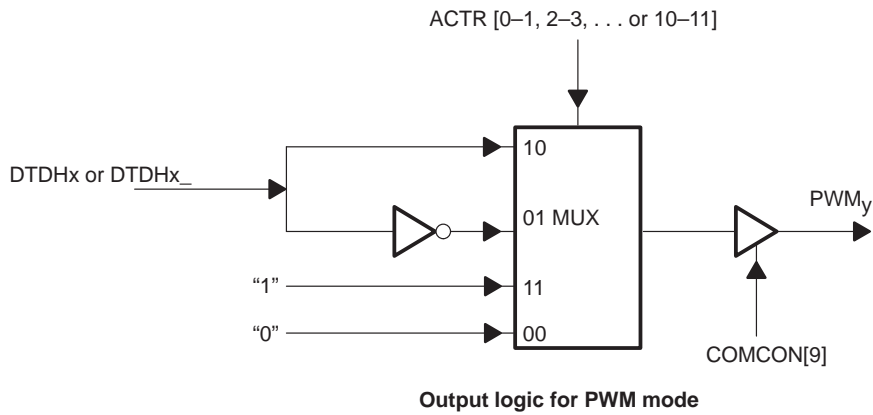

6.10 PWM Waveform Generation With Compare Units and PWM Circuits

This section describes what a PWM signal is, its use in control systems, how it is generated, the two types of PWM waveform generation, and space-vector PWM waveform generation.

6.10.1 PWM Signals

A pulse-width-modulated (PWM) signal is a sequence of pulses with changing pulse widths. The pulses are spread over a number of fixed-length periods. There is one pulse in each period. The fixed period is called the PWM (carrier) period. Its inverse is called the PWM (carrier) frequency. The widths of the PWM pulses are determined or modulated from pulse to pulse according to another sequence of desired values, the modulating signal.

In a motor control system, PWM signals are used to control the on and off time of switching power devices that deliver the desired energy to the motor windings (see Figure 6–23 on page 6-74). The shape and frequency of the phase currents and voltages and the amount of energy delivered to the motor windings control the required speed and torque of the motor. The command voltage or current to be applied to the motor is the modulating signal. The frequency of the modulating signal is typically much lower than the PWM carrier frequency.

6.10.2 PWM Signal Generation

To generate a PWM signal, an appropriate timer is needed to repeat a counting period that is the same as the PWM period. A compare register holds the modulating values. The value of the compare register is constantly compared with the value of the timer counter. When the values match, a transition (from low to high or high to low) occurs on the associated output. When a second match is made between the values or when the end of a timer period is reached, another transition (from high to low or low to high) occurs on the associated output. In this way, an output pulse is generated whose on or off duration is proportional to the value in the compare register. This process is repeated for each timer period with different modulating values in the compare register. As a result, a PWM signal is generated at the associated output.

6.10.3 Dead Band

In many motion/motor and power electronics applications, two power devices (an upper and lower) are placed in series on one power converter leg. To avoid a shoot-through fault, the turn-on periods of the two devices must not overlap. Thus, a pair of non-overlapping PWM outputs is often required to turn the two devices on and off properly. A dead time (dead band) is often inserted between the turning off of one transistor and the turning on of the other transistor. This delay allows complete turning off of one transistor before the turning on of the other transistor. The required time delay is specified by the turning on and turning off characteristics of the power transistors and the load characteristics in a specific application.

6.10.4 Generation of PWM Outputs With Event Manager

Each of the three full compare units together with GP timer 1, the dead-band unit, and the output logic in the EV module can be used to generate a pair of PWM outputs with programmable dead-band and output polarity. There are six such PWM outputs associated with the three full compare units in the EV module. These six outputs can be used to control 3-phase AC induction or brushless DC motors. The flexibility of output behavior control by the full compare action control register (ACTR) also makes it easy to control switched and synchronous reluctance motors in a wide range of applications.

The PWM circuits can control other types of motors such as DC brush and stepper motors in single or multi-axis control applications. The three simple compare units together with GP timer 1 or 2 can generate another three PWM outputs in case the dead band is not necessary or is generated by circuits off the chip. Each GP timer compare unit, if desired, can generate a PWM output based on its own timer.

6.10.5 Asymmetric and Symmetric PWM Generation

Both asymmetric and symmetric PWM waveforms can be generated by every compare unit in the EV module. In addition, the three full compare units together can generate 3-phase symmetric space-vector PWM outputs. PWM generation with GP timer compare units is described in section 6.3.9 on page 6-15. PWM generation with simple compare units is similar to PWM generation with GP timer compare units, except that different control registers are used and either GP timer 1 or 2 can be chosen as the time base. Generation of PWM outputs with full compare units is discussed in section 6.11.6 on page 6-78.

6.10.6 Register Setup for PWM Generation

All three kinds of PWM waveform generation with full compare units and associated circuits require configuration of the same EV registers. The setup process for PWM generation includes the following steps:

- 1) Set up and load ACTR.
- 2) Set up and load DBTCON, if dead band is to be used.
- 3) Initialize CMPRx.
- 4) Set up and load COMCON without enabling compare operation.
- 5) Set up and load COMCON to enable compare operation.
- 6) Set up and load T1CON to start the operation.
- 7) Rewrite CMPRx with newly determined values.

Note:

Before T1CON is written to start the operation, COMCON must be written to twice to ensure that all full compare outputs come up in the correct (inactive) states.

6.10.7 Asymmetric PWM Waveform Generation

An edge-triggered or asymmetric PWM signal is characterized by modulated pulses that are not centered with respect to the PWM period, as shown in Figure 6–21. The width of each pulse can be changed only from one side of the pulse.

Figure 6–21. Asymmetric PWM Waveform Generation With Full Compare Unit and PWM Circuits ($x = 1, 3, \text{ or } 5$)

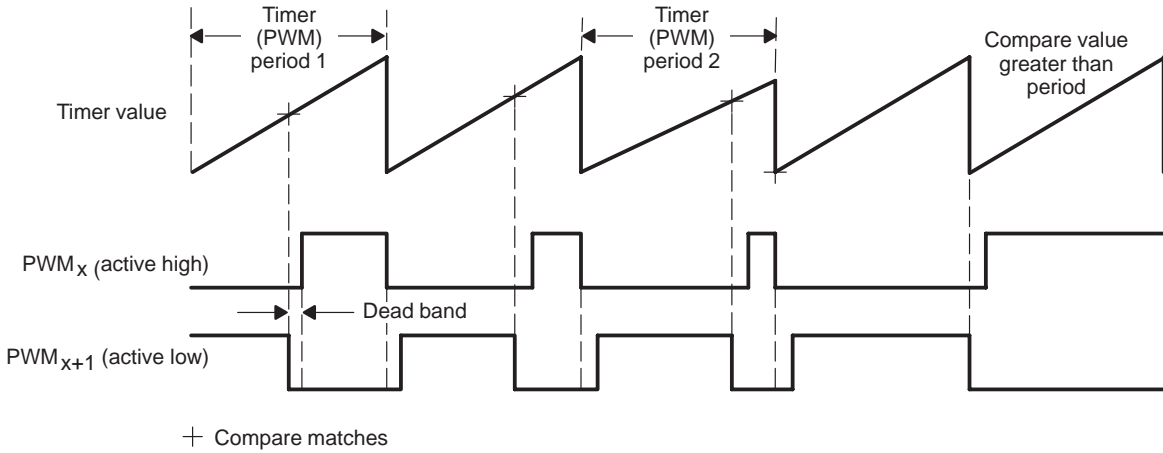

To generate an asymmetric PWM signal with a full compare unit, GP timer 1 must be put in the continuous up counting mode. Its period register must be loaded with a value corresponding to the desired PWM carrier period. Then, the COMCON must be configured to enable the compare operation, set the selected output pins to be PWM outputs, and enable the outputs. If dead-band is enabled, the desired value for the dead-band must be written to the eight most significant bits (MSBs) of DBTCON as the PWM period for the 8-bit dead-band timers.

By proper configuration of ACTR with software, a normal PWM signal can be generated on one output associated with a full compare unit while the other is held low (off) or high (on) at the beginning, middle, or end of a PWM period. Such software-controlled flexibility of PWM outputs is particularly useful in switched reluctance motor-control applications.

After GP timer 1 is started, the compare registers are rewritten every PWM period with newly determined compare values to adjust the width (the duty cycle) of PWM outputs that control the switch-on and -off duration of the power devices. Since the compare registers are shadowed, new values can be written to them at any time during a period. For the same reason, new values can be written to the action and period registers at any time during a period to change the PWM period or to force changes in the PWM output definition.

6.10.8 Symmetric PWM Waveform Generation

A centered or symmetric PWM signal is characterized by modulated pulses that are centered with respect to each PWM period. The advantage of a symmetric over an asymmetric PWM signal is that it has two inactive zones of the same duration — at the beginning and at the end of each PWM period. This symmetry has been shown to cause less harmonics than asymmetric PWM signals in the phase currents of an AC motor. Figure 6–22 shows two examples of symmetric PWM waveforms.

Figure 6–22. Symmetric PWM Waveform Generation With Full Compare Units and PWM Circuits ($x = 1, 3, \text{ or } 5$)

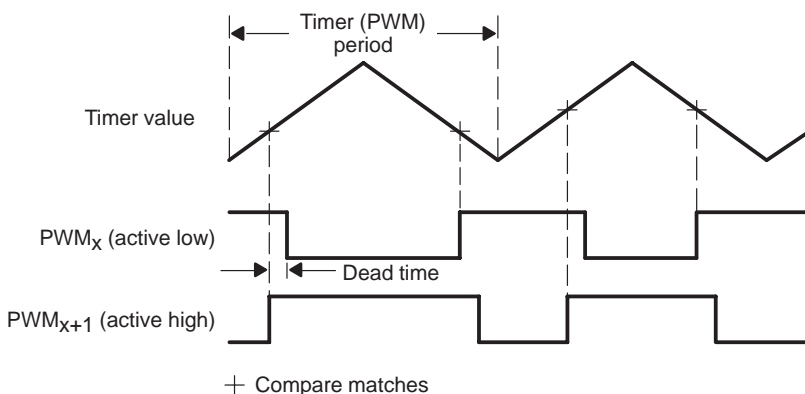

The generation of a symmetric PWM waveform using a full compare unit is similar to the generation of an asymmetric PWM waveform. The difference is that GP timer 1 must be put in the continuous up/down counting mode.

There are usually two compare matches in a PWM period in symmetric PWM waveform generation: one during upward counting before the period match and another during downward counting after the period match. A new compare value can become effective after the period match (reload on period), making it possible to advance or delay the second edge of a PWM pulse. One application of this feature is PWM waveform modification that compensates for current errors caused by the dead band in AC motor control.

Again, since the compare registers are shadowed, a new value can be written to them at any time during a period. For the same reason, new values can be written to the action and period registers at any time during a period to change the PWM period, or to force changes in PWM output definition.

6.11 Space-Vector PWM

Space-vector PWM refers to a special switching scheme of the six power transistors of a 3-phase power converter. It generates minimum harmonic distortion to the currents in the windings of a 3-phase AC motor. It also provides more efficient use of supply voltage than the sinusoidal modulation method.

6.11.1 3-Phase Power Inverter

The structure of a typical 3-phase power inverter is shown in Figure 6–23, where V_a , V_b , and V_c are the voltages applied to the motor windings. The six power transistors are controlled by $DTPH_x$ and $DTPH_{x-}$ ($x = a, b, \text{ and } c$). When an upper transistor is switched on ($DTPH_x = 1$), the lower transistor is switched off ($DTPH_{x-} = 0$). Thus, the on and off states of the upper transistors ($Q_1, Q_3, \text{ and } Q_5$) or, equivalently, the state of $DTPH_x$ ($x = a, b, \text{ and } c$) are sufficient to evaluate the applied motor voltage U_{out} .

Figure 6–23. 3-Phase Power Inverter Schematic Diagram

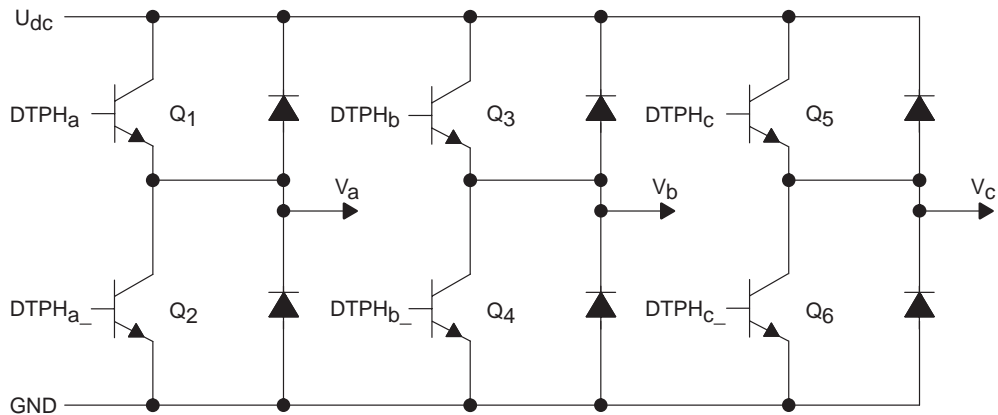

6.11.2 Switching Patterns of a Power Inverter and Basic Space Vectors

When an upper transistor of a leg is on, the voltage V_x ($x = a, b, \text{ or } c$) applied by the leg to the corresponding motor winding is equal to the voltage supply U_{dc} . When it is off, the voltage applied is 0. The on and off switching of the upper transistors ($DTPH_x$, $x = a, b, \text{ or } c$) has eight possible combinations. These combinations and the derived motor line-to-line and phase voltage, in terms of DC supply voltage U_{dc} , are shown in Table 6–9. Note that $a, b, \text{ and } c$ represent the values of $DTPH_a, DTPH_b, \text{ and } DTPH_c$, respectively.

Table 6–9. Switching Patterns of a 3-Phase Power Inverter

a	b	c	$V_{a0}(U_{dc})$	$V_{b0}(U_{dc})$	$V_{c0}(U_{dc})$	$V_{ab}(U_{dc})$	$V_{bc}(U_{dc})$	$V_{ca}(U_{dc})$
0	0	0	0	0	0	0	0	0
0	0	1	$-1/3$	$-1/3$	$2/3$	0	-1	1
0	1	0	$-1/3$	$2/3$	$-1/3$	-1	1	0
0	1	1	$-2/3$	$1/3$	$1/3$	-1	0	1
1	0	0	$2/3$	$-1/3$	$-1/3$	1	0	-1
1	0	1	$1/3$	$-2/3$	$1/3$	1	-1	0
1	1	0	$1/3$	$1/3$	$-2/3$	0	1	-1
1	1	1	0	0	0	0	0	0

Note: 0 = off and 1 = on

You can map the phase voltages corresponding to the eight combinations onto the d–q plane by performing a d–q transformation. This is equivalent to an orthogonal projection of the three vectors (a, b, and c) onto the two dimensional plane perpendicular to the vector (1, 1, 1), the d–q plane. This results in six nonzero vectors and two zero vectors. The nonzero vectors form the axes of a hexagon. The angle between two adjacent vectors is 60 degrees, with the two zero vectors at the origin. The eight vectors are called *basic space vectors* and are denoted by $U_0, U_{60}, U_{120}, U_{180}, U_{240}, U_{300}, O_{000}$, and O_{111} . The same transformation can be applied to the demanded voltage vector U_{out} of a motor. Figure 6–24 shows the projected vectors and the projected desired motor-voltage vector U_{out} . The d axis and q axis of the d–q plane correspond to the horizontal and vertical geometrical axes of the stator of an AC machine.

The space-vector PWM method approximates the motor voltage vector U_{out} using a combination of these eight switching patterns of the six power transistors.

Figure 6–24. Basic Space Vectors and Switching Patterns

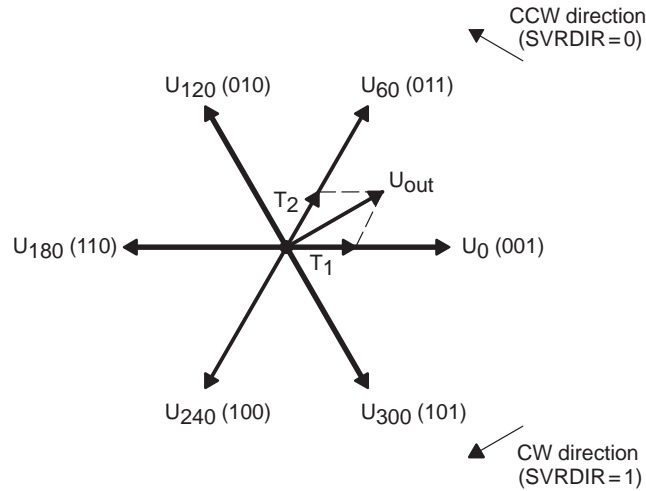

The binary representations of two adjacent basic vectors are different in only one bit. That is, only one of the upper transistors switches when the switching pattern changes from U_x to U_{x+60} or from U_{x+60} to U_x . Also, the zero vectors O_{000} and O_{111} apply no voltage to the motor.

6.11.3 Approximation of Motor Voltage with Basic Space Vectors

The projected motor-voltage vector U_{out} falls in one of the six sectors at any given time. Thus, for any PWM period, it can be approximated by the vector sum of two vector components lying on the two adjacent basic vectors:

$$U_{out} = \frac{T_1}{T_p} U_x + \frac{T_2}{T_p} U_{x+60} + \frac{T_0}{T_p} (O_{000} \text{ or } O_{111})$$

where T_0 is given by $T_p - T_1 - T_2$ and T_p is the PWM carrier period.

The third term on the right side of this equation does not affect the vector sum U_{out} . (The generation of U_{out} is beyond the scope of this context). For more information, refer to specific publications on space vector PWM and motor control theory such as *The Field Orientation Principle in Control of Induction Motors* by Andrzej M. Trzynadlowski.

The above approximation means that the upper transistors must have the on and off pattern corresponding to U_x and U_{x+60} for the time duration of T_1 and T_2 , respectively, in order to apply voltage U_{out} to the motor. Including zero basic vectors helps to balance the turn-on and -off periods of the transistors and thus their power dissipation.

6.11.4 Space-Vector PWM Waveform Generation With EV

The EV module has built-in hardware to greatly simplify the generation of symmetric space-vector PWM waveforms. A description of the software/hardware requirements for generating space vector PWM waveforms follows.

Software

To generate space-vector PWM outputs, the user software must:

- Configure ACTR to define the polarity for full compare output pins
- Configure COMCON to enable the compare operation and space vector PWM mode and set the reload condition for ACTR and CMPRx to be underflow
- Put GP timer 1 in continuous up/down counting mode to start the operation

Note:

Enabling space-vector PWM mode automatically sets all full compare output pins as PWM outputs.

The user software then must

- Determine the voltage U_{out} to be applied to the motor phases in the two-dimensional d–q plane
- Decompose U_{out}
- Do the following for each PWM period:
 - Determine the two adjacent vectors, U_x and U_{x+60}
 - Determine the parameters T_1 , T_2 , and T_0
 - Write the switching pattern corresponding to U_x in ACTR[14–12] and 0 in ACTR[15], or the switching pattern of U_{x+60} in ACTR[14–12] and 1 in ACTR[15]
 - Put $(1/2 T_1)$ in CMPR1 and $(1/2 T_1 + 1/2 T_2)$ in CMPR2 if ACTR[15] is 0, or put $(1/2 T_2)$ in CMPR1 and $(1/2 T_1 + 1/2 T_2)$ in CMPR2 if ACTR[15] is 1.

Space-Vector PWM Hardware

The space-vector PWM hardware in the EV module does the following to complete a space-vector PWM period:

- ❑ At the beginning of each period, sets the PWM outputs to the (new) pattern U_y defined by ACTR[14–12]
- ❑ On the first compare match during up counting between CMPR1 and GP timer 1, switches the PWM outputs to the pattern of U_{y+60} if ACTR[15] is 0, or to the pattern of U_y if ACTR[15] is 1. $U_{0-60} = U_{300}$, $U_{360+60} = U_{60}$
- ❑ On the second compare match during up counting between CMPR2 and GP timer 1 at $(1/2 T1 + 1/2 T2)$, switches the PWM outputs to the pattern (000) or (111), whichever differs from the second pattern by one bit
- ❑ On the first compare match during down counting between CMPR2 and GP timer 1, switches the PWM outputs back to the second output pattern
- ❑ On the second compare match during down counting between CMPR1 and GP timer 1, switches the PWM outputs back to the first output pattern

6.11.5 Space-Vector PWM Waveforms

The space-vector PWM waveforms generated are symmetric with respect to the middle of each PWM period. Figure 6–25 on page 6-79 shows two examples of symmetric space-vector PWM waveforms.

6.11.6 Unused Full Compare Register

Only two full compare registers are used in space-vector PWM output generation. The third full compare register, however, is still constantly compared with GP timer 1. When a compare match occurs, the corresponding compare interrupt flag is set. Therefore, the compare register that is not used in the space-vector PWM output generation can still be used to time events occurring in a specific application. Also, because of the extra delay introduced by the state machine, the full compare output transitions are delayed by two CPU clock cycles in space-vector PWM mode.

6.11.7 Space-Vector PWM Boundary Conditions

All three full compare outputs become inactive when both full compare registers (CMPR1 and CMPR2) are loaded with a zero value in the space-vector PWM mode. In general, it is the user's responsibility to assure that $(CMPR1) \leq (CMPR2) \leq (T1PR)$ in the space vector PWM mode; otherwise, unpredicted behavior may result.

Figure 6–25. Symmetric Space-Vector PWM Waveforms

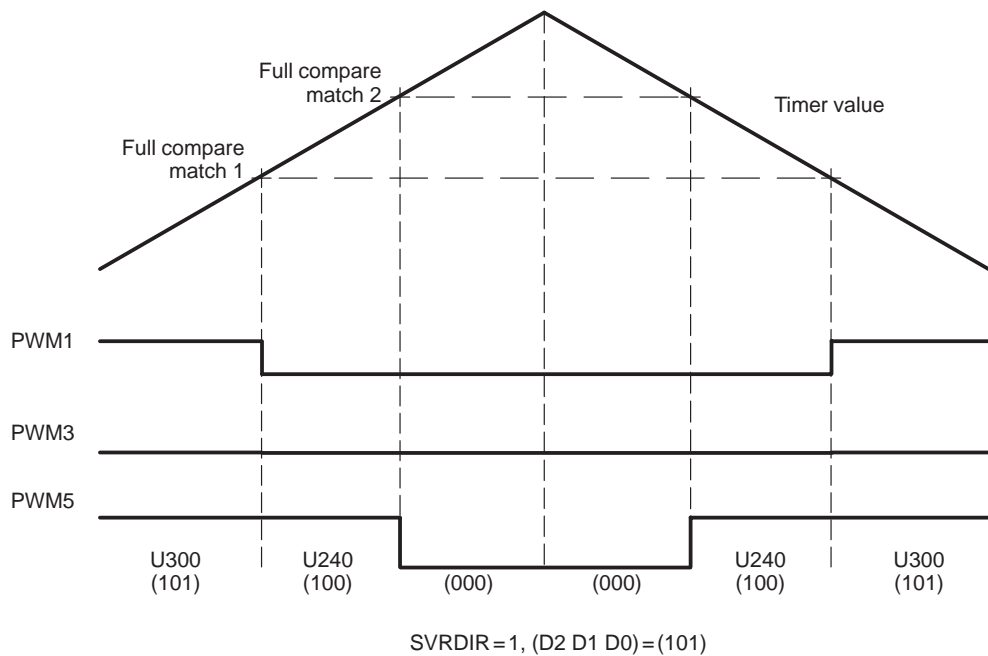
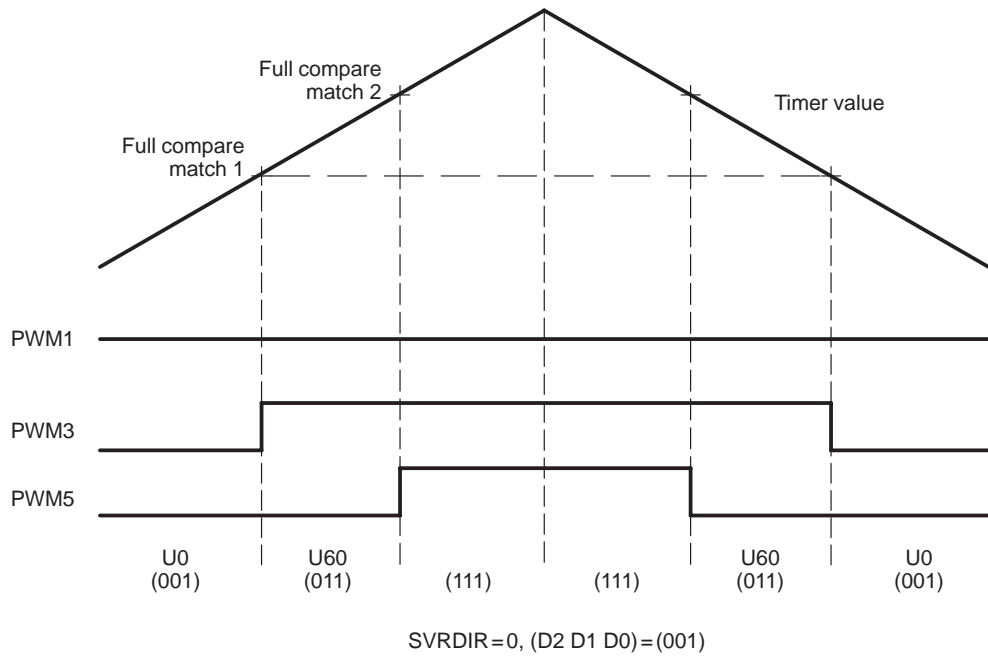

Note: PWM outputs are active high.

6.12 Capture Units

Capture units enable logging of transitions on capture input pins. There are four capture units: 1, 2, 3, and 4. Each one is associated with a capture input pin. Each capture unit can choose GP timer 2 or 3 as its time base. The value of GP timer 2 or 3 is captured and stored in the corresponding 2-level-deep FIFO stack when a specified transition is detected on a capture input pin, CAPx. Figure 6–26 shows a block diagram of the capture unit.

Figure 6–26. Capture Units Block Diagram

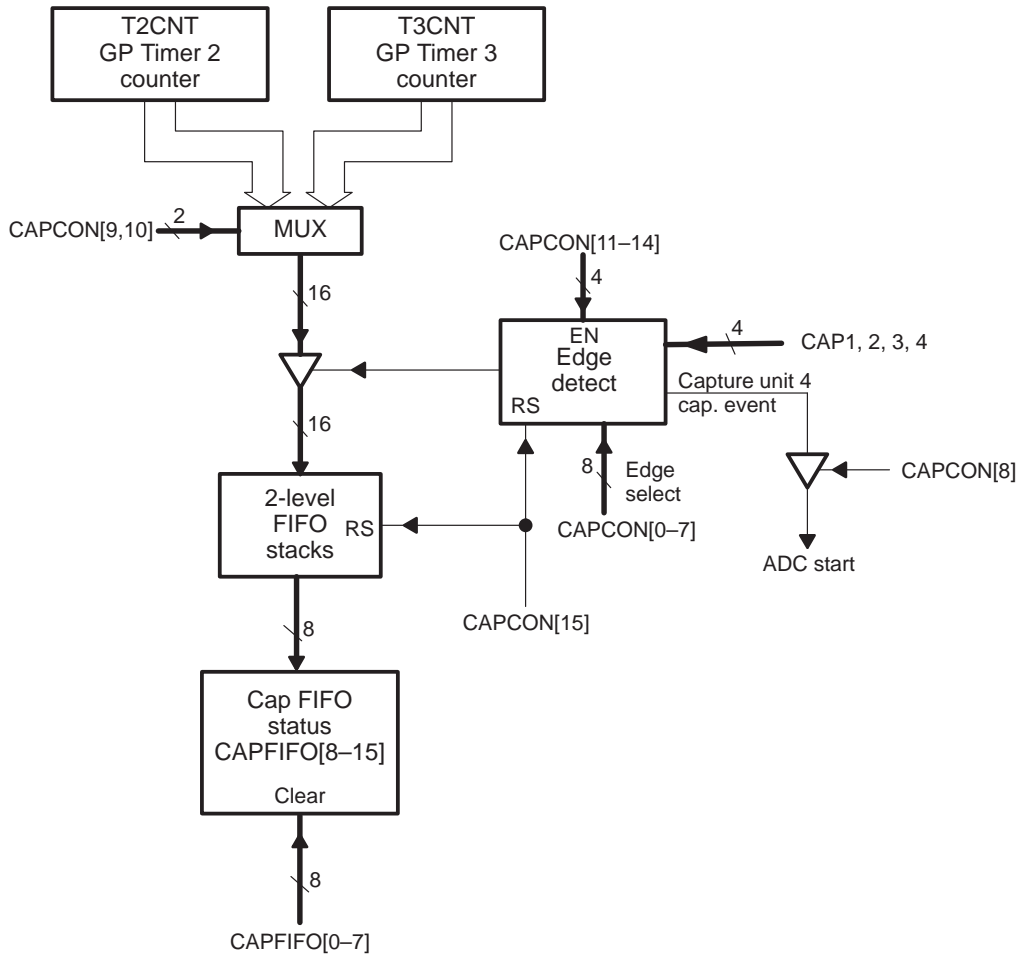

6.12.1 Features

Capture units have the following features:

- One 16-bit capture control register, CAPCON (R/W)
- One 16-bit capture FIFO status register, CAPFIFO (eight MSBs are read only, eight LSBs are write only)
- Ability to select GP timer 2 or 3 as the time base
- Four 16-bit 2-level-deep FIFO stacks, one for each capture unit
- Four Schmitt-triggered capture input pins CAP1, CAP2, CAP3, and CAP4, one input pin per each capture unit. (All inputs are synchronized with the CPU clock. For a transition to be captured, the input must hold at its current level to meet the two rising edges of the CPU clock. The input pins CAP1 and CAP2 can also be used as QEP inputs to a QEP circuit.)
- User-specified transition (rising edge, falling edge, or both edges) detection
- Four maskable flags, one for each capture unit

6.12.2 Operation of Capture Units

The following three paragraphs describe the operation of the capture units, their association with GP timers, compare/PWM operation, transitions on associated pins, and the register setup.

Capture Unit Time Base Selection

Either GP timer 2 or 3 can be selected by capture units 1 and 2 or by capture units 3 and 4. In this way, two GP timers can be used at the same time, one for each pair of capture units.

Capture operation does not affect the operation of any GP timer or the compare/PWM operations associated with any GP timer.

Capture Operation

After a capture unit is enabled, a specified transition on the associated input pin causes:

- the counter value of the selected GP timer to be locked into the corresponding FIFO stack
- the corresponding interrupt flag to be set

Afterwards, the corresponding status bits in CAPFIFO are adjusted to reflect the new status of the FIFO stack each time a new counter value is captured into a FIFO stack. The latency, from the time a transition occurs on a capture input to the time the counter value of the selected GP timer is locked, is 3.5–4.5 CPU clock cycles.

All capture unit registers are cleared when the RESET input goes low.

Capture Unit Setup

For a capture unit to function properly, the following register setup is performed:

- 1) Initialize the CAPFIFO. Clear the appropriate status bits.
- 2) Set the selected GP timer in one of its operating modes.
- 3) Set the associated GP timer compare register or GP timer period register if necessary.
- 4) Set up CAPCON.

6.12.3 Capture Unit Registers

The operation of capture units is controlled by two 16-bit control registers, CAPCON and CAPFIFO. The T2CON and T3CON registers are also needed for capture operation because the time base for capture circuits is provided by GP timer 2 or 3. Like all other EV registers, these registers are all data-memory mapped and can be treated by user software as data-memory locations. Table 6–4 on page 6-9 shows the addresses of these registers.

Capture Control Register (CAPCON)

In addition to being one of the two registers controlling the operation of capture units, CAPCON is also used to control the operation of QEP circuits.

Figure 6–27. Capture Control Register (CAPCON) — Address 7420h

15	14–13	12	11	10	9	8
CAPRES	CAPQEPN	CAP3EN	CAP4EN	CAP34TSEL	CAP12TSEL	CAP4TOADC
RW–0	RW–0	RW–0	RW–0	RW–0	RW–0	RW–0
7–6	5–4	3–2	1–0			
CAP1EDGE	CAP2EDGE	CAP3EDGE	CAP4EDGE			
RW–0	RW–0	RW–0	RW–0			

Note: R = read access, W = write access, –0 = value after reset

Bit 15 **CAPRES.** Capture reset

This is a write-only bit. Any read operation of this bit results in 0. Writing 0 to bit 15 clears all the capture and QEP registers. However, you do not need to write 1 to bit 15 in order to enable the capture function.

- 0 = Clear all capture units registers and the QEP circuit to 0
- 1 = No action

Bits 14–13 **CAPQEPN.** Capture units 1 and 2 and QEP circuit control

- 00 = Disable capture units 1 and 2, and the QEP circuit (The FIFO stacks retain their contents)
- 01 = Enable capture units 1 and 2, disable the QEP circuit
- 10 = Reserved
- 11 = Enable QEP circuit, disable capture units 1 and 2 (Bits 4–7 and 9 are ignored)

Bit 12 **CAP3EN.** Capture unit 3 control

- 0 = Disable capture unit 3 (FIFO stack of capture unit 3 retains its contents)
- 1 = Enable capture unit 3

Bit 11 **CAP4EN.** Capture unit 4 control

- 0 = Disable capture unit 4 (The FIFO stack of capture unit 4 retains its contents)
- 1 = Enable capture unit 4

Bit 10 **CAP34TSEL.** GP timer selection for capture units 3 and 4

- 0 = Select GP timer 2
- 1 = Select GP timer 3

- Bit 9** **CAP12TSEL.** GP timer selection for capture units 1 and 2
- 0 = Select GP timer 2
 - 1 = Select GP timer 3
- Bit 8** **CAP4TOADC.** Capture unit 4 event starts ADC
- 0 = No action
 - 1 = Start ADC when the CAP4INT flag is set
- Bits 7–6** **CAP1EDGE.** Edge detection control for capture unit 1
- 00 = No detection
 - 01 = Detect rising edge
 - 10 = Detect falling edge
 - 11 = Detect both edges
- Bits 5–4** **CAP2EDGE.** Edge detection control for capture unit 2
- 00 = No detection
 - 01 = Detect rising edge
 - 10 = Detect falling edge
 - 11 = Detect both edges
- Bits 3–2** **CAP3EDGE.** Edge detection control for capture unit 3
- 00 = No detection
 - 01 = Detect rising edge
 - 10 = Detect falling edge
 - 11 = Detect both edges
- Bits 1–0** **CAP4EDGE.** Edge detection control for capture unit 4
- 00 = No detection
 - 01 = Detect rising edge
 - 10 = Detect falling edge
 - 11 = Detect both edges

Capture FIFO Status Register (CAPFIFO)

CAPFIFO contains the status bits for each of the four FIFO stacks of capture units. The bit description of CAPFIFO is given in Figure 6–28. The eight LSBs of CAPFIFO have a one-to-one correspondence with the eight MSBs of CAPFIFO. A 1 written to CAPFIFO[x], x = 0, 1, ... or 7, clears bit CAPFIFO[x+8]. CAPFIFO[x], for x = 0, 1, ... 7, are write only and CAPFIFO[y], for y = 8, 9, ... 15, are read only.

Figure 6–28. Capture FIFO Status Register (CAPFIFO) — Address 7422h

15–14		13–12		11–10		9–8	
CAP4FIFO		CAP3FIFO		CAP2FIFO		CAP1FIFO	
R–0		R–0		R–0		R–0	
7	6	5	4	3	2	1	0
CAPFIFO15	CAPFIFO14	CAPFIFO13	CAPFIFO12	CAPFIFO11	CAPFIFO10	CAPFIFO9	CAPFIFO8
W–0	W–0	W–0	W–0	W–0	W–0	W–0	W–0

Note: R = read access, W = write access, –0 = value after reset

Bits 15–14 CAP4FIFO. CAP4FIFO status. Read only

- 00 = Empty
- 01 = Has one entry
- 10 = Has two entries
- 11 = Had two entries and captured another one; first entry has been lost

Bits 13–12 CAP3FIFO. CAP3FIFO status. Read only

- 00 = Empty
- 01 = Has one entry
- 10 = Has two entries
- 11 = Had two entries and captured another one; first entry has been lost

Bits 11–10 CAP2FIFO. CAP2FIFO status. Read only

- 00 = Empty
- 01 = Has one entry
- 10 = Has two entries
- 11 = Had two entries and captured another one; first entry has been lost

Bits 9–8 CAP1FIFO. CAP1FIFO status. Read only

- 00 = Empty
- 01 = Has one entry
- 10 = Has two entries
- 11 = Had two entries and captured another one; first entry has been lost

- Bit 7** **CAPFIFO15.** CAP4FIFO bit 15 clear. Write only
0 = Do nothing
1 = Clear bit 15
- Bit 6** **CAPFIFO14.** CAP4FIFO bit 14 clear. Write only
0 = Do nothing
1 = Clear bit 14
- Bit 5** **CAPFIFO13.** CAP3FIFO bit 13 clear. Write only
0 = Do nothing
1 = Clear bit 13
- Bit 4** **CAPFIFO12.** CAP3FIFO bit 12 clear. Write only
0 = Do nothing
1 = Clear bit 12
- Bit 3** **CAPFIFO11.** CAP2FIFO bit 11 clear. Write only
0 = Do nothing
1 = Clear bit 11
- Bit 2** **CAPFIFO10.** CAP2FIFO bit 10 clear. Write only
0 = Do nothing
1 = Clear bit 10
- Bit 1** **CAPFIFO9.** CAP1FIFO bit 9 clear. Write only
0 = Do nothing
1 = Clear bit 9
- Bit 0** **CAPFIFO8.** CAP1FIFO bit 8 clear. Write only
0 = Do nothing
1 = Clear bit 8

6.12.4 Capture Unit FIFO Stacks (CAPnFIFO, n = 1, 2, 3, 4)

Each capture unit has a dedicated 2-level-deep FIFO stack. The top-level register of any of the FIFO stacks is a read-only register that always contains the older counter value captured by the corresponding capture unit. Therefore, a read access to the FIFO stack of a capture unit always reads out the older counter value captured in the stack. When the older counter value in the top register of the FIFO stack is read, the newer counter value in the bottom register of the stack, if any, is pushed into the top register. Descriptions of the three capture operations follow.

First Capture

The counter value of the selected GP timer is captured by a capture unit when a specified transition occurs on its input pin. It is written into the top register of the stack if the stack is empty. At the same time, the corresponding status bits are set to 01. The status bits are reset to 00 if a read access is made to the FIFO stack before another capture occurs.

Second Capture

If another capture occurs before the previous counter value is read, the new counter value goes into the bottom register. The corresponding status bits are set to 10. When the FIFO stack is read before another capture, the older counter value in the top register is read out, the newer counter value in the bottom register is pushed up into the top register, and the corresponding status bits are set to 01.

Third Capture

If a capture happens when there are already two counter values in the FIFO stack, the oldest counter value in the top register of the stack is pushed out and lost. Next, the counter value in the bottom register of the stack is pushed up into the top register, the newly captured counter value is written into the bottom register, and the status bits are set to 11 to indicate one or more older captured counter values have been lost.

Example 6–8 on page 6-88 shows an initialization routine for capture units.

Example 6–8. Initialization Routine for Capture Units

```

;*****
; Initialize counter registers *
;*****
        LDP #232
        SPLK #00000H,T1CNT; GP Timer 1 counter
        SPLK #00000H,T2CNT; GP Timer 2 counter
        SPLK #00000H,T3CNT; GP Timer 3 counter
;*****
; Initialize period registers *
;*****
        SPLK #00011H,T1PR ; GP Timer 1 period
        SPLK #07fffH,T2PR ; GP Timer 2 period
        SPLK #00011H,T3PR ; GP Timer 3 period
;*****
; Initialize compare registers *
;*****
        SPLK #00004H,T1CMPR; GP Timer 1 Comp Value
        SPLK #00006H,T2CMPR; GP Timer 2 Comp Value
        SPLK #00008H,T3CMPR; GP Timer 3 Comp Value
;*****
; Configure GPTCON *
;*****
        SPLK #000000001010101b,GPTCON
                ; Set GP Timer control
* bits 12-11      00:   No GP Timer 3 event starts ADC
* bits 10-9      00:   No GP Timer 2 event starts ADC
* bits 8-7       00:   No GP Timer 1 event starts ADC
* bit 6          1:    Enable GP Timer Compare outputs
* bits 5-4       01:   GP Timer 3 comp output active low
* bits 3-2       01:   GP Timer 2 comp output active low
* bits 1-0       01:   GP Timer 1 comp output active low
;*****
; Clear all EV interrupts before operation starts *
;*****
        SPLK #0ffffh,EVIFRA ; Clear all Group A interrupt flags
        SPLK #0ffffh,EVIFRB ; Clear all Group B interrupt flags
        SPLK #0ffffh,EVIFRC ; Clear all Group C interrupt flags
;*****
; Configure T2CON and start GP Timer 2 *
;*****
        SPLK #100100001000010b,T2CON
                ; Set GP Timer 2 control
* bit 15        1:    FREE = 1
* bit 14        0:    SOFT = 0
* bits 13-11    010:  continuous-up count mode
* bits 10-8     000:  Prescaler = /1
* bit 7         0:    Use own Timer ENABLE
* bit 6         1:    Timer (counting operation) enabled
* bits 5-4     00:   Select internal CLK

```

Example 6–8. Initialization Routine for Capture Units (Continued)

```

* bits 3-2      00:   Load GP Timer comp register on underflow
* bit 1        1:    GP Timer compare enabled
* bit 0        0:    Use own PR

;*****
; Configure CAPCON and enable capture operation *
;*****
        SPLK    #1011110001010101b,CAPCON
                ; Capture control
* bit 15      1:    No action
* bit 14-13   01:   Enable Capture Us 1&2 and disable QEP
* bit 12      1:    Enable Capture U 3
* bit 11      1:    Enable Capture U 4
* bit 10      1:    GP Timer 3 is time base for Cap Us 3&4
* bit 9       0:    GP Timer 2 is time base for Cap Us 1&2
* bit 8       0:    No Capture U 4 event starts ADC
* bits 7-6    01:   Capture U 1 detects rising edge
* bits 5-4    01:   Capture U 2 detects rising edge
* bits 3-2    01:   Capture U 3 detects rising edge
* bits 1-0    01:   Capture U 4 detects rising edge
;*****
; Configure T3CON *
;*****
        SPLK    #1001000011000010b,T3CON
                ; Set GP Timer 3 control
* bit 15      1:    FREE = 1
* bit 14      0:    SOFT = 0
* bits 13-12  010:  continuous-up count mode
* bits 10-8   000:  Prescaler = /1
* bit 7       1:    Use Timer ENABLE of GP Timer 1
* bit 6       1:    Timer (counting operation) enabled
* bits 5-4    00:   Select internal CLK
* bits 3-2    00:   Load GP Timer comp register on underflow
* bit 1       1:    GP Timer compare enabled
* bit 0       0:    Use own PR
;*****
; Configure T1CON and start GP Timers 1&3 *
;*****
        SPLK    #1001000001000010b,T1CON
                ; Set GP Timer 1 control
                ; Start GP Timers 1&2
* bit 15      1:    FREE = 1
* bit 14      0:    SOFT = 0
* bits 13-12  010:  continuous-up count mode
* bits 10-8   000:  Prescaler = /1
* bit 7       0:    reserved

```

Example 6–8. Initialization Routine for Capture Units (Continued)

```

* bit 6          1:    Timer (counting operation) enabled
* bits 5-4      00:    Select internal CLK
* bits 3-2      00:    Load GP Timer comp register on underflow
* bit 1         1:    GP Timer compare enabled
* bit 0         0:    reserved
;*****
; Read captured values and calculate the difference      *
;*****
                LAR   AR2,#01eh          ; Loop 16 times
                MAR   *,AR1             ; ARP<=AR1 point to result log
LOOP
                LACC  CAPFIFO           ; Read Capture FIFO status
                AND   #0000001000000000b ; Got >=2 entries in FIFO 1
                                                ; No, bypass
                BCND  LOOP,EQ
                LACC  FIFO1             ; Read Capture FIFO 1 1st entry
                SACL  *+                 ; Save
                LACC  FIFO1             ; 1st entry-2nd entry
                SACL  *-                 ; Save
                SUB   *+                 ; Calculate diff
                MAR   *+,AR3            ; Adjust pointer and point to diff log
                SACL  *+,AR2            ; Save diff and point to loop control
DLOOP          B     DLOOP

```

6.13 Quadrature Encoder Pulse (QEP) Circuit

The event manager module has a quadrature encoder pulse (QEP) circuit. The QEP circuit, when enabled, decodes and counts the quadrature-encoded input pulses on pins CAP1/QEP1 and CAP2/QEP2. The QEP circuit can be used to interface with an optical encoder to get position and speed information for a rotating machine.

6.13.1 QEP Pins

The two QEP input pins are shared between capture units 1 and 2 and the QEP circuit. CAPCON bits must be properly configured to enable the QEP circuit and disable capture units 1 and 2. This assigns the two associated input pins for use by the QEP circuit.

6.13.2 QEP Circuit Time Base

The time base for the QEP circuit can be provided by GP timers 2, 3, or 2 and 3 together as a 32-bit timer. The selection is made by configuration of T2CON or T3CON bits. The selected GP timer or 32-bit timer must be set in directional up/down counting mode with the QEP circuit as the clock source. Figure 6–29 shows a block diagram of a QEP circuit.

Figure 6–29. Quadrature Encoder Pulse (QEP) Circuit Block Diagram

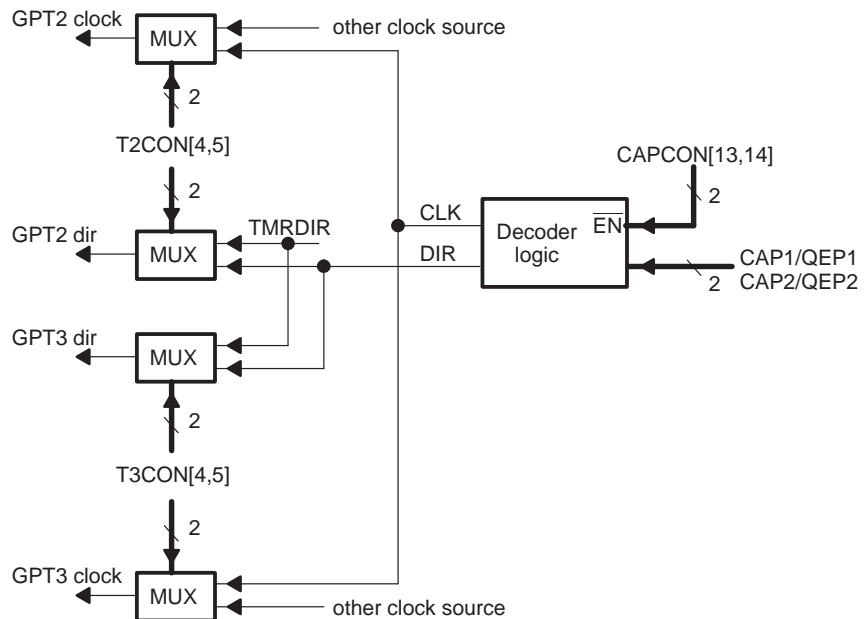

6.13.3 QEP Decoding

Quadrature-encoded pulses consist of two sequences of pulses with variable frequencies and fixed phase shifts of a quarter of a period (90 degrees). When generated by an optical encoder on a motor shaft, the direction of rotation of the motor can be determined by detecting which of the two sequences leads. The angular position and speed can be determined by the pulse count and pulse frequency. Below is a description of the QEP circuit and an example of quadrature-encoded pulses.

QEP Circuit

The direction-detection logic of the QEP circuit determines which sequence leads. It then generates a direction signal as the direction input to the selected timer. The selected timer counts up if the CAP1/QEP1 input is the leading sequence and counts down if CAP2/QEP2 is the leading sequence.

Both edges of the pulses of the two quadrature-encoded inputs are counted by the QEP circuit. Therefore, the frequency of the QEP generated clock (quadrature clock) to the GP timer is four times that of each input sequence. This quadrature clock is connected to the clock input of the selected GP timer or 32-bit timer.

QEP Decoding Example

Figure 6–30 shows an example of quadrature-encoded pulses and the determined counting direction and clock.

Figure 6–30. Quadrature Encoded Pulses and Decoded Timer Clock and Direction

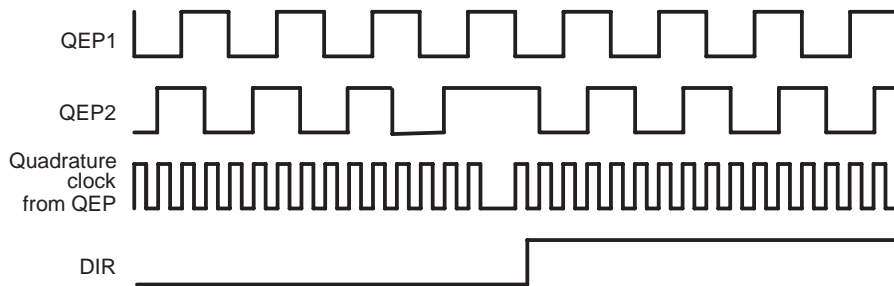

6.13.4 QEP Counting

The selected GP timer always starts counting from its current value in the counter. A desired value can be loaded to the selected GP timer counter prior to enabling the QEP operation. When the QEP circuit is selected as the clock source, the selected timer ignores the TMRDIR and TMRCLK input pins. Below are descriptions of the GP timer counting and interrupt operations when the QEP circuit is used as clock.

GP Timer Counting Mode in QEP Operation

It is important to note that the directional up/down counting mode of the selected GP timer with a QEP circuit as the clock is different from the normal directional up/down counting mode. When the timer selected for QEP operation counts up to the period value, the GP timer continues counting up until the counting direction changes. When the timer counts up to FFFFh (or FFFF FFFFh), it rolls over to 0 if the counting direction is up. When the timer counts down to 0, the GP timer rolls over to FFFFh (or FFFF FFFFh) if the counting direction is down.

GP Timer Interrupt and Associated Compare Outputs in QEP Operation

Period, underflow, overflow, and compare interrupt flags for the GP timer with the QEP circuit as the clock are generated on respective matches. No transitions, however, happen on the compare output of the selected GP timer or any other compare unit that uses this timer as its time base.

6.13.5 Register Setup for the QEP Circuit

To start the QEP circuit:

- 1) Configure T2CON or T3CON to set GP timers 2, 3, or 2 and 3 in directional up/down or 32-bit mode with the QEP circuits as clock source. Enable the selected timer.
- 2) Configure CAPCON to enable the QEP circuit.

Note:

When appropriate, desired values can be loaded into the selected GP timer counter, period, and compare registers.

Example 6–9 shows an initialization routine for QEP operation.

Example 6–9. Register Setup for a QEP Circuit

```

;*****
; The following section of codes initializes QEP operation *
;*****
LDPK #232 ; DP => EV Registers
;*****
; Configure GPTCON
;*****
SPLK #1110001011110000b, CAPCON ; Set GP Timer control
;
;
;
* bits 0-1 00: No detection for Capture 4
* bits 2-3 00: No detection for Capture 3
* bits 4-5 11: Capture 2 detects both edges
* bits 6-7 11: Capture 1 detects both edges
* bit 8 0: No Capture 4 event starts ADC
* bit 9 1: GP Timer 3 is time base for Capture 1 & 2
* bit 10 0: GP Timer 2 is time base for Capture 3 & 4
* bit 11 0: Disable Capture 4
* bit 12 0: Disable Capture 3
* bits 13-14 11: Enable QEP
* bit 15 1: No action
;*****
; Configure counter register T3CNT *
;*****
SPLK #0000h, T3CNT
;*****
; Configure period register T3PER *
;*****
SPLK #00FFh, T3PER
;*****
; Configure T3CON and start GP Timer 3 *
;*****
SPLK #1001100001110000b, T3CON ; Set GP Timer 3 control
;
;
;
* bit 0 0: Use own PR
* bit 1 0: GP Timer compare disabled
* bits 2-3 00: Load GP Timer comp register on underflow
* bits 4-5 11: Select QEP
* bit 6 1: Timer (counting operation) enabled
* bit 7 0: Use own Timer ENABLE
* bits 8-10 000: Prescaler = /1(During QEP,prescaler is always 1)
* bits 11-13 011: Directional up/down mode for QEP
* bit 14 0: SOFT = 0
* bit 15 1: FREE = 1

```

6.14 Event Manager (EV) Interrupts

EV interrupts are generated by the EV module and transmitted to the CPU through interrupt inputs.

6.14.1 Organization of TMS320C240 Interrupts

EV interrupts consists of maskable and nonmaskable external interrupts. Below are descriptions of the organization and handling of core interrupts.

'C2xx Core Interrupt Organization

The 'C2xx core (the CPU) has six maskable (INT1–INT6) and one nonmaskable (NMI) external interrupts. Priority decreases from INT1 to INT6, with NMI having the highest priority and INT6 having the lowest priority. Each interrupt corresponds to a bit in the core interrupt flag register (IFR), and each maskable interrupt corresponds to a bit in the core interrupt mask register (IMR). A maskable interrupt is masked (does not generate an interrupt to the core) when the corresponding bit in IMR is 0. The core also has a global interrupt mask bit (INTM) in status register ST0. When INTM is set to 1, all maskable interrupts are masked.

'C2xx Core Interrupt Handling

When a transition from high to low occurs on an interrupt input to the core, the corresponding interrupt flag bit in IFR is set to 1. An interrupt to the core is generated by this flag if:

- It is unmasked
- Global interrupts are allowed (INTM = 0)
- No other unmasked interrupts of higher priority are pending (that is, no other unmasked interrupt flags of higher priority are set).

The flag is cleared by hardware once the interrupt request is taken by the core. An interrupt flag can also be cleared by user software writing a 1 to the bit.

6.14.2 EV Interrupt Requests and Services

The following paragraphs describe how interrupt requests are grouped, what happens after an interrupt event occurs in the EV module, how the interrupt vector is read, and how the accumulator handles the interrupt.

Interrupt Groups

EV interrupt events are organized into three groups: EV interrupt groups A, B, and C. EV interrupt group A generates interrupt requests to the core on INT2. EV interrupt groups B and C generate interrupt requests to the core on INT3 and INT4, respectively. Table 6–10 shows all EV interrupts, their priorities, and groupings. There is an interrupt flag register for each EV interrupt group: EVIFRA, EVIFRB, and EVIFRC. There is also an interrupt mask register for each group: EVIMRA, EVIMRB, and EVIMRC. A flag in EVIFRx ($x = A, B, \text{ or } C$) is masked if the corresponding bit in EVIMRx is 0.

There is an 8-bit interrupt vector register (EVIVRx, $x = A, B, \text{ or } C$) associated with each EV interrupt group. The corresponding interrupt vector register can be read from an interrupt service routine (ISR) when an interrupt request generated by the interrupt group is accepted by the core. The value (vector) in the interrupt vector register identifies which pending and unmasked interrupt in the group has the highest priority.

Table 6–10. Event Manager Interrupts

Group	Interrupt	Priority Within Group	Vector (ID)	Description/Source
A	PDPINT	1 (highest)	0020h	Power drive protection interrupt
	CMP1INT	2	0021h	Full compare unit 1 compare interrupt
	CMP2INT	3	0022h	Full compare unit 2 compare interrupt
	CMP3INT	4	0023h	Full compare unit 3 compare interrupt
	SCMP1INT	5	0024h	Simple compare unit 1 compare interrupt
	SCMP2INT	6	0025h	Simple compare unit 2 compare interrupt
	SCMP3INT	7	0026h	Simple compare unit 3 compare interrupt
	T1PINT	8	0027h	GP timer 1 period interrupt
	T1CINT	9	0028h	GP timer 1 compare interrupt
	T1UFINT	10	0029h	GP timer 1 underflow interrupt
T1OFINT	11 (lowest)	002Ah	GP timer 1 overflow interrupt	
B	T2PINT	1 (highest)	002Bh	GP timer 2 period interrupt
	T2CINT	2	002Ch	GP timer 2 compare interrupt
	T2UFINT	3	002Dh	GP timer 2 underflow interrupt
	T2OFINT	4	002Eh	GP timer 2 overflow interrupt
	T3PINT	5	002Fh	GP timer 3 period interrupt
	T3CINT	6	0030h	GP timer 3 compare interrupt
	T3UFINT	7	0031h	GP timer 3 underflow interrupt
	T3OFINT	8 (lowest)	0032h	GP timer 3 overflow interrupt
C	CAP1INT	1 (highest)	0033h	Capture unit 1 interrupt
	CAP2INT	2	0034h	Capture unit 2 interrupt
	CAP3INT	3	0035h	Capture unit 3 interrupt
	CAP4INT	4 (lowest)	0036h	Capture unit 4 interrupt

Interrupt Generation

When an interrupt event occurs in the EV module, the corresponding interrupt flag in one of the EV interrupt flag registers is set to 1. An interrupt request is generated to the CPU by an EV interrupt group if an interrupt flag is set and unmasked in the interrupt group at the EV level, and the corresponding interrupt to the CPU is unmasked at the CPU level.

Interrupt Vectors

The interrupt vector of an EV interrupt group must be read after an interrupt request to the core is generated by the group. When this occurs, the interrupt vector (ID) corresponding to the interrupt flag with the highest priority among the set flags is loaded into the accumulator. The flag is cleared when its interrupt vector is read. However, an interrupt flag can also be cleared by writing a 1 directly to the interrupt flag bit.

A 0 is returned when the EV interrupt vector register of a group is read and no interrupt flags in the group are set and unmasked. This keeps stray interrupts from being identified as EV interrupts.

Clearing Interrupt Flags in EVIFx

When more than one interrupt from an interrupt group exists, the interrupt flags in EVIFx should be cleared only by reading the EVIRx register. Reading EVIRx automatically clears EVIFx flags. If EVIFx is manually cleared, future interrupt generations will be affected.

Interrupt Handling

After an EV interrupt request is received, the EVIVRx can be read into the accumulator and shifted left by one or more bits. Next, an offset address (start of an interrupt entrance table) can be added to the accumulator. A BACC instruction can be used to branch to an entry in a table. Another branch from the table branches to the interrupt service routine (ISR) for a specific source. This process causes a typical interrupt latency of 20 CPU cycles (25 if minimum context saving is required) from the time that an interrupt is generated to when the first instruction in the ISR for the specific source is reached. This latency can be reduced to a minimum of eight CPU cycles if only one interrupt is allowed in an EV interrupt group. If memory space is not a concern, the latency can be reduced to 16 CPU cycles without the requirement of allowing only one interrupt per EV interrupt group.

Note:

See Section 2.5 on page 2-27 for more interrupt related information.

6.14.3 EV Interrupt Flag Registers

The addresses of EV interrupt registers are shown in Table 6–5 on page 6-10. All of the registers are treated as 16-bit memory-mapped registers. The unused bits return 0 when read by software. Writing to unused bits has no effect. Since EVIFRx registers are readable, an occurrence of an interrupt event can be monitored by software polling the appropriate bit in EVIFRx when the interrupt is masked.

The three EV interrupt flag registers are: EV Interrupt Flag Register A (EVIFRA), EV Interrupt Flag Register B (EVIFRB), and EV Interrupt Flag Register C (EVIFRC).

EV Interrupt Flag Register A (EVIFRA)

Figure 6–31. EV Interrupt Flag Register A (EVIFRA) — Address 742Fh

15–11				10		9	8
Reserved				T1OFINT	T1UFINT	T1CINT	
				RW–0	RW–0	RW–0	
7	6	5	4	3	2	1	0
T1PINT	SCMP3INT	SCMP2INT	SCMP1INT	CMP3INT	CMP2INT	CMP1INT	PDPINT
RW–0	RW–0	RW–0	RW–0	RW–0	RW–0	RW–0	RW–0

Note: R = read access, W = write access, –0 = value after reset

Bits 15–11 **Reserved.** Reads return 0, and writes have no effect

Bit 10 **T1OFINT Flag.** GP timer 1 overflow interrupt

Read: 0 = Flag is reset
 1 = Flag is set
 Write: 0 = No effect
 1 = Reset flag

Bit 9 **T1UFINT.** GP timer 1 underflow interrupt

Read: 0 = Flag is reset
 1 = Flag is set
 Write: 0 = No effect
 1 = Reset flag

- Bit 8** **T1CINT.** GP timer 1 compare interrupt
- Read: 0 = Flag is reset
 1 = Flag is set
- Write: 0 = No effect
 1 = Reset flag
-
- Bit 7** **T1PINT.** GP timer 1 period interrupt
- Read: 0 = Flag is reset
 1 = Flag is set
- Write: 0 = No effect
 1 = Reset flag
-
- Bit 6** **SCMP3INT.** Simple compare 3 interrupt
- Read: 0 = Flag is reset
 1 = Flag is set
- Write: 0 = No effect
 1 = Reset flag
-
- Bit 5** **SCMP2INT.** Simple compare 2 interrupt
- Read: 0 = Flag is reset
 1 = Flag is set
- Write: 0 = No effect
 1 = Reset flag
-
- Bit 4** **SCMP1INT.** Simple compare 1 interrupt
- Read: 0 = Flag is reset
 1 = Flag is set
- Write: 0 = No effect
 1 = Reset flag
-
- Bit 3** **CMP3INT.** Full compare 3 interrupt
- Read: 0 = Flag is reset
 1 = Flag is set
- Write: 0 = No effect
 1 = Reset flag
-
- Bit 2** **CMP2INT Flag.** Full compare 2 interrupt
- Read: 0 = Flag is reset
 1 = Flag is set
- Write: 0 = No effect
 1 = Reset flag

Bit 1 **CMP1INT.** Full compare 1 interrupt

Read: 0 = Flag is reset
 1 = Flag is set
 Write: 0 = No effect
 1 = Reset flag

Bit 0 **PDPINT.** Power-drive protection interrupt

Read: 0 = Flag is reset
 1 = Flag is set
 Write: 0 = No effect
 1 = Reset flag

EV Interrupt Flag Register B (EVIFRB)

Figure 6–32. EV Interrupt Flag Register B (EVIFRB) — Address 7430h

15–8	7	6	5	4	3	2	1	0
Reserved	T3OFINT	T3UFINT	T3CINT	T3PINT	T2OFINT	T2UFINT	T2CINT	T2PINT
	RW–0	RW–0	RW–0	RW–0	RW–0	RW–0	RW–0	RW–0

Note: R = read access, W = write access, –0 = value after reset

Bits 15–8 **Reserved.** Reads return 0, and writes have no effect**Bit 7** **T3OFINT Flag.** GP timer 3 overflow interrupt

Read: 0 = Flag is reset
 1 = Flag is set
 Write: 0 = No effect
 1 = Reset flag

Bit 6 **T3UFINT.** GP timer 3 underflow interrupt

Read: 0 = Flag is reset
 1 = Flag is set
 Write: 0 = No effect
 1 = Reset flag

Bit 5 **T3CINT.** GP timer 3 compare interrupt

Read: 0 = Flag is reset
 1 = Flag is set
 Write: 0 = No effect
 1 = Reset flag

- Bit 4** **T3PINT.** GP timer 3 period interrupt
Read: 0 = Flag is reset
 1 = Flag is set
Write: 0 = No effect
 1 = Reset flag
- Bit 3** **T2OFINT.** GP timer 2 overflow interrupt
Read: 0 = Flag is reset
 1 = Flag is set
Write: 0 = No effect
 1 = Reset flag
- Bit 2** **T2UFINT.** GP timer 2 underflow interrupt
Read: 0 = Flag is reset
 1 = Flag is set
Write: 0 = No effect
 1 = Reset flag
- Bit 1** **T2CINT.** GP timer 2 compare interrupt
Read: 0 = Flag is reset
 1 = Flag is set
Write: 0 = No effect
 1 = Reset flag
- Bit 0** **T2PINT.** GP timer 2 period interrupt
Read: 0 = Flag is reset
 1 = Flag is set
Write: 0 = No effect
 1 = Reset flag

EV Interrupt Flag Register C (EVIFRC)

Figure 6–33. EV Interrupt Flag Register C (EVIFRC) — Address 7431h



Note: R = read access, W = write access, –0 = value after reset

Bits 15–4 **Reserved.** Reads return 0 and writes have no effect.

Bit 3 **CAP4INT Flag.** Capture 4 interrupt

Read: 0 = Flag is reset.
 1 = Flag is set
 Write: 0 = No effect
 1 = Reset flag

Bit 2 **CAP3INT.** Capture 3 interrupt

Read: 0 = Flag is reset
 1 = Flag is set
 Write: 0 = No effect
 1 = Reset flag

Bit 1 **CAP2INT.** Capture 2 interrupt

Read: 0 = Flag is reset
 1 = Flag is set
 Write: 0 = No effect
 1 = Reset flag

Bit 0 **CAP1INT.** Capture 1 interrupt

Read: 0 = Flag is reset
 1 = Flag is set
 Write: 0 = No effect
 1 = Reset flag

6.14.4 EV Interrupt Mask Registers

The three EV interrupt mask registers are: EV Interrupt Mask Register A (EVIMRA), EV Interrupt Mask Register B (EVIMRB), and EV Interrupt Mask Register C (EVIMRC).

EV Interrupt Mask Register A (EVIMRA)

Figure 6–34. EV Interrupt Mask Register A (EVIMRA) — Address 742Ch

15–11				10		9	8
Reserved				T1OFINT	T1UFINT	T1CINT	
				RW–0	RW–0	RW–0	
7	6	5	4	3	2	1	0
T1PINT	SCMP3INT	SCMP2INT	SCMP1INT	CMP3INT	CMP2INT	CMP1INT	PDPINT
RW–0	RW–0	RW–0	RW–0	RW–0	RW–0	RW–0	RW–0

Note: R = read access, W = write access, –0 = value after reset

Bits 15–11 **Reserved.** Reads return 0 and writes have no effect.

Bit 10 **T1OFINT**
 0 = Disable
 1 = Enable

Bit 9 **T1UFINT**
 0 = Disable
 1 = Enable

Bit 8 **T1CINT**
 0 = Disable
 1 = Enable

Bit 7 **T1PINT**
 0 = Disable
 1 = Enable

Bit 6 **SCMP3INT**
 0 = Disable
 1 = Enable

Bit 5	SCMP2INT 0 = Disable 1 = Enable
Bit 4	SCMP1INT 0 = Disable 1 = Enable
Bit 3	CMP3INT 0 = Disable 1 = Enable
Bit 2	CMP2INT 0 = Disable 1 = Enable
Bit 1	CMP1INT 0 = Disable 1 = Enable
Bit 0	PDPINT 0 = Disable 1 = Enable

EV Interrupt Mask Register B (EVIMRB)

Figure 6–35. EV Interrupt Mask Register B — Address 742Dh

15–8	7	6	5	4	3	2	1	0
Reserved	T3OFINT	T3UFINT	T3CINT	T3PINT	T2OFINT	T2UFINT	T2CINT	T2PINT
	RW–0	RW–0	RW–0	RW–0	RW–0	RW–0	RW–0	RW–0

Note: R = read access, W = write access, –0 = value after reset

Bits 15–8 **Reserved.** Reads return 0, and writes have no effect

Bit 7 **T3OFINT**
 0 = Disable
 1 = Enable

Bit 6 **T3UFINT**
 0 = Disable
 1 = Enable

Bit 5 **T3CINT**
 0 = Disable
 1 = Enable

Bit 4 **T3PINT**
 0 = Disable
 1 = Enable

Bit 3 **T2OFINT**
 0 = Disable
 1 = Enable

Bit 2 **T2UFINT**
 0 = Disable
 1 = Enable

Bit 1 **T2CINT**
 0 = Disable
 1 = Enable

Bit 0 **T2PINT**
 0 = Disable
 1 = Enable

EV Interrupt Mask Register C (EVIMRC)

Figure 6–36. EV Interrupt Mask Register C — Address 742Eh



Note: R = read access, W = write access, –0 = value after reset

Bits 15–4 **Reserved.** Reads return 0, and writes have no effect

Bit 3 **CAP4INT**
 0 = Disable
 1 = Enable

Bit 2 **CAP3INT**
 0 = Disable
 1 = Enable

Bit 1 **CAP2INT**
 0 = Disable
 1 = Enable

Bit 0 **CAP1INT**
 0 = Disable
 1 = Enable

6.14.5 EV Interrupt Vector Registers

The three EV interrupt vector registers are: EV Interrupt Vector Register A (EVIVRA), EV Interrupt Vector Register B (EVIVRB), and EV Interrupt Vector Register C (EVIVRC).

EV Interrupt Vector Register A (EVIVRA)

Figure 6–37. EV Interrupt Vector Register A (EVIVRA) — Address 7432h

15	14	13	12	11	10	9	8	7	6	5	4	3	2	1	0
0	0	0	0	0	0	0	0	0	0	D5	D4	D3	D2	D1	D0
R–0	R–0	R–0	R–0	R–0	R–0	R–0	R–0	R–0	R–0	R–0	R–0	R–0	R–0	R–0	R–0

Note: R = read access, –0 = value after reset

Bits 15–6 **Reserved.** Reads return 0, and writes have no effect

Bits 5–0 **D5–D0.** Vector (ID) of the interrupt flag that has the highest priority among the set and unmasked interrupt flags of EVIFRA; 0 if no interrupt flag is set and unmasked in EVIFRA

EV Interrupt Vector Register B (EVIVRB)

Figure 6–38. EV Interrupt Vector Register B (EVIVRB) — Address 7433h

15	14	13	12	11	10	9	8	7	6	5	4	3	2	1	0
0	0	0	0	0	0	0	0	0	0	D5	D4	D3	D2	D1	D0
R–0	R–0	R–0	R–0	R–0	R–0	R–0	R–0	R–0	R–0	R–0	R–0	R–0	R–0	R–0	R–0

Note: R = read access, –0 = value after reset

Bits 15–6 **Reserved.** Reads return 0, and writes have no effect

Bits 5–0 **D5–D0.** Vector (ID) of the interrupt flag that has the highest priority among the set and unmasked interrupt flags of EVIFRB; 0 if no interrupt flag is set and unmasked in EVIFRB

EV Interrupt Vector Register C (EVIVRC)*Figure 6–39. EV Interrupt Vector Register C (EVIVRC) — Address 7434h*

15	14	13	12	11	10	9	8	7	6	5	4	3	2	1	0
0	0	0	0	0	0	0	0	0	0	D5	D4	D3	D2	D1	D0
R–0	R–0	R–0	R–0	R–0	R–0	R–0	R–0	R–0	R–0	R–0	R–0	R–0	R–0	R–0	R–0

Note: R = read access, –0 = value after reset

Bits 15–6 **Reserved.** Reads return 0, and writes have no effect

Bits 5–0 **D5–D0.** Vector (ID) of the interrupt flag that has the highest priority among the set and unmasked interrupt flags of EVIFRC; 0 if no interrupt flag is set and unmasked in EVIFRC.

Dual 10-Bit Analog-to-Digital Converter (ADC) Module

The analog-to-digital converter (ADC) module used in the 'C240 is a dual 10-bit ADC. This chapter provides a general description of the ADC module, explains its operation, and shows its control and data registers.

Topic	Page
7.1 Dual 10-Bit ADC Overview	7-2
7.2 ADC Operation	7-4
7.3 ADC Registers	7-7

7.1 Dual 10-Bit ADC Overview

The ADC is a 10 bit string/capacitor converter with internal sample-and-hold circuitry. The ADC module consists of two 10-bit ADCs with two built in sample-and-hold circuits. A total of 16 analog input channels are available on the 'C240. Eight analog inputs are provided for each ADC unit via an eight to one analog multiplexer. The total conversion time for each ADC unit is approximately 6 μ s. (See the TMS320C240, TMS320F240 data sheet for exact specifications.) The reference voltage of the ADC module must be supplied from an external source. The upper and lower references can be set to any voltage less than or equal to 5 Vdc by connecting VREFHI and VREFLO to the appropriate reference voltages. The VCCA and VSSA pins must be connected to a 5 Vdc source and the analog ground, respectively.

The ADC module, shown in Figure 7–1, *ADC Module Block Diagram*, consists of the following:

- Eight analog inputs for each ADC module, for a total of 16 analog inputs
- Simultaneous measurement of two analog inputs using two ADC units
- Single or continuous conversion
- Conversion can be started by software, internal event, and/or external event
- VREFHI and VREFLO (high- and low-voltage) reference inputs
- Analog to digital conversion block
- 2-level-deep digital result registers that contain the digital values of completed conversions
- Two programmable ADC module control registers
- Programmable prescaler select
- Interrupt or polled operation

Figure 7–1. ADC Module Block Diagram

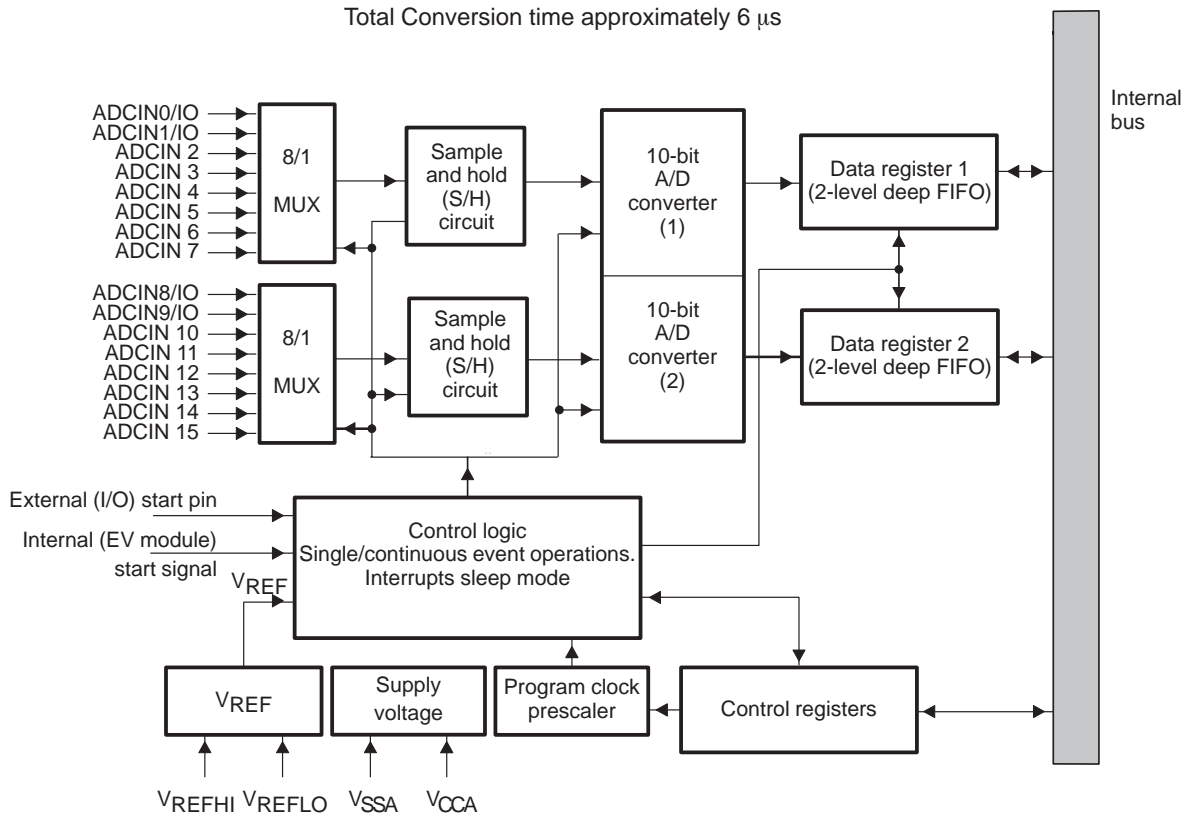

7.2 ADC Operation

The digital result of the conversion process for the 10-bit ADC is approximated by the following equation:

$$\text{Digital result} = 1023 \times \frac{\text{Input analog voltage} - V_{REFLO}}{V_{REFHI} - V_{REFLO}}$$

7.2.1 ADC Module Pin Description

The ADC module provides 20 pins that can interface to external circuitry. Sixteen of these pins, ADCIN0–ADCIN15, are for the analog inputs. Two pins, V_{REFHI} and V_{REFLO}, are the analog reference-voltage pins.

The analog supply pins, V_{CCA} and V_{SSA} (which are separate from any digital voltage supply pins), use standard noise reduction techniques to ensure accurate conversion. This means that analog power lines connected to V_{CCA} and V_{SSA} are made as short as possible and the two lines are decoupled properly.

Analog voltage input pins ADCIN0 through ADCIN7 belong to the first ADC module and ADCIN8 through ADCIN15 belong to the second ADC module. Analog inputs ADCIN0 and ADCIN1 of the first module and analog inputs ADCIN8 and ADCIN9 of the second module are multiplexed with digital I/O. By properly programming the system module, these four analog input pins (ADCIN0, ADCIN1, ADCIN8, and ADCIN9) can be used as digital I/O. The accuracy of these four pins; however, is lower than that of the dedicated analog input pins (ADCIN2 – ADCIN7, and ADCIN10 – ADCIN15).

7.2.2 ADC Module Operational Modes

The operating modes of the ADC module can:

- Sample and convert two input channels (one for each ADC unit) simultaneously
- Perform single or continuous S/H and conversion operations
- Use two 2-level-deep FIFO result registers for ADC units 1 and 2
- Start operation by software instruction, external signal transition on a device pin, or by the EV events on each of the GP timer/compare outputs and the capture 4 pins

- ❑ Write to those bits in the ADC control registers that are double buffered with shadow registers without affecting the ongoing conversion process. The newly written bit values first go to a shadow register instead of the active register. This new bit configuration is automatically loaded from the shadow register to the active register only after completion of the present conversion process. The next conversion process is then determined by the new bit configuration.
- ❑ Set an interrupt flag and generate an interrupt at the end of each conversion, if the interrupt is unmasked/enabled.

If a third conversion is completed without reading the FIFO, the data from the first conversion is lost.

7.2.3 Analog Signal Sampling/Conversion

The individual ADC module performs input sampling in one, and conversion in four-and-a-half ADC prescaled clock cycles for a total sample/conversion in five-and-a-half ADC clock cycles. The architecture of the ADC module requires the sample/conversion time to be 5.5 μ s or greater to ensure an accurate conversion. This relationship between the number of ADC clock cycles required (five-and-a-half) and the minimum of 5.5 μ s must be met at all system clock (SYSCLK) frequencies to ensure accurate conversion. Since the system clock may operate at frequencies which violate this relationship, a prescaler is provided with the ADC modules that allows the module to maintain optimal performance as the DSP clock (CPUCLK) varies between applications. You should select the ADC prescaler value such that the total ADC sample/conversion time is greater than or equal to 5.5 μ s. The prescaler value must satisfy the following formula:

$$\text{SYSCLK clock period} \times \text{prescaler value} \times 5.5 \geq 5.5 \mu\text{s}$$

Table 7–1. Sample Clock Frequencies and Appropriate Prescaler Values

ADCTRL2 Bits			Prescale Value
Bit 2	Bit 1	Bit 0	
0	0	0	4
0	0	1	6
0	1	0	8
0	1	1	10
1	0	0	12
1	0	1	16
1	1	0	20
1	1	1	32

Note:

The ADC sample/conversion times provided above do not include the delays from start of conversion to sample, or from end of conversion to FIFO load. For exact specifications, refer to the TMS320C240, TMS320F240 data sheet.

7.3 ADC Registers

This section provides a bit-by-bit description of the control registers used to program the ADC. Table 7–2 lists the addresses of the ADC registers.

Table 7–2. Addresses of ADC Registers

Address	Register	Name	Described in	
			Section	Page
7032h	ADCTRL1	ADC control register 1	7.3.1	7-7
7034h	ADCTRL2	ADC control register 2	7.3.2	7-10
7036h	ADCFIFO1	ADC 2-level deep data register FIFO for ADC 1	7.3.3	7-13
7038h	ADCFIFO2	ADC 2-level deep data register FIFO for ADC 2	7.3.3	7-13

7.3.1 ADC Control Register 1 (ADCTRL1)

ADC control register 1 controls the start of conversion, the ADC module enable/disable function, the interrupt enable, and the end of conversion.

Figure 7–2. ADC Control Register 1 (ADCTRL1) — Address 7032h

15	14	13	12	11	10	9	8
Soft	Free	ADCIMSTART	ADC2EN	ADC1EN	ADCCONRUN	ADCINTEN	ADCINTFLAG
RW–0	RW–0	RW–0	SRW–0	SRW–0	SRW–0	RW–0	RW–0
7	6–4		3–1			0	
ADCEOC	ADC2CHSEL			ADC1CHSEL			ADCSOC
R–0	SRW–0			SRW–0			SRW–0

Note: R = read access, W = write, S = shadowed, –0 = value after reset

- Bit 15** **Soft.** Applicable only during emulation. This bit is not shadowed.
- 0 = Stop immediately when suspend-free (bit 14) = 0
 - 1 = Complete conversion before halting emulator
- Bit 14** **Free.** Applicable only during emulation. This bit is not shadowed.
- 0 = Operation is determined by suspend-soft (bit 15)
 - 1 = Keep running on emulator suspend
- Bit 13** **ADCIMSTART.** ADC start converting immediately. This bit is not shadowed.
- 0 = No action
 - 1 = Immediate start of conversion

- Bit 12** **ADC2EN.** Enable/disable bit for ADC2. This bit is shadowed. This bit can be written to while a conversion is occurring. The effect of writing to this bit is observed during the next conversion.
- 0 = ADC2 disabled. (No sample/hold/conversion can take place; data register FIFO1 does not change.)
 - 1 = ADC2 is enabled.
- Bit 11** **ADC1EN.** Enable/disable bit for ADC1. This bit is shadowed. This bit can be written to while a conversion is occurring. The effect of writing to this bit is observed during the next conversion.
- 0 = ADC1 disabled. (No sample/hold/conversion can take place; data register FIFO1 does not change.)
 - 1 = ADC1 is enabled.
- Bit 10** **ADCCONRUN.** This bit sets the ADC unit for continuous conversion mode. This bit is shadowed. This bit can be written to while a conversion is occurring. The effect of writing to this bit is observed during the next conversion.
- 0 = No action
 - 1 = Continuous conversion
- Bit 9** **ADCINTEN.** Enable interrupts. If the ADCINTEN bit is set, an interrupt is requested when the ADCINTFLAG is set. This bit is cleared on reset.
- Bit 8** **ADCINTFLAG.** ADC interrupt flag bit. This bit indicates if an interrupt event has occurred. Writing a 1 to ADCINTFLAG clears the bit. This bit is not shadowed.
- 0 = No interrupt event occurred.
 - 1 = An interrupt event occurred.
- Bit 7** **ADCEOC.** This bit indicates the status of the ADC conversion. This bit is not shadowed.
- 0 = End of conversion
 - 1 = Conversion is in progress

Bits 6–4 **ADC2CHSEL.** Selects channels for ADC2. This bit is shadowed. This bit can be written to while a previous conversion is occurring. The effect of writing to this bit is observed during the next conversion.

000 = Channel 8
001 = Channel 9
010 = Channel 10
011 = Channel 11
100 = Channel 12
101 = Channel 13
110 = Channel 14
111 = Channel 15

Bits 3–1 **ADC1CHSEL.** Selects channels for ADC1. This bit is shadowed. It can be written while a previous conversion is occurring. The effect of writing to this bit is observed during the next conversion.

000 = Channel 0
001 = Channel 1
010 = Channel 2
011 = Channel 3
100 = Channel 4
101 = Channel 5
110 = Channel 6
111 = Channel 7

Bit 0 **ADCSOC.** ADC start of conversion (SOC) bit. This bit is shadowed. It can be written to while a previous conversion is occurring. The effect of writing to this bit is observed during the next conversion.

0 = No action
1 = Start converting

Note:

Either channel 1 or channel 2 must be enabled before a conversion can start.

7.3.2 ADC Control Register 2 (ADCTRL2)

Figure 7–3. ADC Control Register 2 (ADCTRL2) — Address 7034h

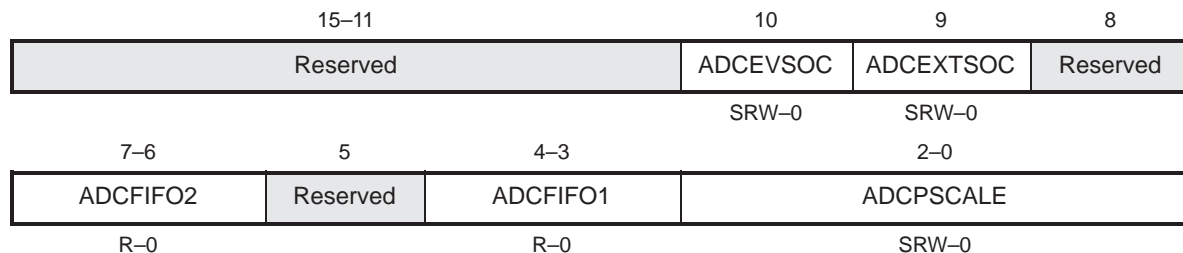

Note: R = read access, W = write, S = shadowed, –0 = value after reset

Bits 15–11 **Reserved.** Reads are indeterminate; writes have no effect.

Bit 10 **ADCEVSOC.** Event manager SOC mask bit. When set, the ADC conversion can be synchronized with an event manager signal. The event manager can start a conversion, depending on the outcome of GPT 1, 2, or 3, and Capture 4 events. See the description of GPTCON on page 6-42 and CAPCON on page 6-82. This bit is shadowed and functions as any other previously described shadowed bit.

- 0 = Mask ADCEVSOC (disable conversion start by EV)
- 1 = Enable conversion start by EV

Bit 9 **ADCEXTSOC.** External signal mask bit. When set, the ADC conversion can be synchronized with an external signal. ADC conversion starts with the rising edge of the external signal. This bit is shadowed.

- 0 = Mask ADCEXTSOC (disable conversion start by ADCSOC pin)
- 1 = Enable conversion start by ADCSOC pin

Bit 8 **Reserved.** Reads are indeterminate, and writes have no effect.

Bits 7–6 **ADCFIFO2.** Data register FIFO2 status. These two bits indicate ADC2 FIFO status. Two conversion results can be stored before performing a read operation. If a third conversion is made after two conversions, the oldest result is lost. These bits are not shadowed.

00 = FIFO2 is empty.

01 = FIFO2 has one entry.

10 = FIFO2 has two entries.

11 = FIFO2 had two entries and another entry was received; the first entry was lost.

Bit 5 **Reserved.** Reads are indeterminate and writes have no effect.

Note:

The start of convert signals are ORed together. When both convert signals are asserted simultaneously, the first signal starts a conversion and when that conversion is finished, the second SOC signal causes a second conversion to begin.

Bits 4–3 **ADCFIFO1.** Data register FIFO1 status. These two bits indicate ADC1 FIFO status. Two conversion results can be stored before performing any read operations. If a third conversion is made after two conversions, the oldest result is lost. These bits are not shadowed.

00 = FIFO1 is empty.

01 = FIFO1 has one entry.

10 = FIFO1 has two entries.

11 = FIFO1 had two entries and another entry was received; the first entry was lost.

Bits 2–0 **ADCPSCALE.** ADC input clock prescaler. These bits define the ADC clock prescaler. Sample prescaler times are explained in section 7.2.3, *Analog Signal Sampling/Conversion*, on page 7-6. See the following table for prescaler values.

ADCPSCALE Bits			Prescale Value
Bit 2	Bit 1	Bit 0	
0	0	0	4
0	0	1	6
0	1	0	8
0	1	1	10
1	0	0	12
1	0	1	16
1	1	0	20
1	1	1	32

7.3.3 ADC Digital Result Registers

The ADC digital result registers contain a 10-bit digital result following conversion of the analog input. These are read-only registers. On reset, they are cleared. The results are stored in a 2-level FIFO. This provides the flexibility of converting two variables before reading them from the data registers. However, if a third conversion is made when there are two unread values in the FIFO, the first converted value is lost.

Figure 7–4. ADC Data Registers FIFO1 (ADCFIFO1) — Address 7036h and FIFO2 (ADCFIFO2) — Address 7038h

15	14	13	12	11	10	9	8	7	6	5	4	3	2	1	0
D9	D8	D7	D6	D5	D4	D3	D2	D1	D0	0	0	0	0	0	0
MSB										LSB					

Bits 15–6 **D9–D0.** Actual 10-bit converted data

Bits 5–0 **Reserved.** Always read as 0

Example 7–1. ADC Initialization Example

```

;-----
; Set up ADC Module of TMS320F240
;-----
      LDP#224    ;DP = 224 Data Page for ADC Registers

      SPLK    #1000100100000000b,ADCTRL1
;
;          |||
;          5432109876543210
;ADCTRL1 - ADC Control Register 1
;Bit 15    (1) Suspend-SOFT - Complete Conv before halting emulator
;Bit 14    (0) Suspend-FREE - Operations is determined by Suspend-SOFT
;Bit 13    (0) ADCIMSTART - Immediate Start of Conversion is disabled
;Bit 12    (0) ADC2EN - ADC2 is disabled.
;Bit 11    (1) ADC1EN - ADC1 is enabled.
;Bit 10    (0)   ADCCONRUN - ADC Continuous Conversion Mode is disabled
;Bit 9     (1) ADCINTEN - Enable ADC Interrupt
;Bit 8     (1) ADCINTFLAG - ADC Interrupt Flag
;Bit 7     (0) ADCEOC - End of Conversion Bit  READ ONLY
;Bits 6-4  (000) ADC2CHSEL - ADC2 Channel Select
;Bits 3-1  (000) ADC1CHSEL - ADC1 Channel Select
;Bit 0    (0) ADCSOC - ADC Start of conversion bit

      SPLK    #0000000000000101b,ADCTRL2
;
;          |||
;          5432109876543210
;ADCTRL2 - ADC Control Register 2
;Bits 15-11 (00000)  Reserved
;Bit 10     (0) ADCEVSOC - Event Manager SOC mask bit is masked
;Bit 9      (0) ADCEXTSOC - External SOC mask bit is masked.
;Bit 8      (0) Reserved
;Bits 7-6   (00)   ADCFIFO1 - Data Register FIFO1 Status  READ ONLY
;Bit 5      (0) Reserved
;Bits 4-3   (00)   ADCFIFO2 - Data Register FIFO2 Status  READ ONLY
;Bits 2-0   (101) ADCPSCALE - ADC Input Clock Prescaler
;
;          Prescale Value 16
;          SYSCLK Period = 0.1u sec
;          0.1u sec x 16 x 6=9.6u sec >= 6u sec

```

Serial Communications Interface (SCI) Module

The programmable serial communications interface (SCI) module supports digital communications between the CPU and other asynchronous peripherals that use the standard NRZ (nonreturn-to-zero) format. This chapter describes the architecture, functions, and programming of the SCI module.

Topic	Page
8.1 SCI Overview	8-2
8.2 SCI Programmable Data Format	8-8
8.3 SCI Multiprocessor Communication	8-9
8.4 SCI Communication Format	8-14
8.5 SCI Port Interrupts	8-17
8.6 SCI Control Registers	8-19
8.7 SCI Initialization Example	8-34

8.1 SCI Overview

The SCI transmits and receives serial data, one bit at a time, at a programmable bit rate. The SCI's receiver and transmitter are double buffered, and each has its own separate enable and interrupt bits. Both may be operated independently or simultaneously in the full-duplex mode.

To ensure data integrity, the SCI checks data that has been received for break detection, parity, overrun, and framing errors. The speed of the bit rate (baud) is programmable to over 64K different speeds through a 16-bit baud-select register.

Note: Register Bit Notation, 8-Bit Peripheral

For convenience, references to a bit in a register are abbreviated using the register name followed by a period and the number of the bit. For example, the notation for bit 0 of SCI port control register 1 (SCIPC1) is SCIPC1.0.

This module is interfaced to the 16-bit peripheral bus as an 8-bit peripheral. Therefore, reads from bits 15–8 are undefined; writes to bits 15–8 have no effect.

8.1.1 SCI Physical Description

The SCI module, shown in Figure 8–1, *SCI Block Diagram*, on page 8-4 contains the following key features:

- Two I/O pins:
 - SCIRXD (SCI receive data input)
 - SCITXD (SCI transmit data output)
- Programmable bit rates to over 64K different speeds through a 16-bit baud select register
 - Range at 10-MHz SYSCLK: 19.07 bps to 625.0 kbps
 - Number of bit rates: 64K
- Programmable data-word length from one to eight bits
- Programmable stop-bits of either one or two bits in length
- Internally generated serial clock
- Four error detection flags:
 - Parity error
 - Overrun error
 - Framing error
 - Break detect

- Two wake-up multiprocessor modes that can be used with either communication format:
 - Idle-line wake-up
 - Address-bit wake-up
- Half- or full-duplex operation
- Double-buffered receive and transmit functions
- A transmitter and receiver operation that can be operated through interrupts or through polled operation because of the following status flags:
 - Transmitter: TXRDY flag (transmitter buffer register is ready to receive another character) and TX EMPTY flag (transmit shift register is empty)
 - Receiver: RXRDY flag (receive buffer register ready to receive another character), BRKDT flag (break condition occurred), and RX ERROR monitoring four interrupt conditions
- Separate enable bits for transmitter and receiver interrupts (except break)
- NRZ (non-return-to-zero) format

Figure 8–1. SCI Block Diagram

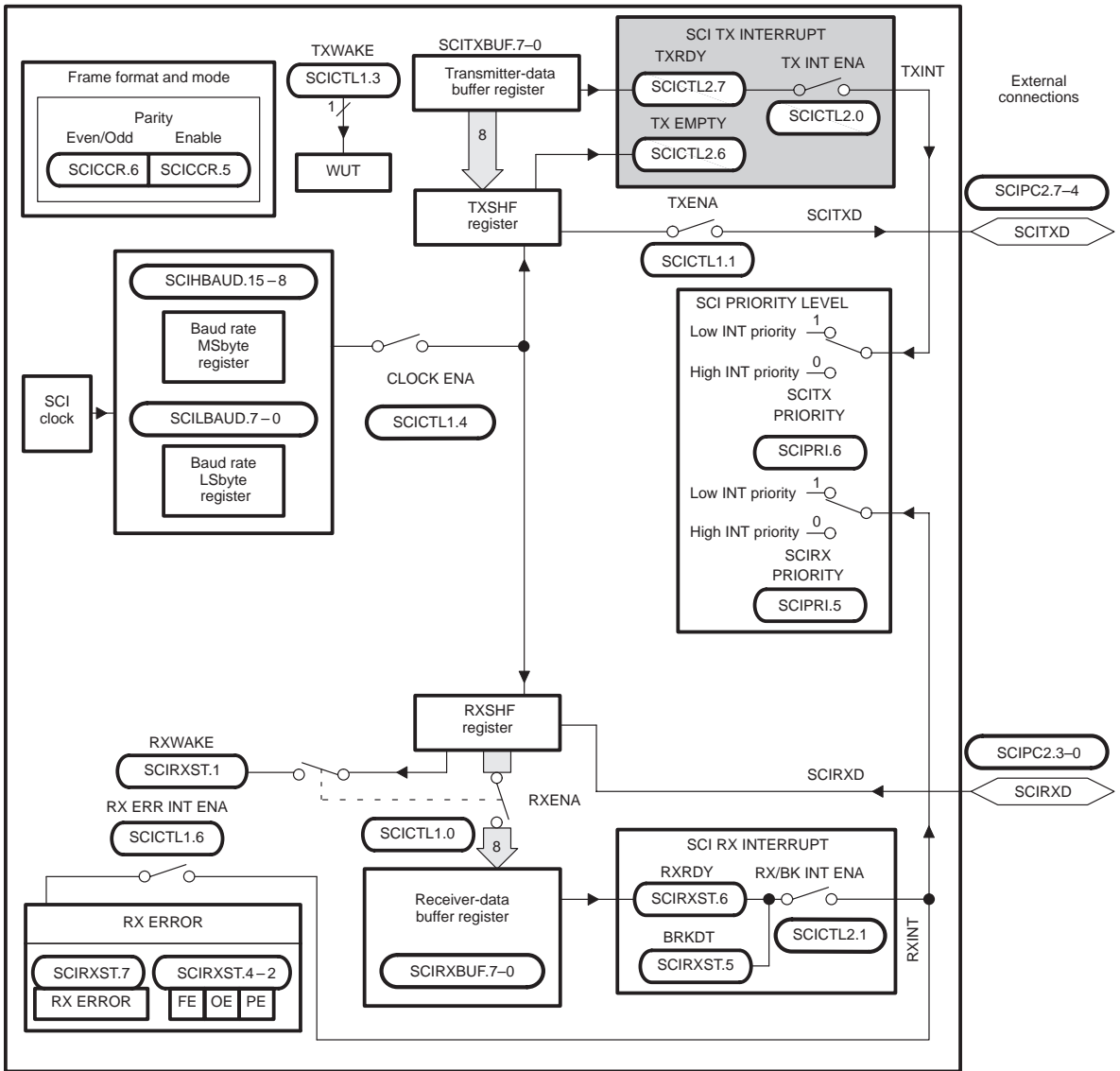

8.1.2 Architecture

The major elements used in the full duplex operation are shown in Figure 8–1, *SCI block Diagram*, on page 8-4 and include:

- ❑ A transmitter (TX) and its major registers:
 - SCITXBUF — transmitter data buffer register. Contains data (loaded by the CPU) to be transmitted
 - TXSHF — transmitter shift register. Loads data from SCITXBUF and shifts data onto the SCITXD pin, one bit at a time
- ❑ A receiver (RX) and its major registers:
 - RXSHF — receiver shift register. Shifts data in from SCIRXD pin, one bit at a time
 - SCIRXBUF — receiver data buffer register. Contains data to be read by the CPU. Data from a remote processor is loaded into RXSHF and then into SCIRXBUF and SCIRXEMU
- ❑ A programmable baud generator
- ❑ Data memory-mapped control and status registers

Note: The SCI receiver and transmitter can operate independently or simultaneously.

8.1.3 SCI Control Registers

The SCI control registers and their descriptions are shown below in Table 8–1. For more specific information, see Section 8.6, *SCI Control Registers*, on page 8-19.

Table 8–1. Addresses of SCI Registers

Address	Register	Name	Description	Described in	
				Section	Page
7050h	SCICCR	SCI communication control register	Defines the character format, protocol, and communications mode used by the SCI	8.6.1	8-20
7051h	SCICTL1	SCI control register 1	Controls the RX/TX and receiver error interrupt enable, TXWAKE and SLEEP functions, internal clock enable, and the SCI software reset	8.6.2	8-22
7052h	SCIHBAUD	SCI baud register, high bits	Stores the data (MSbyte) required to generate the bit rate	8.6.3	8-25
7053h	SCILBAUD	SCI baud register, low bits	Stores the data (LSbyte) required to generate the bit rate	8.6.3	8-25
7054h	SCICTL2	SCI control register 2	Contains the transmitter interrupt enable, the receiver-buffer/break interrupt enable, the transmitter ready flag, and the transmitter empty flag	8.6.4	8-26
7055h	SCIRXST	SCI receiver status register	Contains seven receiver status flags	8.6.5	8-27
7056h	SCIRXEMU	SCI emulation data buffer register	Contains data received for screen updates, principally used by the emulator	8.6.6	8-29
7057h	SCIRXBUF	SCI receiver data buffer register	Contains the current data from the receiver shift register	8.6.6	8-29
7058h	—	Reserved	Reserved		
7059h	SCITXBUF	SCI transmit data buffer register	Stores data bits to be transmitted by the SCITX	8.6.7	8-30
705Ah	—	Reserved	Reserved		
705Bh	—	Reserved	Reserved		
705Ch	—	Reserved	Reserved		
705Dh	—	Reserved	Reserved		
705Eh	SCIPC2	SCI port control register 2	Controls the SCIRXD and SCITXD pin functions	8.6.8	8-31
705Fh	SCIPRI	SCI priority control register	Contains the receiver and transmitter interrupt priority select bits and the emulator suspend enable bit	8.6.9	8-33

8.1.4 Multiprocessor and Asynchronous Communications Modes

The SCI has two multiprocessor protocols, the *idle-line* multiprocessor mode (see section 8.3.1 on page 8-10) and the *address-bit* multiprocessor mode (see section 8.3.2 on page 8-12). These protocols allow efficient data transfer between multiple processors.

The SCI offers the universal asynchronous receiver/transmitter (UART) communications mode for interfacing with many popular peripherals. The asynchronous mode (see section 8.4, *SCI Communication Format*, on page 8-14) requires two lines to interface with many standard devices such as terminals and printers that use RS-232-C formats. Data transmission characteristics include:

- One start bit
- One to eight data bits
- An even/odd parity bit or no parity bit
- One or two stop bits

8.2 SCI Programmable Data Format

SCI data, both receive and transmit, is in NRZ (non-return-to-zero) format. The NRZ data format, shown in Figure 8–2, consists of:

- One start bit
- One to eight data bits
- An even/odd parity bit (optional)
- One or two stop bits
- An extra bit to distinguish addresses from data (address-bit mode only)

The basic unit of data is called a character and is one to eight bits in length. Each character of data is formatted with a start bit, one or two stop bits, and optional parity and address bits. A character of data with its formatting information is called a frame and is shown in Figure 8–2.

Figure 8–2. Typical SCI Data Frame Formats

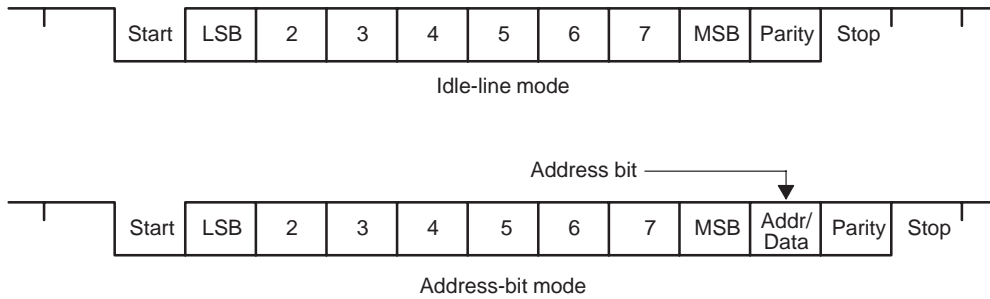

To program the data format, use the SCI communication control register (SCICCR) described in section 8.6.1 on page 8-20. The bits used to program the data format are listed in Table 8–2.

Table 8–2. Programming the Data Format Using SCICCR

Bit Name	Designation	Functions
SCI CHAR2–0	SCICCR.2–0	Selects the character (data) length (one to eight bits). Bit values are shown in Table 8–4 on page 8-21.
PARITY ENABLE	SCICCR.5	Enables the parity function if set to 1 or disables the parity function if cleared to 0
EVEN/ODD PARITY	SCICCR.6	If parity is enabled, selects odd parity if cleared to 0 or even parity when set to 1
STOP BITS	SCICCR.7	Determines the number of stop bits transmitted—one stop bit if cleared to 0 or two stop bits if set to 1

8.3 SCI Multiprocessor Communication

The multiprocessor communication format allows one processor to efficiently send blocks of data to other processors on the same serial link. On one serial line, there can be only one transfer (or transmitter) at a time.

The *first byte* of a block of information that the transmitter sends contains an *address byte*, that is read by all receivers. Only receivers with the correct address can be interrupted by the data bytes that follow the address byte. The receivers with an incorrect address remain uninterrupted until the next address byte.

All processors on the serial link set their SCI's SLEEP bit (SCICTL1.2) to 1 so that they are interrupted only when the address byte is detected. When a processor reads a block address that corresponds to the CPU's device address as set by your application software, the program must clear the SLEEP bit to enable the SCI to generate an interrupt on receipt of each data byte.

Although the receiver still operates when the SLEEP bit is 1, it does not set RXRDY, RXINT, or any of the receive error status bits to 1 unless the address byte is detected and the address bit in the received frame is a 1. The SCI does not alter the SLEEP bit; your software must alter the SLEEP bit.

A processor recognizes an address byte according to the multiprocessor mode. For example:

- ❑ The *idle-line mode* (section 8.3.1, *Idle-Line Multiprocessor Mode*, on page 8-10) leaves a quiet space before the address byte. This mode does not have an extra address/data bit and is more efficient than the address-bit mode for handling blocks that contain more than ten bytes of data. The idle-line mode should be used for typical nonmultiprocessor SCI communication.
- ❑ The *address-bit mode* (section 8.3.2 on page 8-12) adds an extra bit (address bit) into every byte to distinguish addresses from data. This mode is more efficient in handling many small blocks of data because, unlike the idle mode, it does not have to wait between blocks of data. However, at high transmit speeds, the program is not fast enough to avoid a 10-bit idle in the transmission stream.

The multiprocessor mode is software selectable via the ADDR/IDLE MODE bit (SCICCR.3). Both modes use the TXWAKE (SCICTL1.3), RXWAKE (SCIRXST.1), and the SLEEP flag bits (SCICTL1.2) to control the SCI transmitter and receiver features of these modes.

In both multiprocessor modes, the receipt sequence is:

- 1) At the receipt of an address block, the SCI port wakes up and requests an interrupt. (Bit RX/BK INT ENA—SCICTL2.1—must be enabled to request an interrupt.) It reads the first frame of the block, which contains the destination address.
- 2) A software routine is entered through the interrupt and checks the RXWAKE flag bit. If the RXWAKE bit is 1, the incoming byte is an address (otherwise, the byte is data) and this address byte is checked against its device address byte stored in memory.
- 3) If the check shows that the block is addressed to the DSP controller, the CPU clears the SLEEP bit and reads the rest of the block. If not, the software routine exits with the SLEEP bit still set and does not receive interrupts until the next block start.

8.3.1 Idle-Line Multiprocessor Mode

In the Idle-line multiprocessor protocol (ADDR/IDLE MODE bit = 0), the blocks are separated by a longer idle time between blocks than between frames in the blocks. An *idle time* of ten or more high-level bits after a frame indicates the start of a new block (the time of a single bit is calculated directly from the baud value in bits per second). The idle-line multiprocessor communication format is shown in Figure 8–3 (ADDR/IDLE MODE bit is SCICCR.3).

Figure 8–3. Idle-Line Multiprocessor Communication Format

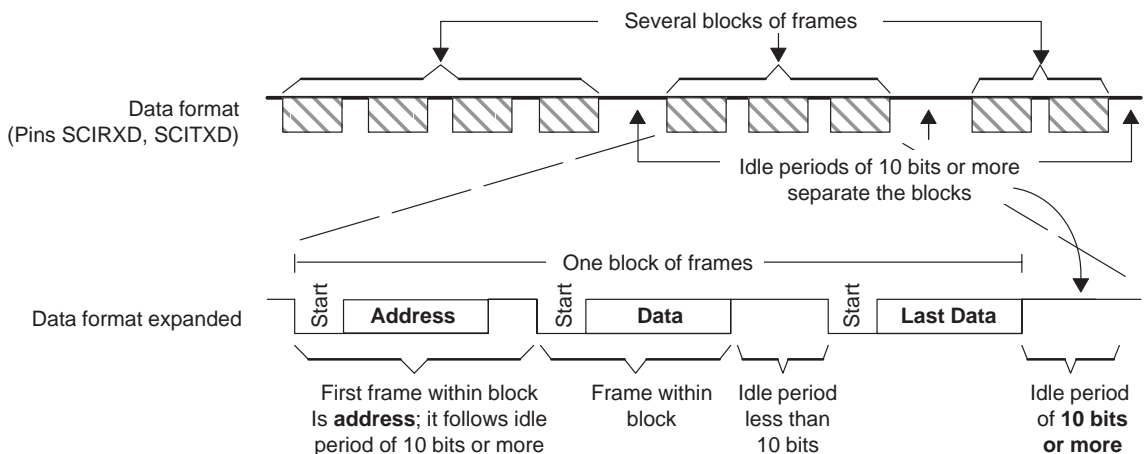

The idle-line mode steps are:

- 1) SCI wakes up after receipt of the block-start signal.
- 2) The processor now recognizes the next SCI interrupt.
- 3) The service routine compares the received address (sent by a remote transmitter) to its own.
- 4) If the CPU is being addressed, the service routine clears the SLEEP bit and receives the rest of the data block.
- 5) If the CPU is not being addressed, the SLEEP bit remains set. This lets the CPU continue to execute its main program without being interrupted by the SCI port until the next detection of a block start.

There are two ways to send a block start signal:

- Method 1:** You intentionally leave an idle time of ten bits or more by delaying the time between the transmission of the last frame of data in the previous block and the transmission of the address frame of the new block.
- Method 2:** The SCI port first sets the TXWAKE bit (SCICTL1.3) to 1 before writing to the SCITXBUF. This sends an idle time of exactly 11 bits. In this method, the serial communications line is not idle any longer than necessary.

Associated with the TXWAKE bit is the wake-up temporary (WUT) flag, which is an internal flag, double-buffered with TXWAKE. When TXSHF is loaded from SCITXBUF, WUT is loaded from TXWAKE, and the TXWAKE bit is cleared to 0. This arrangement is shown below in Figure 8–4 and in Figure 8–1, *SCI block Diagram*, on page 8-4.

Figure 8–4. Double-Buffered WUT and TXSHF

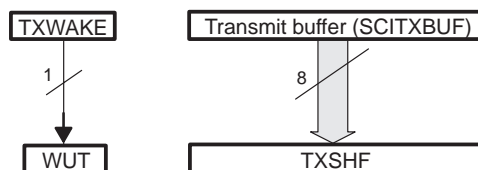

Note: WUT = wake up temporary

To send out a block start signal of exactly one frame time during a sequence of block transmissions, perform the following:

- 1) Write a 1 to the TXWAKE bit.
- 2) Write a data word (the content is not important — any value) to the transmit data buffer (SCITXBUF) to send a block-start signal. The first data word written is suppressed while the block-start signal is sent out and ignored. When the transmit shift register (TXSHF) is free again, SCITXBUF's contents are shifted to TXSHF, the TXWAKE value is shifted to WUT, and TXWAKE is cleared.

Because TXWAKE was set to 1, the start, data, and parity bits are replaced by an idle period of 11 bits transmitted after the last stop bit of the previous frame.

- 3) Write a new address value to SCITXBUF.

A data word of any value must first be written to SCITXBUF before the TXWAKE bit value can be shifted to WUT. After the data word (any value) is shifted to TXSHF, SCITXBUF (and TXWAKE, if necessary), SCITXBUF can be written to again because TXSHF and WUT are both double buffered.

The receiver operates regardless of the SLEEP bit; however, until an address frame is detected, the receiver does not set RXRDY, does not set the status bits, and does not request a receive interrupt.

8.3.2 Address-Bit Multiprocessor Mode[†]

In the address-bit protocol (ADDR/IDLE MODE bit = 1), frames have an extra bit, called an address bit, that immediately follows the last data bit. The address bit is set to 1 in the first frame of the block and to 0 in all other frames. The idle period timing is irrelevant (ADDR/IDLE MODE bit is SCICCR.3). See Figure 8–5, *Address-Bit Multiprocessor Communication Format*, on page 8-13.

The TXWAKE bit value is placed in the address bit. During transmission when the SCITXBUF and TXWAKE are loaded into the TXSHF and WUT, respectively, TXWAKE is reset to 0 and WUT becomes the value of the address bit of the current frame.

[†]Note: For information about TXWAKE control during multiprocessor mode, refer to *Enhancements and Exceptions for the 'F240 DSP Controller* (literature number SPRS066).

To send an address, perform the following steps:

- 1) Set the TXWAKE bit to 1 and write the appropriate address value to SCITXBUF.
- 2) When this address value is transferred to TXSHF and shifted out, its address bit is sent as a 1, which flags the other processors on the serial link to read the address.
- 3) Since TXSHF and WUT are both double buffered, SCITXBUF and TXWAKE can be written to immediately after TXSHF and WUT are loaded.
- 4) To transmit nonaddress frames in the block, leave the TXWAKE bit set to 0.

Note: Address-Bit Format for Transfers of 11 Bytes or Less

As a general rule, the address-bit format is typically used for data frames of 11 bytes or less. This format adds one bit value (1 for an address frame, 0 for a data frame) to all data bytes transmitted. The idle-line format is typically used for data frames of 12 bytes or more.

Figure 8–5. Address-Bit Multiprocessor Communication Format

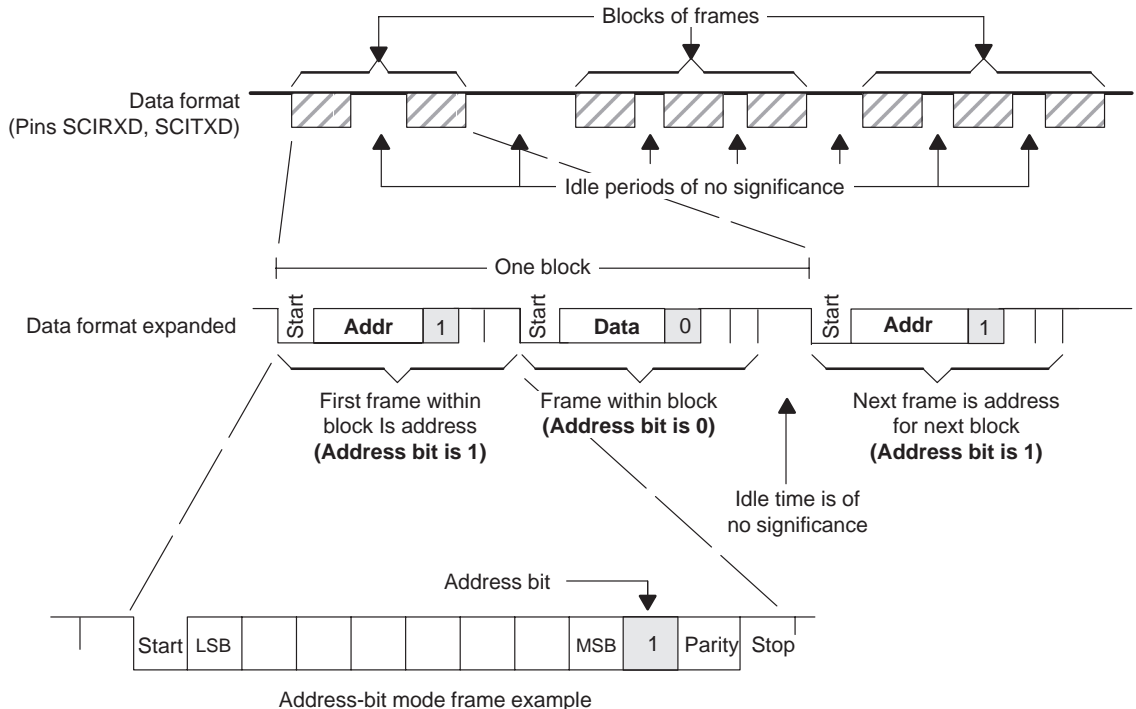

8.4 SCI Communication Format

The SCI asynchronous communication format uses either single-line (one-way) or two-line (two-way) communications. In this mode, the frame consists of a start bit, one to eight data bits, an optional even/odd parity bit, and one or two stop bits (shown in Figure 8–6). There are 8 *SCICLK* periods per data bit.

The receiver begins operation on receipt of a valid start bit. A valid start bit is identified by four consecutive internal *SCICLK* periods of 0 bits, as shown in Figure 8–6. If any bit is not 0, then the processor starts over and begins looking for another start bit.

For the bits following the start bit, the processor determines the bit value by making three samples in the middle of the bits. These samples occur on the fourth, fifth, and sixth *SCICLK* periods, and bit-value determination is on a majority (two out of three) basis. Figure 8–6 illustrates the asynchronous communication format for this with a start bit showing how edges are found and where a majority vote is taken.

Since the receiver synchronizes itself to frames, the external transmitting and receiving devices do not have to use a synchronized serial clock; the clock can be generated locally.

Figure 8–6. SCI Asynchronous Communications Format

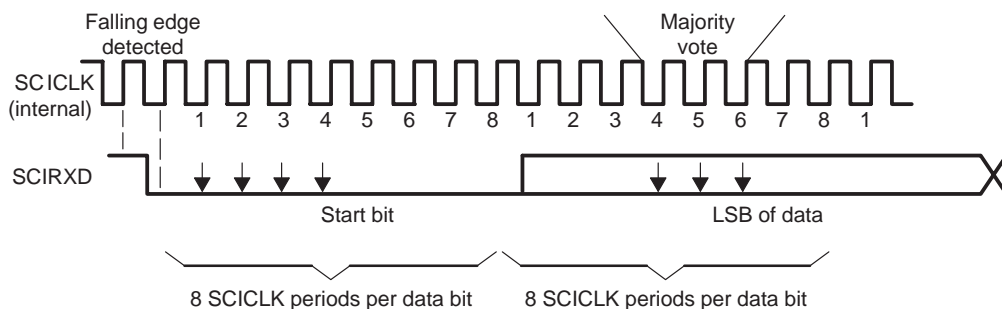

8.4.1 Receiver Signals in Communications Modes

Figure 8–7 illustrates an example of receiver signal timing that assumes the following conditions:

- Address-bit wake-up mode (address bit does not appear in idle-line mode)
- Six bits per character

Figure 8–7. SCI RX Signals in Communication Modes

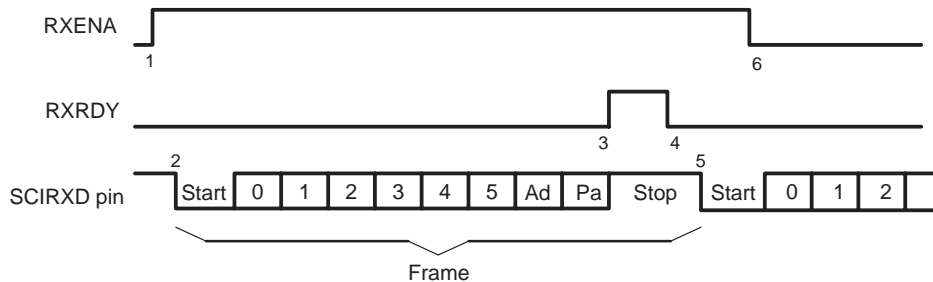

- Notes:**
- 1) Flag bit RXENA (SCICTL1.0) goes high to enable the receiver.
 - 2) Data arrives on the SCIRXD pin, start bit detected.
 - 3) Data is shifted from RXSHF to the receive buffer register (SCIRXBUF); an interrupt is requested. Flag bit RXRDY (SCIRXST.6) goes high to signal that a new character has been received.
 - 4) The program reads SCIRXBUF; flag RXRDY is automatically cleared.
 - 5) The next byte of data arrives on the SCIRXD pin; the start bit is detected, then cleared.
 - 6) Bit RXENA is brought low to disable the receiver. Data continues to be assembled in RXSHF but is not transferred to the receive buffer register.

8.4.2 Transmitter Signals in Communications Modes

Figure 8–8 illustrates an example of transmitter signal timing that assumes the following conditions:

- Address-bit wake-up mode (address bit does not appear in idle-line mode)
- Three bits per character

Figure 8–8. SCI TX Signals in Communications Modes

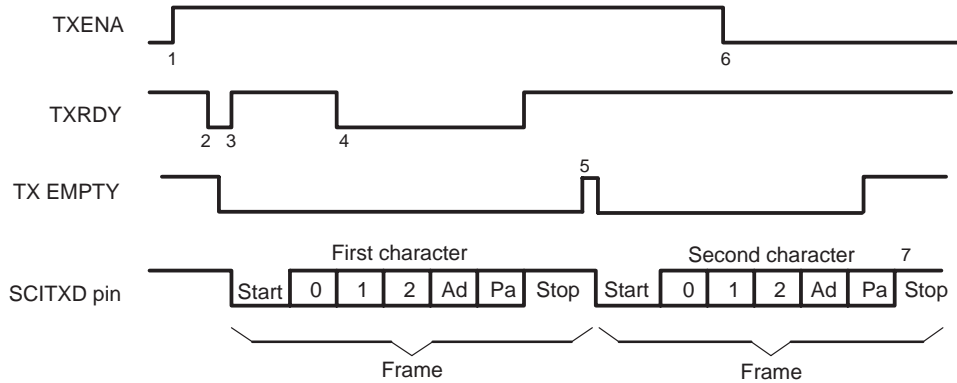

- Notes:**
- 1) Bit TXENA (SCICTL1.1) goes high, enabling the transmitter to send data.
 - 2) SCITXBUF is written to; thus, (1) the transmitter is no longer empty, and (2) TXRDY goes low.
 - 3) The SCI transfers data to the shift register (TXSHF). The transmitter is ready for a second character (TXRDY goes high), and it requests an interrupt (to enable an interrupt, bit TX INT ENA — SCICTL2.0 — must be set).
 - 4) The program writes a second character to SCITXBUF after TXRDY goes high (item 3).
 - 5) Transmission of the first character is complete. TX EMPTY goes high temporarily. Transfer of the second character to shift register TXSHF begins.
 - 6) Bit TXENA goes low to disable the transmitter; the SCI finishes transmitting the current character.
 - 7) Transmission of the second character is complete; transmitter is empty and ready for new character.

8.5 SCI Port Interrupts

The internally-generated serial clock is determined by the SYSCLK frequency and the bank-select registers. The SCI uses the 16-bit value of the baud-select registers to select one of 64K different serial clock rates.

The SCI's receiver and transmitter can be interrupt controlled. The SCICTL2 has one flag bit (TXRDY) that indicates active interrupt conditions and SCIRXST has two interrupt flag bits (RXRDY and BRKDT). The transmitter and receiver have separate interrupt-enable bits. When not enabled, the interrupts are not asserted; however, the condition flags remain active, reflecting transmission and receipt status.

The SCI provides independent interrupt requests and vectors for the receiver and transmitter.

- If the RX/BK INT ENA bit (SCICTL2.1) is set, the receiver interrupt is asserted when one of the following events occurs:
 - The SCI receives a complete frame and transfers the data in RXSHF to SCIRXBUF. This action sets the RXRDY flag (SCIRXST.6) and initiates an interrupt.
 - A break detect condition occurs (the SCIRXD is low for 10-bit periods following a missing stop bit). This action sets the BRKDT flag bit (SCIRXST.5) and initiates an interrupt.
- If the TX INT ENA bit (SCICTL2.0) is set, the transmitter interrupt is asserted whenever the data in SCITXBUF is transferred to TXSHF, indicating that the CPU can write to TXBUF. This action sets the TXRDY flag bit (SCICTL2.7) and initiates an interrupt.

SCI interrupts can be programmed into different priority levels by the SCIRX PRIORITY (SCIPRI.5) and SCITX PRIORITY (SCIPRI.6) control bits. When both RX and TX interrupt requests are made on the same level, the receiver always has higher priority than the transmitter, reducing the possibility of receiver overrun.

8.5.1 SCI Baud Rate Calculation

The internally-generated serial clock is determined by the SYSCLK frequency and the baud-select registers. The SCI uses the 16-bit value of the baud-select registers to select one of the 64K different serial clock rates.

The SCI baud rate for the different communication modes is determined in the following ways:

- SCI asynchronous baud for BRR = 1 to 65 535

$$SCI\ asynchronous\ baud = \frac{SYSCLK}{(BRR + 1) \times 8}$$

$$BRR = \frac{SYSCLK}{SCI\ asynchronous\ baud \times 8} - 1$$

- SCI asynchronous baud for BRR = 0

$$SCI\ asynchronous\ baud = \frac{SYSCLK}{16}$$

Where BRR : = the 16-bit value in the baud-select registers

Table 8–3 defines the *actual* baud rates for different *ideal* baud rates. The baud-select registers are further defined in section 8.6.3, *Baud-Select Registers (SCIHBAUD and SCILBAUD)*, on page 8-25.

Table 8–3. Asynchronous Baud Register Values for Common SCI Bit Rates

Ideal Baud Selected	SYSCLK Frequency											
	1 MHz			5 MHz			8 MHz			10 MHz		
	BRR	Actual Baud Selected	% Error	BRR	Actual Baud Selected	% Error	BRR	Actual Baud Selected	% Error	BRR	Actual Baud Selected	% Error
300	416	300	-0.08	2082	300	0.02	3332	300	0.01	4166	300	-0.01
600	207	601	0.16	1041	600	-0.03	1666	600	-0.02	2082	600	0.02
1200	103	1202	0.16	520	1200	-0.03	832	1200	0.04	1041	1200	-0.03
2400	51	2404	0.16	259	2404	0.16	416	2398	-0.08	520	2399	-0.03
4800	25	4808	0.16	129	4808	0.16	207	4808	0.16	259	4808	0.16
8192	14	8333	1.73	75	8224	0.39	121	8197	0.06	152	8170	-0.27
9600	12	9615	0.16	64	9615	0.16	103	9615	0.16	130	9542	-0.60
19200	6	17857	-6.99	32	18939	-1.36	51	19231	0.16	64	19231	0.16

8.6 SCI Control Registers

SCI functions are software configurable. Sets of control bits, organized into dedicated bytes, are programmed to initialize the desired SCI communications format. This includes: operating mode and protocol, baud value, character length, even/odd parity or no parity, number of stop bits, and interrupt priorities and enables. The SCI is controlled and accessed through registers listed in Figure 8–9 and described in the sections that follow.

Figure 8–9. SCI Control Registers

Address	Register	Bit number							
		7	6	5	4	3	2	1	0
7050h	SCICCR	STOP BITS	EVEN/ODD PARITY	PARITY ENABLE	SCI ENA	ADDR/IDLE MODE	SCI CHAR2	SCI CHAR1	SCI CHAR0
7051h	SCICTL1	Reserved	RX ERR INT ENA	SW RESET	CLOCK ENA	TXWAKE	SLEEP	TXENA	RXENA
7052h	SCIHBAUD	BAUD15 (MSB)	BAUD14	BAUD13	BAUD12	BAUD11	BAUD10	BAUD9	BAUD8
7053h	SCILBAUD	BAUD7	BAUD6	BAUD5	BAUD4	BAUD3	BAUD2	BAUD1	BAUD0 (LSB)
7054h	SCICTL2	TXRDY	TX EMPTY	Reserved				RX/BK INT ENA	TX INT ENA
7055h	SCIRXST	RX ERROR	RXRDY	BRKDT	FE	OE	PE	RXWAKE	Reserved
7056h	SCIRXEMU	ERXDT7	ERXDT6	ERXDT5	ERXDT4	ERXDT3	ERXDT2	ERXDT1	ERXDT0
7057h	SCIRXBUF	RXDT7	RXDT6	RXDT5	RXDT4	RXDT3	RXDT2	RXDT1	RXDT0
7058h	—	Reserved							
7059h	SCITXBUF	TXDT7	TXDT6	TXDT5	TXDT4	TXDT3	TXDT2	TXDT1	TXDT0
705Ah	—	Reserved							
705Bh	—	Reserved							
705Ch	—	Reserved							
705Dh	—	Reserved							
705Eh	SCIPC2	SCITXD DATA IN	SCITXD DATA OUT	SCITXD FUNCTION	SCITXD DATA DIR	SCIRXD DATA IN	SCIRXD DATA OUT	SCIRXD FUNCTION	SCIRXD DATA DIR
705Fh	SCIPRI	Reserved	SCITX PRIORITY	SCIRX PRIORITY	SCI ESPEN	Reserved			

8.6.1 SCI Communication Control Register (SCICCR)

The SCICCR defines the character format, protocol, and communications mode used by the SCI.

Figure 8–10. SCI Communication Control Register (SCICCR) — Address 7050h

7	6	5	4	3	2	1	0
STOP BITS	EVEN/ODD PARITY	PARITY ENABLE	SCI ENA	ADDR/IDLE MODE	SCI CHAR2	SCI CHAR1	SCI CHAR0
RW–0	RW–0	RW–0	RW–0	RW–0	RW–0	RW–0	RW–0

Note: R = read access, W = write access, –0 = value after reset

- Bit 7** **STOP BITS.** SCI number of stop bits. This bit specifies the number of stop bits transmitted. The receiver checks for only one stop bit.

 - 0 = One stop bit
 - 1 = Two stop bits
- Bit 6** **PARITY.** SCI parity odd/even selection. If the PARITY ENABLE bit (SCICCR.5) is set, PARITY (bit 6) designates odd or even parity (odd or even number of bits with the value of 1 in both transmitted and received characters).

 - 0 = Odd parity
 - 1 = Even parity
- Bit 5** **PARITY ENABLE.** SCI parity enable. This bit enables or disables the parity function. If the SCI is in the address-bit multiprocessor mode (set using bit 3 of this register), the address bit is included in the parity calculation if parity is enabled. For characters of less than eight bits, the remaining unused bits must be masked out of the parity calculation.

 - 0 = Parity disabled; no parity bit is generated during transmission or is expected during reception.
 - 1 = Parity is enabled.
- Bit 4** **SCI ENA.** SCI communication enable bit. This bit must be set to 1 for operation.

Bit 3 ADDR/IDLE MODE. SCI multiprocessor mode control bit. This bit selects one of the multiprocessor protocols:

- 0 = Idle-line mode protocol is selected
- 1 = Address-bit mode protocol is selected

Multiprocessor communication is different from the other communication modes because it uses SLEEP and TXWAKE functions (bits SCICTL1.2 and SCICTL1.3, respectively). (Both of these bits are further described in Section 8.3, *SCI Multiprocessor Communication*, on page 8-9). The idle-line mode is usually used for normal communications because the address-bit mode adds an extra bit to the frame. The idle-line mode does not add this extra bit and, therefore, is compatible with RS-232-type communications.

Bits 2–0 SCI CHAR2–0. Character-length control bits. These bits set the SCI character length from one to eight bits. Characters of less than eight bits are right-justified in SCIRXBUF and SCIRXEMU and are filled with leading 0s in SCIRXBUF. SCITXBUF is not filled with leading 0s. Table 8–4 lists the bit values and character lengths for SCI CHAR2–0 bits.

Table 8–4. SCI CHAR2 — 0 Bit Values and Character Lengths

SCI CHAR2–0 Bit Values			
SCI CHAR2	SCI CHAR1	SCI CHAR0	Character Length (Bits)
0	0	0	1
0	0	1	2
0	1	0	3
0	1	1	4
1	0	0	5
1	0	1	6
1	1	0	7
1	1	1	8

8.6.2 SCI Control Register 1 (SCICTL1)

The SCICTL1 controls the receiver/transmitter enable, TXWAKE and SLEEP functions, internal clock enable, and the SCI software reset.

Figure 8–11. SCI Control Register 1 (SCICTL1) — Address 7051h

7	6	5	4	3	2	1	0
Reserved	RX ERR INT ENA	SW RESET	CLOCK ENA	TXWAKE	SLEEP	TXENA	RXENA
	RW-0	RW-0	RW-0	RS-0	RW-0	RW-0	RW-0

Note: R = read access, W = write access, S = set only, -0 = value after reset

- Bit 7** **Reserved.** Reads are indeterminate, and writes have no effect
- Bit 6** **RX ERR INT ENA.** SCI receiver enable. Setting this bit enables an interrupt if the RX ERROR bit (SCIRXST.7) becomes set because of errors. This interrupt capability is provided for error detection when the SCI is serviced by the DMAC.
 - 0 = Receive error interrupt is disabled
 - 1 = Receive error interrupt is enabled

- Bit 5** **SW RESET.** SCI software reset (active low). Writing a 0 to this bit initializes the SCI state machines and operating flags (SCICTL2 and SCIRXST) to the reset condition.

The SW RESET bit does not affect any of the configuration bits and does not change the state of the CLOCK ENA bit, bit4.

All affected logic is held in the specified reset state until a 1 is written to SW RESET (the bit values following a reset are shown beneath each register diagram in this section). Thus, after a system reset, reenable the SCI by writing a 1 to this bit.

Clear this bit after a receiver break detect (BRKDT flag, bit SCIRXST.5).

SW RESET affects the operating flags of the SCI, but it neither affects the configuration bits nor restores the reset values. Table 8–5, *SW Reset-Affected Flags*, on page 8-23 lists the affected flags.

Once SW RESET is asserted, the flags are frozen until the bit is deasserted.

Note: Do Not Change Configuration when SW RESET bit = 1

The SCI configuration must not be set or altered unless the SW RESET bit is cleared. Set up all configuration registers before setting SW RESET; otherwise, behavior may be unpredictable.

Table 8–5. SW RESET-Affected Flags

SCI Flag	Register.Bit	Value After SW RESET
TXRDY	SCICTL2.7	1
TX EMPTY	SCICTL2.6	1
RXWAKE	SCIRXST.1	0
PE	SCIRXST.2	0
OE	SCIRXST.3	0
FE	SCIRXST.4	0
BRKDT	SCIRXST.5	0
RXRDY	SCIRXST.6	0
RX ERROR	SCIRXST.7	0

Bit 4 **CLOCK ENA.** SCI internal clock enable. This bit determines the source of the module clock on the SCICLK pin (see Figure 8–1, *SCI Block Diagram*, on page 8-4 :

- 0 = Disable internal clock
- 1 = Enable internal clock

Bit 3 **TXWAKE.** SCI transmitter wakeup method select. The TXWAKE bit controls selection of the data-transmit feature, depending on which transmit mode (idle line or address bit) is specified at the ADDR/IDLE MODE bit (SCICCR.3):

- 0 = Transmit feature is not selected
- 1 = Transmit feature selected is dependent on the mode: idle-line or address-bit:

Idle-line mode: write a 1 to TXWAKE, then write data to register SCITXBUF to generate an idle period of 11 data bits

Address-bit mode: write a 1 to TXWAKE, then write data to SCITXBUF to set the address bit for that frame to 1

TXWAKE is not cleared by the SW RESET bit (SCICTL1.5). This bit is only cleared by a system reset or by the transfer of TXWAKE to the WUT flag (see Figure 8–4, *Double-buffered WUT and TXSHF* on page 8-11).

Bit 2 **SLEEP.** SCI sleep. In a multiprocessor configuration, this bit controls the receive sleep function. Clearing this bit brings the SCI out of the sleep mode. This configuration and process are further explained in section 8.3, *SCI Multi-processor Communication*, on page 8-9.

- 0 = Sleep mode is disabled
- 1 = Sleep mode is enabled

The receiver still operates when the SLEEP bit is set; however, operation does not update the receive buffer ready bit (SCIRXST.6, RXRDY) or the error status bits (SCIRXST.5–2: BRKDT, FE, OE, and PE) unless the address byte is detected. This bit is not cleared when the address byte is detected.

Bit 1 **TXENA.** SCI transmitter enable. Data is transmitted through the SCITXD pin only when TXENA is set (see Figure 8–1, *SCI Block Diagram*, on page 8-4). If reset, transmission is halted but only after all data previously written to SCITX-BUF has been sent.

- 0 = Transmitter is disabled
- 1 = Transmitter is enabled

Bit 0 **RXENA.** SCI receiver enable. Data is received on the SCIRXD pin (see Figure 8–1 on page 8-4) and is sent to the receive shift register and then the receive buffers. This bit enables or disables the receiver (transfers to the buffers).

- 0 = Prevent received characters from transfer into SCIRXEMU and SCIRXBUF receive buffers
- 1 = Send receive characters into SCIRXEMU and SCIRXBUF

Clearing RXENA stops received characters from being transferred into the two receive buffers and also stops the generation of receiver interrupts. However, the receiver shift register can continue to assemble characters. Thus, if RXENA is set during the reception of a character, the complete character is transferred into the receive buffer registers, SCIRXEMU and SCIRXBUF.

8.6.3 Baud-Select Registers (SCIHBAUD and SCILBAUD)

The values in the SCI baud-select registers (SCIHBAUD and SCILBAUD) specify the baud rate for the SCI.

Figure 8–12. SCI Baud-Select MSbyte Register (SCIHBAUD) — Address 7052h

15	14	13	12	11	10	9	8
BAUD15 (MSB)	BAUD14	BAUD13	BAUD12	BAUD11	BAUD10	BAUD9	BAUD8
RW–0	RW–0	RW–0	RW–0	RW–0	RW–0	RW–0	RW–0

Note: R = read access, W = write access, –0 = value after reset

Figure 8–13. SCI Baud-Select LSbyte Register (SCILBAUD) — Address 7053h

7	6	5	4	3	2	1	0
BAUD7	BAUD6	BAUD5	BAUD4	BAUD3	BAUD2	BAUD1	BAUD0 (LSB)
RW–0	RW–0	RW–0	RW–0	RW–0	RW–0	RW–0	RW–0

Note: R = read access, W = write access, –0 = value after reset

Bits 15–0 BAUD15–BAUD0. SCI 16-bit baud selection. SCIHBAUD (MSbyte) and SCILBAUD (LSbyte) concatenate to form a 16-bit baud value.

The internally-generated serial clock is determined by the SYSCLK and the two baud select registers. The SCI uses the 16-bit value of these registers to select one of 64K serial clock rates for the communication modes.

The SCI baud rate for the different communication modes is determined in the following ways:

- For BRR = 1 to 65 535

$$SCI \text{ asynchronous baud} = \frac{SYSCLK}{(BRR + 1) \times 8}$$

$$BRR = \frac{SYSCLK}{SCI \text{ asynchronous baud} \times 8} - 1$$

- For BRR = 0

$$SCI \text{ asynchronous baud} = \frac{SYSCLK}{16}$$

Where BRR : = 16-bit value in the baud-select registers

8.6.4 SCI Control Register 2 (SCICTL2)

SCICTL2 enables the receive-ready, break-detect, and transmit-ready interrupts as well as transmitter-ready and -empty flags.

Figure 8–14. SCI Control Register 2 (SCICTL2) — Address 7054h

7	6	5 – 2	1	0
TXRDY	TX EMPTY	Reserved	RX/BK INT ENA	TX INT ENA
R–1	R–1		RW–0	RW–0

Note: R = read access, W = write access, –n = value after reset

Bit 7 **TXRDY.** Transmitter buffer-register ready flag. When set, this bit indicates that the transmit buffer register, SCITXBUF, is ready to receive another character. Writing data to SCITXBUF automatically clears this bit. When set, this flag asserts a transmitter interrupt request if the interrupt-enable bit TX INT ENA (SCICTL2.0) is also set. TXRDY is set to 1 by enabling the SW RESET bit (SCICTL.2) or by a system reset.

- 0 = SCITXBUF is full
- 1 = SCITXBUF is ready to receive the next character

Bit 6 **TX EMPTY.** Transmitter empty flag. This flag’s value indicates the contents of the transmitter’s buffer register (SCITXBUF) and shift register (TXSHF). An active SW RESET (SCICTL1.2) or a system reset sets this bit. This bit does not cause an interrupt request.

- 0 = Transmitter buffer or shift register or both are loaded with data
- 1 = Transmitter buffer and shift registers are both empty

Bits 5–2 **Reserved.** Reads are indeterminate, and writes have no effect.

Bit 1 **RX/BK INT ENA.** Receiver-buffer/break interrupt enable. This bit controls the interrupt request caused by either the RXRDY flag or the BRKDT flag (bits SCIRXST.6 and .5) being set. However, RX/BRK INT ENA does not prevent the setting of these flags.

- 0 = Disable RXRDY/BRKDT interrupt
- 1 = Enable RXRDY/BRKDT interrupt

Bit 0 **TX INT ENA.** SCITXBUF-interrupt enable. This bit controls the issue of an interrupt request caused by setting the TXRDY flag bit (SCICTL2.7). However, it does not prevent the TXRDY flag from being set (being set indicates that SCITXBUF is ready to receive another character).

- 0 = Disable TXRDY interrupt
- 1 = Enable TXRDY interrupt

8.6.5 Receiver Status Register (SCIRXST)

SCIRXST, shown in Figure 8–15, contains seven bits that are receiver status flags (two of which can generate interrupt requests). Each time a complete character is transferred to the receive buffers (SCIRXEMU and SCIRXBUF), the status flags are updated. Each time the buffers are read, the flags are cleared. Figure 8–16, *SCIRXST Bit Associations*, on page 8-29 shows the relationships between several of the register's bits.

Figure 8–15. SCI Receiver Status Register (SCIRXST) — Address 7055h

7	6	5	4	3	2	1	0
RX ERROR	RXRDY	BRKDT	FE	OE	PE	RXWAKE	Reserved
R–0	R–0	R–0	R–0	R–0	R–0	R–0	

Note: R = read access, –0 = value after reset

Bit 7 **RX ERROR.** SCI receiver-error flag. The RX ERROR flag indicates that one of the error flags in the receiver status register is set. RX ERROR is a logical OR of the break detect, framing error, overrun, and parity enable flags (bits 5–2: BRKDT, FE, OE, and PE).

- 0 = No error flags are set
- 1 = Error flag(s) is set

A 1 on this bit causes an interrupt if the RX ERR INT ENA bit (SCICTL1.6) is set. This bit can be used for fast error-condition checking during the interrupt service routine. This error flag cannot be cleared directly; it is cleared by an active SW RESET or by a system reset.

Bit 6 **RXRDY.** SCI receiver-ready flag. When a new character is ready to be read into SCIRXBUF, the receiver sets this bit and a receiver interrupt is generated if the RX/BK INT ENA bit (SCICTL2.1) is a 1. RXRDY is cleared by reading SCIRXBUF, by an active SW RESET, or by a system reset.

- 0 = No new character in SCIRXBUF.
- 1 = Character ready to be read from SCIRXBUF

- Bit 5** **BRKDT.** SCI break-detect flag. The SCI sets this bit when a break condition occurs. A break condition occurs when the SCI receive data line (see SCIRXD on the right side of Figure 8–1, *SCI Block Diagram*, on page 8-4) remains continuously low for at least ten bits after a missing first stop bit. The occurrence of a break causes a receiver interrupt to be generated if the RX/BK INT ENA bit is a 1, but it does not cause the receiver buffer to be loaded. A BRKDT interrupt can occur, even if the receiver SLEEP bit is set to 1.
- BRKDT is cleared by an active SW RESET or by a system reset. It is not cleared by receipt of a character after the break is detected. In order to receive more characters, the SCI must be reset by toggling the SW RESET bit or by a system reset.
- 0 = No break condition
1 = Break condition occurred
- Bit 4** **FE.** SCI framing-error flag. The SCI sets this bit when an expected stop bit is not found. Only the first stop bit is checked. The missing stop bit indicates that synchronization with the start bit has been lost and that the character is incorrectly framed. It is reset by clearing the SW RESET bit or by a system reset.
- 0 = No framing error is detected
1 = Framing error is detected
- Bit 3** **OE.** SCI overrun-error flag. The SCI sets this bit when a character is transferred into SCIRXEMU and SCIRXBUF before the previous character is fully read by the CPU — a condition in which the previous character is overwritten and lost. The OE flag is reset by an active SW RESET or by a system reset.
- 0 = No overrun error is detected
1 = Overrun error is detected
- Bit 2** **PE.** SCI parity-error flag. This flag bit is set when a character is received with a mismatch between the number of 1s and its parity bit. The address bit is included in the calculation. If parity generation and detection is not enabled, the PE flag is disabled and read as 0. The PE bit is reset by an active SW RESET or a system reset.
- 0 = No parity error or parity is disabled
1 = Parity error is detected

Bit 1 **RXWAKE.** Receiver wakeup-detect flag. A value of 1 in this bit indicates detection of a receiver wakeup condition. In the address bit multiprocessor mode (SCICCR.3 = 1), RXWAKE reflects the value of the address bit for the character contained in SCIRXBUF. In the idle-line multiprocessor mode, RXWAKE is set if the SCIRXD data line is detected as idle (this line is the input to RXSHF as shown in Figure 8–1, *SCI Block Diagram*, on page 8-4). RXWAKE is a read-only flag, cleared by one of the following:

- The transfer of the first byte after the address byte to SCIRXBUF
- The reading of SCIRXBUF
- An active SW RESET
- A system reset

See section 8.3, *SCI Multiprocessor Communication*, on page 8-9 for details on the SCI multiprocessor address-bit and idle-line communication modes.

Bit 0 **Reserved.** Reads are indeterminate, and writes have no effect.

Figure 8–16. *SCIRXST Bit Associations*

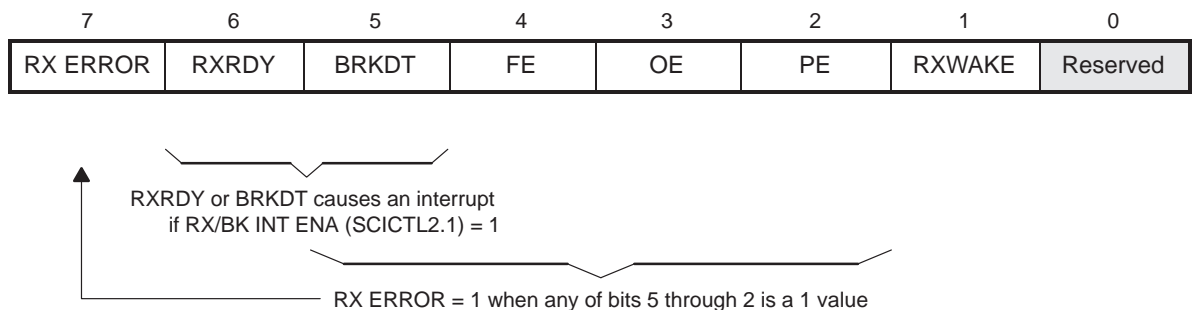

8.6.6 Receiver Data Buffer Registers

Received data is transferred from RXSHF to SCIRXEMU and then to SCIRXBUF. When the transfer is complete, the RXRDY flag (bit SCIRXST.6) is set, indicating that the received data is ready to be read. Both registers contain the same data; they have separate addresses but are not physically separate buffers. The only difference is that reading SCIRXEMU does not clear the RXRDY flag; however, reading SCIRXBUF does clear the flag.

Emulation data buffer (SCIRXEMU)

For normal SCI data receipt operations, the data received from SCIRXBUF. SCIRXEMU is used principally by the emulator (EMU) because it can continually read the data received for screen updates without clearing the RXRDY flag. SCIRXEMU is cleared by system reset.

Figure 8–17. SCI Emulation Data Buffer Register (SCIRXEMU) — Address 7056h

7	6	5	4	3	2	1	0
ERXDT7	ERXDT6	ERXDT5	ERXDT4	ERXDT3	ERXDT2	ERXDT1	ERXDT0
R-x	R-x	R-x	R-x	R-x	R-x	R-x	R-x

Note: R = read access, -n = value after reset (x = indeterminate)

Receiver data buffer (SCIRXBUF)

When the current data received is shifted from RXSHF to the receive buffer, flag bit RXRDY is set and the data is ready to be read. If the RX/BK INT ENA bit (SCICTL2.1) is set, this shift also causes an interrupt. When SCIRXBUF is read, the RXRDY flag is reset. SCIRXBUF is cleared by a system reset.

Figure 8–18. SCI Receiver Data Buffer Register (SCIRXBUF) — Address 7057h

7	6	5	4	3	2	1	0
RXDT7	RXDT6	RXDT5	RXDT4	RXDT3	RXDT2	RXDT1	RXDT0
R-x	R-x	R-x	R-x	R-x	R-x	R-x	R-x

Note: R = Read access, -n = value after reset (x = indeterminate)

8.6.7 Transmit data buffer register (SCITXBUF)

Data bits to be transmitted are written to the transmit data buffer register (SCITXBUF). The transfer of data from this register to the TXSHF transmitter shift register sets the TXRDY flag (SCICTL2.7), indicating that SCITXBUF is ready to receive another set of data. If bit TX INT ENA (SCICTL2.0) is set, this data transfer also causes an interrupt. These bits must be right justified because the leftmost bits are ignored for characters less than eight bits long.

Figure 8–19. SCI Transmit Data Buffer Register (SCITXBUF) — Address 7059h

7	6	5	4	3	2	1	0
TXDT7	TXDT6	TXDT5	TXDT4	TXDT3	TXDT2	TXDT1	TXDT0
RW-0	RW-0	RW-0	RW-0	RW-0	RW-0	RW-0	RW-0

Note: R = read access, W = write access, -0 = value after reset

8.6.8 Port Control Register 2 (SCIPC2)

SCIPC2 controls the functions of pins SCITXD and SCIRXD.

Figure 8–20. SCI Port Control Register 2 (SCIPC2) — Address 705Eh

7	6	5	4	3	2	1	0
SCITXD DATA IN	SCITXD DATA OUT	SCITXD FUNCTION	SCITXD DATA DIR	SCIRXD DATA IN	SCIRXD DATA OUT	SCIRXD FUNCTION	SCIRXD DATA DIR
R-x	RW-0	RW-0	RW-0	R-x	RW-0	RW-0	RW-0

Note: R = read access, W = write access, -n = value after reset (x = indeterminate)

- Bit 7** **SCITXD DATA IN.** Contains the current value of pin SCITXD.
- 0 = Pin SCITXD value read as 0
 - 1 = Pin SCITXD value read as 1
- Bit 6** **SCITXD DATA OUT.** Value to be output on pin SCITXD. This bit contains the data to be output on the SCITXD if it is a general-purpose digital I/O output pin. For this configuration, clear bit SCIPC2.5 to 0 and set bit SCIPC2.4 to 1.
- Bit 5** **SCITXD FUNCTION.** Defines the function of pin SCITXD.
- 0 = SCITXD is a general-purpose digital I/O pin
 - 1 = SCITXD is a the SCI transmit pin
- Bit 4** **SCITXD DATA DIR.** Defines the data direction of pin SCITXD. If SCITXD is configured as a general-purpose I/O pin (bit 5 = 0), this bit specifies SCITXD's direction:
- 0 = SCITXD is a digital input pin
 - 1 = SCITXD is a digital output pin
- Bit 3** **SCIRXD DATA IN.** Contains current value of pin SCIRXD.
- 0 = SCIRXD value read as 0
 - 1 = SCIRXD value read as 1
- Bit 2** **SCIRXD DATA OUT.** Value to be output on pin SCIRXD. This bit contains the data to be output on pin SCIRXD if SCIRXD is a general-purpose digital output pin. For this configuration, you *must* clear bit SCIPC2.1 to 0 (pin is general-purpose) and set bit SCIPC2.0 to 1 (pin is digital output).
- 0 = A 0 value output on pin SCIRXD
 - 1 = A 1 value output on pin SCIRXD

Bit 1 **SCIRXD FUNCTION.** Defines the function of pin SCIRXD.

- 0 = SCIRXD is a general-purpose digital I/O pin
- 1 = SCIRXD is the SCI receive pin

Bit 0 **SCIRXD DATA DIR.** Defines the data direction of pin SCIRXD. If SCIRXD is configured as a general-purpose I/O pin (bit SCIPC2.1 = 0), this bit specifies pin SCIRXD's direction:

- 0 = SCIRXD is a digital input pin
- 1 = SCIRXD is a digital output pin

8.6.9 Priority Control Register (SCIPRI)

SCIPRI contains the receiver and transmitter interrupt priority select bits.

Figure 8–21. SCI Priority Control Register (SCIPRI) — Address 705Fh

7	6	5	4	3–0
Reserved	SCITX PRIORITY	SCIRX PRIORITY	SCI ESPEN	Reserved
	RW–0	RW–0	RW–0	

Note: R = read access, W = write access, –0 = value after reset

- Bit 7** **Reserved.** Reads are indeterminate; writes have no effect.
- Bit 6** **SCITX PRIORITY.** SCI transmitter interrupt priority select. This bit specifies priority level of the SCI transmitter interrupts.
- 0 = Interrupts are high-priority requests
 - 1 = Interrupts are low-priority requests
- Bit 5** **SCIRX PRIORITY.** SCI receiver interrupt priority select. This bit specifies the priority level to the SCI receiver interrupts.
- 0 = Interrupts are high-priority requests
 - 1 = Interrupts are low-priority requests
- Bit 4** **SCI ESPEN.** SCI emulator suspend enable. This bit has an effect only when debugging a program with the XDS emulator. This bit determines how the SCI operates when the program is suspended.
- 0 = When the suspended signal goes high, the SCI continues operation until the current transmit and receive functions are complete
 - 1 = When the suspend signal goes high, the SCI state machine is frozen
- Bits 3 – 0** **Reserved.** Reads are indeterminate, and writes have no effect.

8.7 SCI Initialization Example

Example 8–1. Asynchronous Communication Routine

```

;*****
; File Name:   TMS320x240 SCI Idle-line Mode Example Code
;
; Description: This program uses the SCI module to implement a simple
;              asynchronous communications routine. The SCI is
;              initialized to operate in idle-line mode with 8 character
;              bits, 1 stop bit, and odd parity. The SCI Baud Rate
;              Registers (BRR) are set to transmit and receive data at
;              19200 baud. The SCI generates an interrupt every time a
;              character is loaded into the receive buffer (SCIRXBUF).
;              The interrupt service routine(ISR) reads the receive
;              buffer and determines if the carriage return button, <CR>,
;              has been pressed. If so, the character string "Ready" is
;              transmitted. If not, no character string is transmitted.
;*****
; SET statements for '24x devices are device dependent. The SET
; locations used in this example are typically true for devices with
; only one SCI module. Consult the device data sheet to determine the
; exact memory map locations of the modules you will be accessing
; (control registers, RAM, ROM).
;
;               .include "c240reg.h"           ; contains a list of SET statements
;                                               ; for all registers on TMS320x240.
; The following SET statements for the SCI are contained in c240reg.h
; and are shown explicitly for clarity.
;Serial Communications Interface (SCI) Registers
;-----
SCICCR      .set    07050h      ;SCI Comms Control Reg
SCICTL1     .set    07051h      ;SCI Control Reg 1
SCIHBAUD    .set    07052h      ;SCI Baud rate control
SCILBAUD    .set    07053h      ;SCI Baud rate control
SCICTL2     .set    07054h      ;SCI Control Reg 2
SCIRXST     .set    07055h      ;SCI Receive status reg
SCIRXEMU    .set    07056h      ;SCI EMU data buffer
SCIRXBUF    .set    07057h      ;SCI Receive data buffer
SCITXBUF    .set    07059h      ;SCI Transmit data buffer
SCIPC2      .set    0705Eh      ;SCI Port control reg2
SCIPRI      .set    0705Fh      ;SCI Priority control reg
;-----
; Constant definitions
;-----
LENGTH      .set    00005h      ; length of the data stream to be
;                               ; transmitted
;-----
; Variable definitions
;-----
          .bss     DATA_OUT,LENGTH ; Location of LENGTH byte character
;                               ; stream to be transmitted
          .bss     GPR0,1         ;General purpose register.

```

Example 8–1. Asynchronous Communication Routine (Continued)

```

;-----
; Macro definitions
;-----
KICK_DOG      .macro                ;Watchdog reset macro
               LDP      #00E0h
               SPLK    #055h, WDKEY
               SPLK    #0AAh, WDKEY
               LDP      #0h
               .endm
;-----
;Bit codes for Test bit instruction (BIT)
;-----
BIT15         .set    0000h          ;Bit Code for 15
BIT14         .set    0001h          ;Bit Code for 14
BIT13         .set    0002h          ;Bit Code for 13
BIT12         .set    0003h          ;Bit Code for 12
BIT11         .set    0004h          ;Bit Code for 11
BIT10         .set    0005h          ;Bit Code for 10
BIT9          .set    0006h          ;Bit Code for 9
BIT8          .set    0007h          ;Bit Code for 8
BIT7          .set    0008h          ;Bit Code for 7
BIT6          .set    0009h          ;Bit Code for 6
BIT5          .set    000Ah          ;Bit Code for 5
BIT4          .set    000Bh          ;Bit Code for 4
BIT3          .set    000Ch          ;Bit Code for 3
BIT2          .set    000Dh          ;Bit Code for 2
BIT1          .set    000Eh          ;Bit Code for 1
BIT0          .set    000Fh          ;Bit Code for 0
;-----
; Initialized Transmit Data for Interrupt Service Routine
;-----
               .data
TXDATA        .word 0052h            ;Hex equivalent of ASCII character 'R'
               .word 0065h            ;Hex equivalent of ASCII character 'e'
               .word 0061h            ;Hex equivalent of ASCII character 'a'
               .word 0064h            ;Hex equivalent of ASCII character 'd'
               .word 0079h            ;Hex equivalent of ASCII character 'y'
;-----
; Vector address declarations
;-----
               .sect  "vectors"
RSVECT        B      START           ; PM 0      Reset Vector      1
INT1          B      INT1_ISR        ; PM 2      Int level 1      4
INT2          B      PHANTOM         ; PM 4      Int level 2      5
INT3          B      PHANTOM         ; PM 6      Int level 3      6
INT4          B      PHANTOM         ; PM 8      Int level 4      7
INT5          B      PHANTOM         ; PM A      Int level 5      8
INT6          B      PHANTOM         ; PM C      Int level 6      9
RESERVED      B      PHANTOM         ; PM E      (Analysis Int) 10
SW_INT8       B      PHANTOM         ; PM 10     User S/W int    -
SW_INT9       B      PHANTOM         ; PM 12     User S/W int    -

```

Example 8–1. Asynchronous Communication Routine (Continued)

```

SW_INT10    B    PHANTOM    ; PM 14    User S/W int    -
SW_INT11    B    PHANTOM    ; PM 16    User S/W int    -
SW_INT12    B    PHANTOM    ; PM 18    User S/W int    -
SW_INT13    B    PHANTOM    ; PM 1A    User S/W int    -
SW_INT14    B    PHANTOM    ; PM 1C    User S/W int    -
SW_INT15    B    PHANTOM    ; PM 1E    User S/W int    -
SW_INT16    B    PHANTOM    ; PM 20    User S/W int    -
TRAP        B    PHANTOM    ; PM 22    Trap vector     -
NMI         B    PHANTOM    ; PM 24    Non maskable Int3
EMU_TRAP    PHANTOM    ; PM 26    Emulator Trap  2
SW_INT20    B    PHANTOM    ; PM 28    User S/W int    -
SW_INT21    B    PHANTOM    ; PM 2A    User S/W int    -
SW_INT22    B    PHANTOM    ; PM 2C    User S/W int    -
SW_INT23    B    PHANTOM    ; PM 2E    User S/W int    -
;=====
; M A I N   C O D E   - starts here
;=====
        .text
START:   SETC    INTM        ;Disable interrupts
        CLRC    SXM        ;Clear Sign Extension Mode
        CLRC    OVM        ;Reset Overflow Mode
        CLRC    CNF        ;Config Block B0 to Data mem.
        LDP     #00E0h
        SPLK   #006Fh, WDCR ;Disable Watchdog if VCCP=5V
        KICK_DOG        ;Reset Watchdog counter
        LDP     #00E0h
        SPLK   #00BBh, CKCR1 ;CLKIN(XTAL)=10MHz, CPUCLK=20MHz
        SPLK   #00C3h, CKCR0 ;CLKMD=PLL Enable, SYSCLK=CPUCLK/2,
        SPLK   #40C0h, SYSCR ;CLKOUT=CPUCLK
        LDP     #0000h
        SPLK   #4h, GPR0
        OUT    GPR0, WSGR   ;Set XMIF to run w/no wait states
;=====
; Initialize B2 RAM to zero's.
;=====
        LAR     AR2, #B2_SADDR ; AR2 -> B2 start address
        MAR    *, AR2        ; Set ARP=AR2
        LA    CL    #0        ; Set ACC = 0
        RPT    #1fh         ; Set repeat cntr for 31+1 loops
        SACL   *+           ; Write zeros to B2 RAM
;=====
; Initialize DATAOUT with data to be transmitted.
;=====
        LAR     AR2, #B2_SADDR ; Reset AR2 -> B2 start address
        LAR     AR1, #DATA_OUT ; AR1 -> DATAOUT start address
        RPT    #04h         ; set repeat counter for 4+1 loops
        BLPD   #TXDATA, *+   ; loads B2 with TXDATA

```

Example 8–1. Asynchronous Communication Routine (Continued)

```

;=====
; INITIALIZATION OF INTERRUPT DRIVEN SCI ROUTINE
;=====
SCI_INIT:    LDP    #00E0h
             SPLK   #0037h, SCICCR ;1 stop bit,odd parity,8 char bits,
             ;async mode, idle-line protocol
             SPLK   #0013h, SCICTL1 ;Enable TX, RX, internal SCICLK,
             ;Disable RX ERR, SLEEP, TXWAKE
             SPLK   #0002h, SCICTL2 ;Enable RX INT,disable TX INT
             SPLK   #0000h, SCIHBAUD
             SPLK   #0040h, SCILBAUD ;Baud Rate=19200 b/s (10 MHz SYSCLK)
             SPLK   #0022h, SCIPC2  ;Enable TXD & RXD pins
             SPLK   #0033h, SCICTL1 ;Relinquish SCI from Reset.
             LAR    AR0, #SCITXBUF  ;Load AR0 with SCI_TX_BUF address
             LAR    AR1, #SCIRXBUF  ;Load AR1 with SCI_RX_BUF address
             LAR    AR2, #B2_SADDR  ;Load AR2 with TX data start address
             LDP    #0
             LACC   IFR              ;Load ACC with Interrupt flags
             SACL   IFR              ;Clear all pending interrupt flags
             SPLK   #0001h,IMR      ;Unmask interrupt level INT1
             CLRC   INTM             ;Enable interrupts

;=====
; Main Program Routine
;=====
MAIN:                ;Main loop of code begins here
                    ;insert actual code here

                    NOP
                    NOP
                    NOP
;                    .... ;insert actual code here
                    B    MAIN      ;The MAIN program loop has completed
                    ;one pass, branch back to the
                    ;beginning and continue.

;=====
; I S R - INT1_ISR
;
; Description: The INT1_ISR first determines if the SCI RXINT caused
; the interrupt. If so, the SCI Specific ISR reads the
; character in the RX buffer. If the character received
; corresponds to a carriage return, <CR>, the character
; string "Ready" is transmitted. If the character
; received does NOT correspond to a carriage return,
; <CR>, then the ISR returns to the main program
; without transmitting a character string. If the
; SCI RXINT did not cause an interrupt, then the value
; '0x0bad' is stored in the accumulator and program
; gets caught in the BAD_INT endless loop.
;=====

```

Example 8-1. Asynchronous Communication Routine (Continued)

```

INT1_ISR:      LDP      #00E0h
               LACL     SYSIVR      ;Load peripheral INT vector address
               SUB      #0006h      ;Subtract RXINT offset from above
               BCND     SCI_ISR,EQ   ;verify RXINT initiated interrup
    B          BAD_INT      ;Else, bad interrupt occurred
SCI_ISR:      MAR      *,AR1        ;Set ARP=AR1
               LACC     *,AR2        ;Load ACC w/RX buffer character
               SUB      #000Dh      ;Check if <CR> has been pressed:
               BCND     XMIT_CHAR, EQ ;YES? Transmit data.
    B          ISR_END      ;NO? Return from INT1_ISR.
XMIT_CHAR:    LACC     ++,AR0        ;Load char to be xmitted into ACC
               BCND     ISR_END,EQ   ;Check for Null Character
               ;YES? Return from INT1_ISR.
               SACL     *,AR2        ;NO? Load char into xmit buffer.
XMIT_RDY:    BIT       SCICTL2, BIT7 ;Test TXRDY bit
               BCND     XMIT_RDY, NTC ;If TXRDY=0,then repeat loop
    B          XMIT_CHAR      ;else xmit next character
ISR_END:     LAR       AR2, #B2_SADDR ;Reload AR2 w/ TX data start address
               CLRC     INTM        ;Clear INT Mask flag
               RET       ;Return from INT1_ISR
BAD_INT:     LACC     #0BADh        ;Load ACC with "bad"
    B          BAD_INT      ;Repeat loop
;=====
; I S R - PHANTOM
;
; Description:      Dummy ISR, used to trap spurious interrupts.
;=====
PHANTOM:     B          PHANTOM
    
```

Serial Peripheral Interface (SPI) Module

The serial peripheral interface (SPI) is a high-speed synchronous serial input/output (I/O) port that allows a serial bit stream of programmed length (one to eight bits) to be shifted into and out of the device at a programmed bit-transfer rate. This chapter discusses the architecture, functions, and programming of the SPI module.

Note: 8-Bit Peripheral

This module is interfaced to the 16-bit peripheral bus as an 8-bit peripheral. Therefore, reads from bits 15–8 are undefined; writes to bits 15–8 have no effect.

Topic	Page
9.1 SPI Overview	9-2
9.2 SPI Operation	9-6
9.3 SPI Control Registers	9-17
9.4 SPI Operation-Mode Initialization Examples	9-34

9.1 SPI Overview

The SPI is normally used for communications between the DSP controller and external peripherals or another controller. Typical applications include external I/O or peripheral expansion via devices such as shift registers, display drivers, and analog-to-digital converters (ADCs).

Notes: Register Bit Notation, 8-Bit Peripheral

For convenience, references to a bit in a register are abbreviated using the register name followed by a period and the number of the bit. For example, the notation for bit 7 of the SPI emulation buffer register (SPIEMU) is SPIEMU.7.

Because the SPI module is interfaced to the 16-bit peripheral bus as an 8-bit peripheral, reads from bits 15–8 are undefined; writes to bits 15–8 have no effect.

9.1.1 SPI Physical Description

The 4-pin SPI module shown in Figure 9–1, *4-Pin SPI Module Block Diagram (Slave Mode)*, on page 9-3 consists of:

- Four I/O pins:
 - SPISIMO (SPI slave in, master out) controlled by bits in SPIPC2
 - SPISOMI (SPI slave out, master in) controlled by bits in SPIPC2
 - SPICLK (SPI clock) controlled by bits in SPIPC1
 - SPISTE (SPI strobe) controlled by bits in SPIPC1
- Master and slave mode operations
- SPI serial input buffer register (SPIBUF). This buffer register contains the data that is received from the network and ready for the CPU to read.
- SPI serial data register (SPIDAT). This data shift register serves as the transmit/receive shift register.
- SPICLK phase and polarity control
- State control logic
- Memory-mapped control and status registers

The basic function of the strobe (SPISTE) pin is to enable transmission for the SPI module in slave mode. It prevents the shift register from transmitting by placing the SOMI pin in a 3-state mode. When the SPI is in the master mode, the SPISTE pin always operates as a general-purpose digital I/O pin and can function as the SPI slave module select line. For additional information see section 9.3.8, *Serial Port Control Register 1*, on page 9-29 and section 9.3.9, *Serial Port Control Register 2*, on page 9-31.

Figure 9–1. 4-Pin SPI Module Block Diagram (Slave Mode)

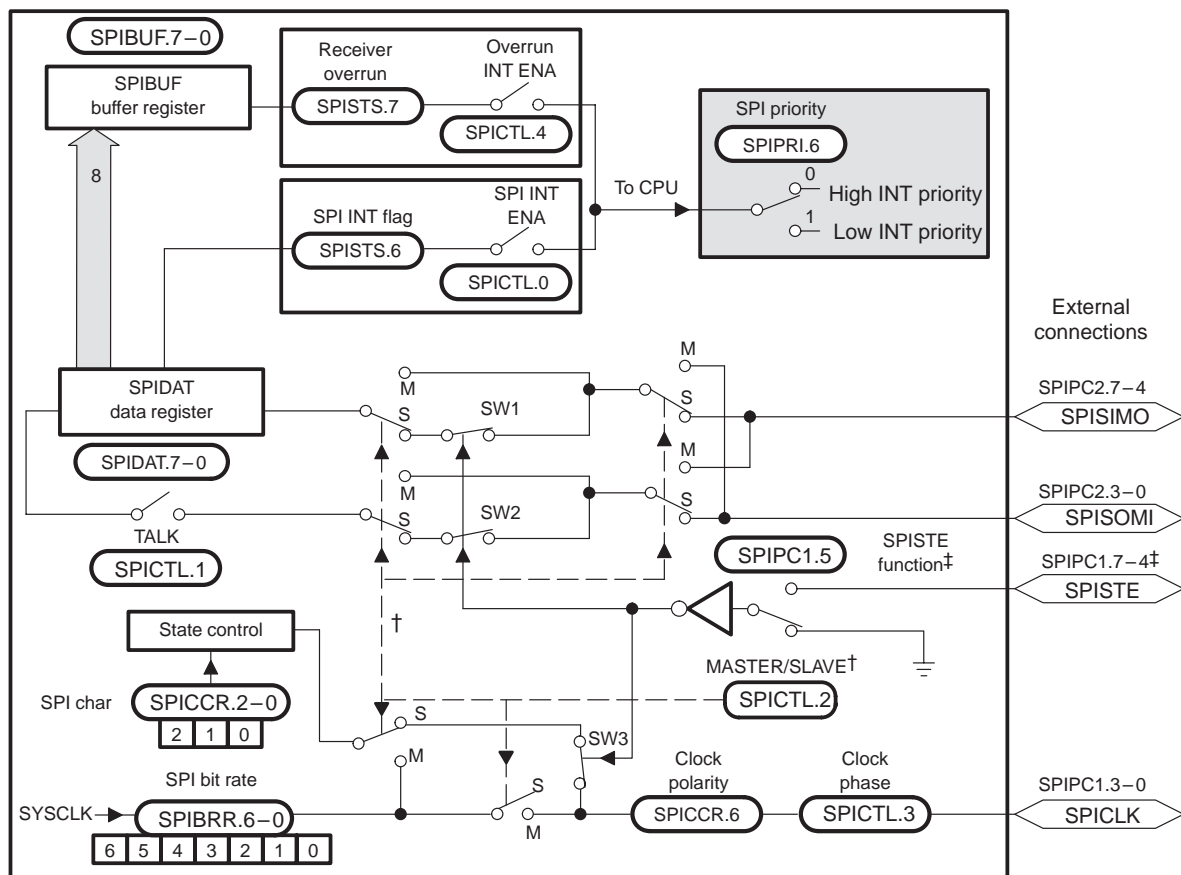

† The diagram is shown in slave mode.

‡ The SPISTE pin is shown as being disabled, meaning the data can be transmitted or received in this mode. Note that switches SW1, SW2, and SW3 are closed in this configuration.

9.1.2 SPI Control Registers

SPI operations are controlled by ten registers inside the SPI module (see Table 9–1, *Addresses of SPI Control Registers*, on page 9-5). They are:

- SPICCR (SPI configuration control register). Contains the following control bits used for SPI configuration:
 - SPI module software reset
 - SPICLK polarity selection
 - Three SPI character-length control bits
- SPICTL (SPI operation control register). Contains the following control bits for data transmission:
 - Two SPI interrupt-enable bits
 - SPICLK phase selection
 - Operational mode (master/slave)
 - Data transmission enable
- SPISTS (SPI status register). Contains the following two receiver buffer status bits:
 - RECEIVER OVERRUN
 - SPI INT FLAG
- SPIBRR (SPI baud rate register). Contains seven bits that determine the bit transfer rate
- SPIEMU (SPI emulation buffer register). Contains the received data and supports correct emulation; the SPIBUF is used for normal operation
- SPIBUF (SPI serial input buffer register). Contains the received data
- SPIDAT (SPI serial data register). Contains data transmitted by the SPI acting as the transmit/receive shift register. Data written to SPIDAT is shifted out on subsequent SPICLK cycles. For every bit shifted out of the SPI, a bit is shifted into the other end of the shift register
- SPIPC1 (SPI port control register 1). Contains control bits to select the functions of the SPISTE pin and the SPICLK pin
- SPIPC2 (SPI port control register 2). Contains control bits to select the functions of the SPISIMO and SPISOMI pins
- SPIPRI (SPI priority control register). Contains two bits that specify interrupt priority and determine SPI operation on the XDS emulator during program suspensions

Table 9–1. Addresses of SPI Control Registers

Address	Register	Name	Described in	
			Section	Page
7040h	SPICCR	SPI configuration control register	9.3.1	9-18
7041h	SPICTL	SPI operation control register	9.3.2	9-20
7042h	SPISTS	SPI status register	9.3.3	9-23
7043h		Reserved		
7044h	SPIBRR	SPI baud rate register	9.3.4	9-24
7045h		Reserved		
7046h	SPIEMU	SPI emulation buffer register	9.3.5	9-26
7047h	SPIBUF	SPI serial input buffer register	9.3.6	9-27
7048h		Reserved		
7049h	SPIDAT	SPI serial data register	9.3.7	9-28
704Ah		Reserved		
704Bh		Reserved		
704Ch		Reserved		
704Dh	SPIPC1	SPI port control register 1	9.3.8	9-29
704Eh	SPIPC2	SPI port control register 2	9.3.9	9-31
704Fh	SPIPRI	SPI priority control register	9.3.10	9-33

9.2 SPI Operation

This section describes the operating modes, interrupts, data format, clock sources, and initialization of the SPI, and shows typical timing diagrams for data transfers.

Note: Register Bit Naming Protocol

Reference to a bit in a register is abbreviated using the register acronym followed by a period and the bit number. For example, the MASTER/SLAVE bit of the SPI operation control register (SPICTL) is SPICTL.2.

9.2.1 Introduction to Operation

Figure 9–2, *SPI Master/Slave Connection (4–Pin Option)*, on page 9-7 shows typical connections of the SPI for communications between two controllers: a master and a slave.

The master initiates data transfer by sending the SPICLK signal. For both the slave and the master, data is shifted out of the shift registers on one edge of the SPICLK and latched into the shift register on the opposite SPICLK clock edge. If the CLOCK PHASE (bit SPICTL.3) bit is active, data is transmitted and received a half cycle before the SPICLK transition (see section 9.2.5, *Baud Rate and Clocking Schemes*, on page 9-11). As a result, both controllers send and receive data simultaneously. The application software determines if the data is meaningful data or dummy data. The three possible methods for data transmission are:

- Master sends data and slave sends dummy data
- Master sends data and slave sends data
- Master sends dummy data and slave sends data

The master can initiate data transfer at any time because it controls the SPICLK signal. The software, however, determines what the master detects when the slave is ready to broadcast data.

Figure 9–2. SPI Master/Slave Connection (4-Pin Option)

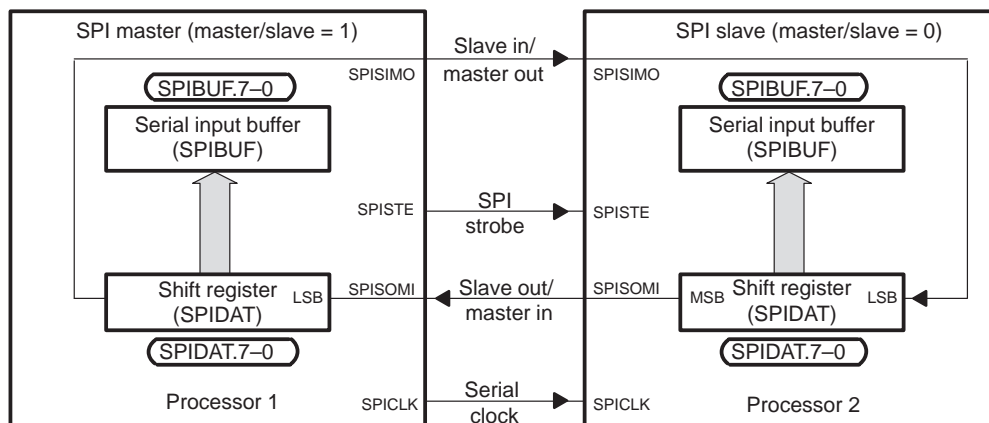

9.2.2 SPI Module Slave and Master Operation Modes

The SPI can operate in master or slave mode. The MASTER/SLAVE bit (SPICTL.2) selects the operating mode and the source of the SPICLK signal.

Master mode

In the master mode (MASTER/SLAVE = 1), the SPI provides the serial clock on the SPICLK pin for the entire serial communications network. Data is output on the SPISIMO pin and latched from the SPISOMI pin.

The SPIBRR determines both the transmit and receive bit transfer rate for the network. The SPIBRR can select 125 different data transfer rates.

Data written to SPIDAT initiates data transmission on the SPISIMO pin, most significant bit (MSB) first. Simultaneously, received data is shifted through the SPISOMI pin into the least significant bit (LSB) of SPIDAT. When the selected number of bits has been transmitted, the data is transferred, most significant bit (MSB) first, to the SPIBUF (buffered receiver) for the CPU to read. Data is stored right-justified in SPIBUF.

When the specified number of data bits has been shifted through SPIDAT, the following events occur:

- SPI INT FLAG bit (SPISTS.6) is set to 1.
- SPIDAT contents transfer to SPIBUF.
- If the SPI INT ENA bit (SPICTL.0) is set to 1, an interrupt is asserted.

In the master mode, the SPISTE pin always operates as a general-purpose I/O pin, regardless of the value of the SPISTE FUNCTION bit (SPIPC1.5). In a typical application, the SPISTE pin serves as a chip enable pin for slave SPI devices. (You must drive this slave select pin low before transmitting master data to the slave device, and drive this pin high again after transmitting the master data.)

Slave mode

In the slave mode (MASTER/SLAVE = 0), data shifts out on the SPISOMI pin and in on the SPISIMO pin. The SPICLK pin is used as the input for the serial shift clock, which is supplied from the external network master. The transfer rate is defined by this clock. The SPICLK input frequency should be no greater than the SYSCLK (system clock of the device) frequency divided by 8.

Data written to SPIDAT is transmitted to the network when the SPICLK signal is received from the network master. To receive data, the SPI waits for the network master to send the SPICLK signal and then shifts the data on the SPISIMO pin into SPIDAT. If data is to be transmitted by the slave simultaneously, it must be written to the SPIDAT before the beginning of the SPICLK signal.

When the TALK bit (SPICTL.1) is cleared, data transmission is disabled and the output line (SPISOMI) is put into the high-impedance state. This allows many slave devices to be tied together on the network, but only one slave at a time is allowed to talk.

In the slave mode, the SPISTE pin operates as a general-purpose I/O pin if the value of the SPISTE FUNCTION bit (SPIPC1.5) is cleared (0). The SPISTE pin operates as the slave select pin if SPIPC1.5 is set to 1. When the SPISTE pin is operating as the slave select pin, an active low signal on the SPISTE pin allows the slave SPI to transfer data to the serial data line; an inactive high signal causes the slave SPI's serial shift register to stop and its serial output pin to be put into the high-impedance state. This allows many slave devices to be tied together on the network, although only one slave device is selected at a time.

9.2.3 SPI Interrupts

Four control bits are used to initialize the SPI's interrupts:

- SPI INT ENA bit (SPICTL.0)
- SPI INT FLAG bit (SPISTS.6)
- OVERRUN INT ENA bit (SPICTL.4)
- RECEIVER OVERRUN flag bit (SPISTS.7)

SPI interrupt enable bit (SPICTL.0)

When the SPI interrupt enable bit is set and an interrupt condition occurs, the corresponding interrupt is asserted.

- 0 = Disable SPI interrupts
- 1 = Enable SPI interrupts

SPI interrupt flag bit (SPISTS.6)

This status flag indicates that a character has been placed in the SPI receiver buffer and is ready to be read.

When a complete character has been shifted into or out of SPIDAT, the SPI INT FLAG bit (SPISTS.6) is set, and an interrupt is generated if enabled by the SPI INT ENA bit. The interrupt flag remains set until it is cleared by one of the following four events:

- The CPU reads the SPIBUF (reading the SPIEMU does not clear the SPI INT FLAG).
- The CPU enters the OSC power-down or PLL power-down mode with an IDLE instruction.
- Software sets the SPI SW RESET bit (SPICCR.7, see Figure 9–8, *SPI Configuration Control Register (SPICCR)*, on page 9-18).
- A system reset occurs.

To avoid the generation of another interrupt, an interrupt request must be explicitly cleared by one of the four methods listed above. An interrupt request can be temporarily disabled by clearing the SPI INT ENA bit. Unless the SPI INT FLAG bit is cleared, however, the interrupt request is reasserted when the SPI INT ENA bit is again set to 1.

When the SPI INT FLAG bit is set, a character has been placed in the SPIBUF and is ready to be read. If the CPU does not read the character by the time the next complete character has been received, the new character is written into SPIBUF and the RECEIVER OVERRUN flag bit (SPISTS.7) is set.

OVERRUN interrupt enable bit (SPICTL.4)

Setting the overrun interrupt enable bit allows the assertion of an interrupt whenever the RECEIVER OVERRUN flag bit (SPISTS.7) is set by hardware. Interrupts generated by SPISTS.7 and by the SPI INT FLAG (SPISTS.6) bit share the same interrupt vector.

- 0 = Disable RECEIVER OVERRUN flag bit interrupts
- 1 = Enable RECEIVER OVERRUN flag bit interrupts

RECEIVER OVERRUN flag bit (SPISTS.7)

The RECEIVER OVERRUN flag bit is set whenever a new character has been received and loaded into the SPIBUF before the previously received character has been read from the SPIBUF. The RECEIVER OVERRUN flag bit must be cleared by software.

9.2.4 Data Format

Three bits (SPICCR.2-0) specify the number of bits (one to eight) in the data character. This information directs the state control logic to count the number of bits received or transmitted to determine when a complete character has been processed. The following applies to characters with fewer than eight bits:

- Data must be left justified when written to SPIDAT.
- Data read back from SPIBUF is right justified.
- SPIBUF contains the most recently received character, right justified, plus any bits that remain from previous transmissions that have been shifted to the left (shown in Example 9–1).

Example 9–1. Transmission of Bit from SPIBUF

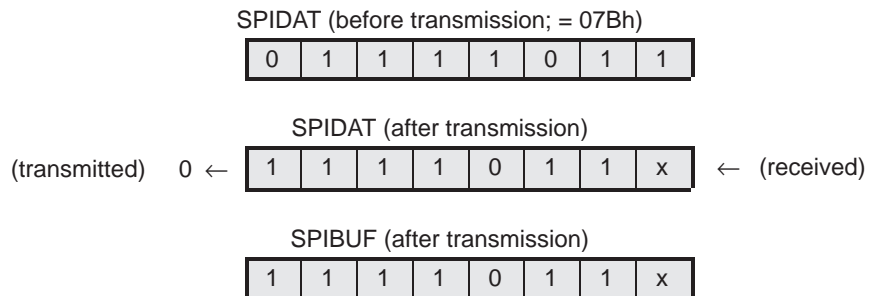

Note: 1) x = 1 if SPISOMI data is high; x = 0 if SPISOMI data is low; master mode is assumed.
 2) Transmission character length = 1 bit (specified in bits SPICCR.2-0)

9.2.5 Baud Rate and Clocking Schemes

The SPI module supports 125 different baud rates and four different clock schemes. Depending on whether the SPI clock is in the slave or master mode, the SPICLK pin can receive an external SPI clock signal or provide the SPI clock signal, respectively.

- In the slave mode, the SPI clock is received on the SPICLK pin from the external source and can be no greater than the SYSCLK frequency divided by 8.
- In the master mode, the SPI clock is generated by the SPI and is output on the SPICLK pin.

Baud-rate determination

Equation 9–1 shows how to determine SPI baud rates.

Equation 9–1. SPI Baud-Rate Calculations

- For SPIBRR = 3 to 127:

$$SPI \text{ Baud Rate} = \frac{SYSCLK}{(SPIBRR + 1)}$$

- For SPIBRR = 0, 1, or 2:

$$SPI \text{ Baud Rate} = \frac{SYSCLK}{4}$$

where:

SYSCLK = System clock frequency of the device

SPIBRR = Contents of the SPIBRR in the master SPI device

To determine what value to load into SPIBRR, you must know the device system clock (SYSCLK) frequency (which is device/user-specific) and the baud rate at which you will be operating.

Example 9–2, *Maximum Baud-Rate Calculation*, on page 9-12 shows how to determine the maximum baud rate at which a 'C240 can communicate. Assume that SYSCLK = 10 MHz.

Example 9–2. Maximum Baud-Rate Calculation

$$\begin{aligned} \text{SPI Baud Rate} &= \frac{\text{SYSCLK}}{(\text{SPIBRR} + 1)} \\ &= \frac{10 \times 10^6}{(\text{SPIBRR} + 1)} \\ &= \frac{10 \times 10^6}{(3 + 1)} \\ &= \frac{10 \times 10^6}{4} \\ &= 2.5 \times 10^6 = 2.5 \text{ Mbps} \end{aligned}$$

The maximum master SPI baud rate is 2.5 Mbps. However, the SPI slave baud data has a maximum speed of 1.25 Mbps (SYSCLK/8).

SPI clocking schemes

Control of the four different clocking schemes on the SPICLK pin is handled by the CLOCK POLARITY bit (SPICCR.6 in Figure 9–8, *SPI Configuration Control Register (SPICCR)*, on page 9-18) and the CLOCK PHASE bit (SPICTL.3 in Figure 9–9, *SPI Operation Control Register (SPICTL)*, on page 9-20). The CLOCK POLARITY bit selects the active edge of the clock, either rising or falling. The CLOCK PHASE bit selects a half-cycle delay of the clock. The four different clocking schemes are as follows:

- Falling Edge Without Delay.** The SPI transmits data on the falling edge of the SPICLK and receives data on the rising edge of the SPICLK.
- Falling Edge With Delay.** The SPI transmits data one half-cycle ahead of the falling edge of the SPICLK signal and receives data on the falling edge of the SPICLK signal.
- Rising Edge Without Delay.** The SPI transmits data on the rising edge of the SPICLK signal and receives data on the falling edge of the SPICLK signal.
- Rising Edge With Delay.** The SPI transmits data one half-cycle ahead of the rising edge of the SPICLK signal and receives data on the rising edge of the SPICLK signal.

Table 9–2 shows the selection procedure for the SPI clocking scheme. Examples of the four clocking schemes, relative to transmitted and received data, are shown in Figure 9–3.

Table 9–2. SPI Clocking Scheme Selection Guide

SPICLK Scheme	CLOCK POLARITY (SPICCR.6)	CLOCK PHASE (SPICTL.3)
Rising edge without delay	0	0
Rising edge with delay	0	1
Falling edge without delay	1	0
Falling edge with delay	1	1

Figure 9–3. SPICLK Signal Options

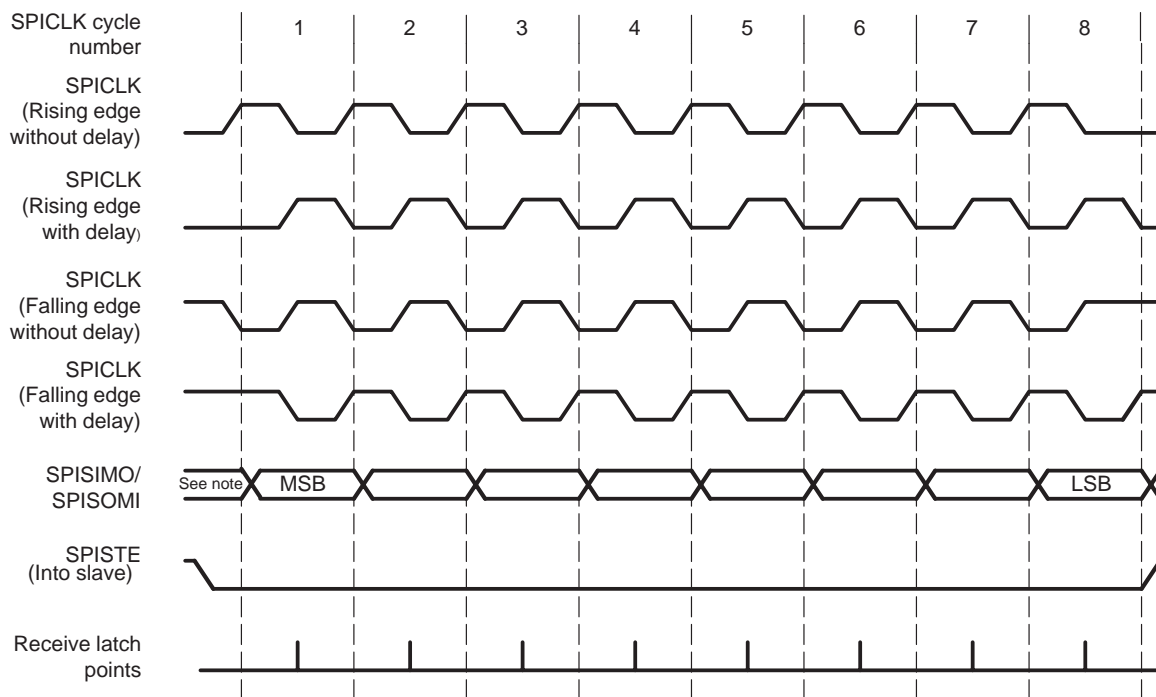

Note: Previous data bit

For the SPI, the SPICLK symmetry is retained only when the result of (SPIBRR + 1) is an even value. When (SPIBRR + 1) is an odd value and SPIBRR is greater than 3, the SPICLK becomes asymmetrical. The low pulse of the SPICLK is one SYSCLK longer than the high pulse when the CLOCK POLARITY bit is clear (0) as shown in Figure 9–4. When the CLOCK POLARITY bit is set to 1, the high pulse of the SPICLK is one SYSCLK longer than the low pulse as shown in the same figure.

Figure 9–4. SPI: SPICLK-SYSCLK Characteristic when (BRR + 1) is Odd, BRR > 3, and CLOCK POLARITY = 1

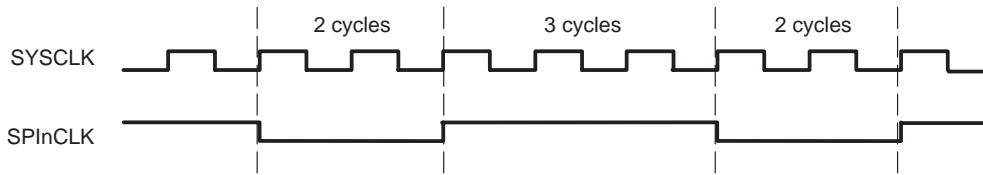

9.2.6 Initialization Upon Reset

A system reset forces the SPI peripheral module into the following default configuration:

- The unit is configured as a slave module (MASTER/SLAVE = 0).
- The transmit capability is disabled (TALK = 0).
- Data is latched at the input on the falling edge of the SPICLK signal.
- Character length is assumed to be one bit.
- The SPI interrupts are disabled.
- Data in SPIDAT is reset to 00h.
- Pin functions are selected as general-purpose inputs.

To change this SPI configuration:

- 1) Set the SPI SW RESET bit (SPICCR.7 on page 9-18) to 1.
- 2) Initialize the SPI configuration, format, baud rate, and pin functions as desired.
- 3) Clear the SPI SW RESET bit.

Note: Proper SPI Initialization Using the SPI SW RESET Bit

To prevent unwanted and unforeseen events from occurring during, or as a result of, initialization changes, set the SPI SW RESET bit (SPICCR.7 in Figure 9–8 on page 9-18) before making initialization changes and then clear this bit after the initialization is complete.

- 4) Write to SPIDAT (this initiates the communication process in the master).
- 5) Read SPIBUF after the data transmission is complete (SPISTS.6 = 1) to determine what data was received.

9.2.7 Data Transfer Example

The two timing diagrams shown in Figure 9–5 below, and Figure 9–6 on page 9-16 illustrate an SPI data transfer between two devices using a character length of five bits with a symmetrical SPICLK.

The timing diagram with an unsymmetrical SPICLK (Figure 9–4 on page 9-14) shares similar characterizations with Figure 9–5 and Figure 9–6 except that the data transfer is one SYSCLK cycle longer per bit during the low pulse (CLOCK POLARITY = 0) or during the high pulse (CLOCK POLARITY = 1) of the SPICLK.

Figure 9–5. Signals Connecting to Master Processor

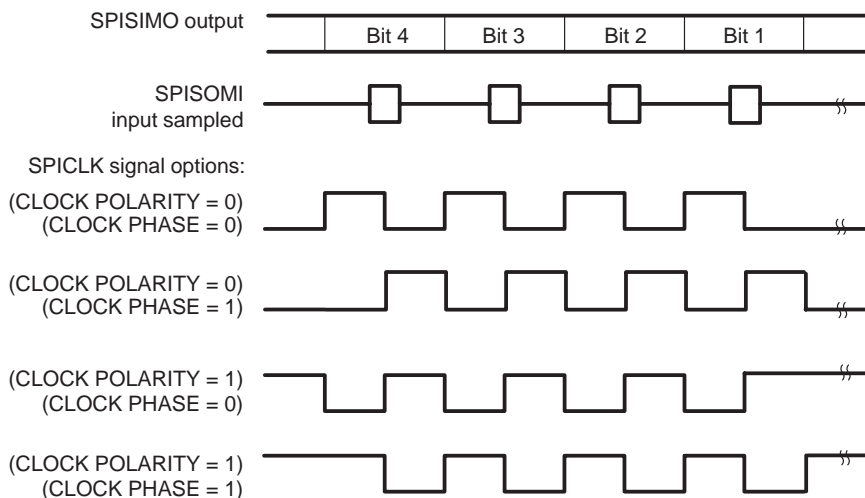
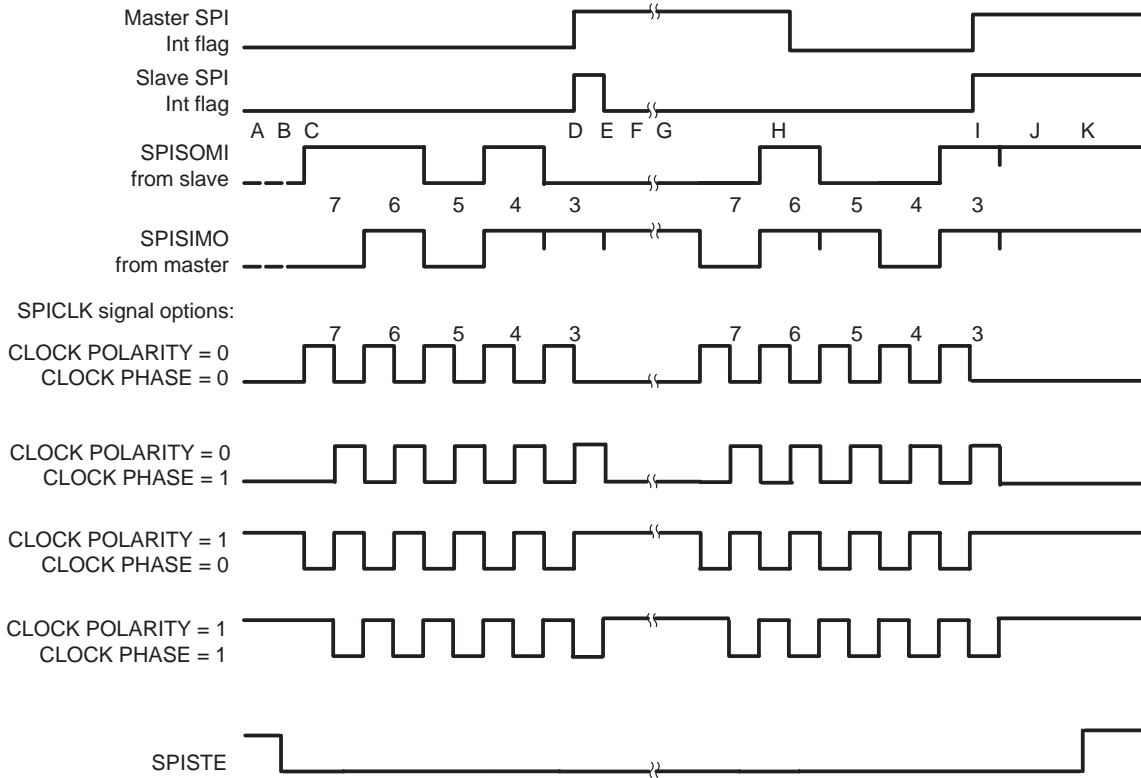

Figure 9–6. Five Bits per Character



- A. Slave writes 0D0h to SPIDAT and waits for the master to shift out the data.
- B. Master sets the slave SPISTE signal low (active).
- C. Master writes 058h to SPIDAT, which starts the transmission procedure.
- D. First byte is finished and sets the interrupt flags.
- E. Slave reads 0Bh from its SPIBUF (right justified).
- F. Slave writes 04Ch to SPIDAT and waits for the master to shift out the data.
- G. Master writes 06Ch to SPIDAT, which starts the transmission procedure.
- H. Master reads 01Ah from the SPIBUF (right justified).
- I. Second byte is finished and sets the interrupt flags.
- J. Master reads 89h and the slave reads 8Dh from their respective SPIBUF. After the user's software masks off the unused bits, the master receives 09h and the slave receives 0Dh.
- K. Master clears the slave SPISTE signal high (inactive).

9.3 SPI Control Registers

The SPI is controlled and accessed through registers in the control register file. These registers are shown in Figure 9–7 and described in Section 9.3.1, *SPI Configuration Control Register (SPICCR)*, on page 9-18 and Section 9.3.2, *SPI Operation Control Register (SPICTL)*, on page 9-20.

Figure 9–7. SPI Control Registers

Address	Register	Bit number							
		7	6	5	4	3	2	1	0
7040h	SPICCR	SPI SW RESET	CLOCK POLARITY	Reserved			SPI CHAR2	SPI CHAR1	SPI CHAR0
7041h	SPICTL	Reserved			OVERRUN INT ENA	CLOCK PHASE	MASTER/SLAVE	TALK	SPI INT ENA
7042h	SPISTS	RECEIVER OVERRUN	SPI INT FLAG	Reserved					
7043h	—	Reserved							
7044h	SPIBRR	Reserved	SPI BIT RATE 6	SPI BIT RATE 5	SPI BIT RATE 4	SPI BIT RATE 3	SPI BIT RATE 2	SPI BIT RATE 1	SPI BIT RATE 0
7045h	—	Reserved							
7046h	SPIEMU	ERCVD7	ERCVD6	ERCVD5	ERCVD4	ERCVD3	ERCVD2	ERCVD1	ERCVD0
7047h	SPIBUF	RCVD7	RCVD6	RCVD5	RCVD4	RCVD3	RCVD2	RCVD1	RCVD0
7048h	—	Reserved							
7049h	SPIDAT	SDAT7	SDAT6	SDAT5	SDAT4	SDAT3	SDAT2	SDAT1	SDAT0
704Ah	—	Reserved							
704Bh	—	Reserved							
704Ch	—	Reserved							
704Dh	SPIPC1	SPISTE DATA IN	SPISTE DATA OUT	SPISTE FUNCTION	SPISTE DATA DIR	SPICLK DATA IN	SPICLK DATA OUT	SPICLK FUNCTION	SPICLK DATA DIR
704Eh	SPIPC2	SPISIMO DATA IN	SPISIMO DATA OUT	SPISIMO FUNCTION	SPISIMO DATA DIR	SPISOMI DATA IN	SPISOMI DATA OUT	SPISOMI FUNCTION	SPISOMI DATA DIR
704Fh	SPIPRI	Reserved	SPI PRIORITY	SPI ESPEN	Reserved				

9.3.1 SPI Configuration Control Register (SPICCR)

The SPI configuration control register (SPICCR) controls the setup of the SPI for operation.

Figure 9–8. SPI Configuration Control Register (SPICCR) — Address 7040h

7	6	5 – 3	2	1	0
SPI SW RESET	CLOCK POLARITY	Reserved	SPI CHAR2	SPI CHAR1	SPI CHAR0
RW–0	RW–0		RW–0	RW–0	RW–0

Note: R = read access, w = write access, –0 = value after reset

Bit 7 **SPI SW RESET.** SPI software reset. When changing configuration, set this bit before the changes and clear it before resuming operation. (See section 9.2.6, *Initialization Upon Reset*, on page 9-14.)

1 = Initializes the SPI operating flags to the reset condition

Specifically, the RECEIVER OVERRUN flag bit (SPISTS.7) and the SPI INT FLAG bit (SPISTS.6) are cleared. The SPI configuration remains unchanged. If the module is operating as a master, the SPICLK signal output returns to its inactive level.

0 = SPI is ready to transmit or receive the next character

When the SPI SW RESET bit is 1, a character written to the transmitter will not be shifted out when this bit clears. A new character must be written to the serial data register.

Bit 6 **CLOCK POLARITY.** Shift clock polarity. This bit controls the polarity of the SPICLK signal. CLOCK POLARITY and CLOCK PHASE (SPICTL.3) control four clocking schemes on the SPICLK pin. See section 9.2.5, *Baud Rate and Clocking Schemes* on page 9-11, and Figure 9–10, *SPICLK Signal Options*, on page 9-22.

0 = Inactive level is low

The data input and output edges depend on the value of the CLOCK PHASE bit (SPICTL.3) as follows:

- CLOCK PHASE = 0: Data is output on the rising edge of the SPICLK signal; input data is latched on the falling edge of the SPICLK signal.
- CLOCK PHASE = 1: Data is output one-half cycle before the first rising edge of the SPICLK signal and on subsequent falling edges of the SPICLK signal; input data is latched on the rising edge of the SPICLK signal.

1 = Inactive level is high

The data input and output edges depend on the value of the CLOCK PHASE bit (SPICTL.3) as follows:

- CLOCK PHASE = 0: Data is output on the falling edge of the SPICLK signal; input data is latched on the rising edge of the SPICLK signal.
- CLOCK PHASE = 1: Data is output one half cycle before the first falling edge of the SPICLK signal and on subsequent rising edges of the SPICLK signal; input data is latched on the falling edge of the SPICLK signal.

Bits 5–3 **Reserved.** Reads are indeterminate; writes have no effect.

Bits 2–0 **SPI CHAR2–SPI CHAR0.** Character length control bits 2–0. These three bits determine the number of bits to be shifted in or out as a single character during one shift sequence. Table 9–3 lists the character length selected by the bit values.

Table 9–3. Character Length Control Bit Values

SPI CHAR2	SPI CHAR1	SPI CHAR0	Character Length
0	0	0	1
0	0	1	2
0	1	0	3
0	1	1	4
1	0	0	5
1	0	1	6
1	1	0	7
1	1	1	8

9.3.2 SPI Operation Control Register (SPICTL)

The SPI operation control register (SPICTL) controls the following:

- Data transmission
- The SPI's ability to generate interrupts
- The SPICLK phase
- The operating mode (slave or master)

Figure 9–9. SPI Operation Control Register (SPICTL) — Address 7041h

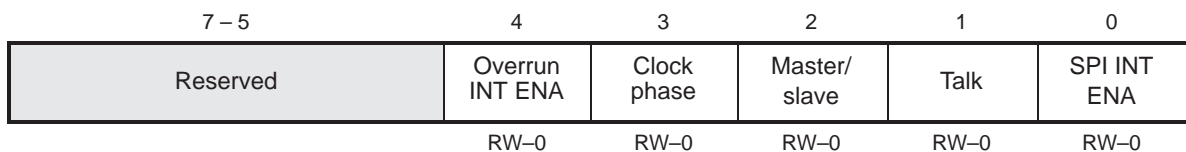

Note: R = read access, W = write access, –0 = value after reset

Bits 7–5 **Reserved.** Reads are indeterminate; writes have no effect.

Bit 4 **OVERRUN INT ENA.** Overrun interrupt enable. Setting this bit (OVERRUN INTERRUPT ENABLE) causes an interrupt to be generated when the RECEIVER OVERRUN flag bit (SPISTS.7 in Figure 9–11, *SPI Status Register (SPISTS)*, on page 9-23) is set by hardware. Interrupts generated by the RECEIVER OVERRUN flag bit and the SPI INT FLAG bit (SPISTS.6) share the same interrupt vector.

- 0 = Disable RECEIVER OVERRUN flag bit (SPISTS.7) interrupts
- 1 = Enable RECEIVER OVERRUN flag bit (SPISTS.7) interrupts

Bit 3 **CLOCK PHASE.** SPI Clock Phase Select. This bit controls the phase of the SPICLK signal.

- 0 = Normal SPI clocking scheme, depending on the CLOCK POLARITY bit (SPICCR.6 in Figure 9–8, *SPI Configuration Control Register*, on page 9-18)
- 1 = SPICLK signal delayed by one half-cycle, polarity determined by the CLOCK POLARITY bit

CLOCK PHASE and CLOCK POLARITY bits make four different clocking schemes possible. See section 9.2.5, *Baud Rate and Clocking Schemes* on page 9-11, section 9.3.1, *SPI Configuration Control Register (SPICCR)* on page 9-18, and Figure 9–10, *SPICLK Signal Options* on page 9-22.

When operating with CLOCK PHASE high, the SPI (master or slave) makes the first bit of data available after SPIDAT is written and before the first edge of the SPICLK signal, regardless of which SPI mode is being used.

Bit 2 **MASTER/SLAVE.** SPI network mode control. This bit determines whether the SPI is a network master or slave. During reset initialization, the SPI is automatically configured as a network slave.

- 0 = SPI configured as a slave
- 1 = SPI configured as a master

Bit 1 **TALK.** Master/slave transmit enable. The TALK bit can disable data transmission (master or slave) by placing the serial data output in the high-impedance state. If this bit is disabled during a transmission, the transmit shift register continues to operate until the previous character is shifted out. When the TALK bit is disabled, the SPI can still receive characters and update the status flags. TALK is cleared (disabled) by a system reset.

- 0 = Disables transmission:

Slave mode operation: If not previously configured as a general-purpose I/O pin, the SPISOMI pin is put in the high-impedance state.

Master mode operation: If not previously configured as a general-purpose I/O pin, the SPISIMO pin is put in the high-impedance state.

- 1 = Enables transmission

For the four-pin option, make sure you enable the receiver's SPISTB input pin.

Bit 0 **SPI INT ENA.** SPI Interrupt Enable. This bit controls the SPI's ability to generate an interrupt. The SPI INT FLAG bit (SPISTS.6) is unaffected by this bit.

- 0 = Disables interrupt
- 1 = Enables interrupt

Figure 9–10. SPICLK Signal Options

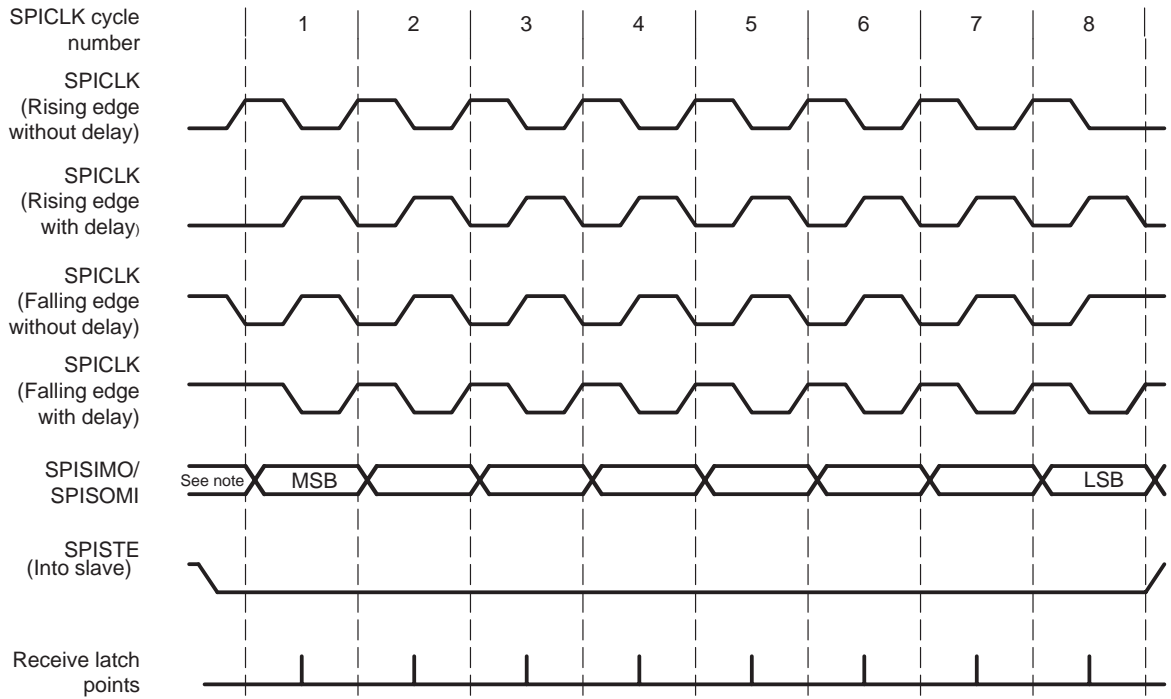

Note: Previous data bit

9.3.3 SPI Status Register (SPISTS)

The SPISTS contains the receive buffer status bits shown in Figure 12–11.

Figure 9–11. SPI Status Register (SPISTS) — Address 7042h

7	6	5 – 0
Receiver Overrun	SPI INT flag	Reserved
RC–0	R–0	

Note: R = read access, C = clear, –0 = value after reset

Bit 7

RECEIVER OVERRUN. SPI receiver overrun flag. This bit is a read/clear only flag. The SPI hardware sets this bit when a receive or transmit operation completes before the previous character has been read from the buffer. The bit indicates that the last received character has been overwritten and is lost. The SPI requests one interrupt sequence each time this bit is set if the OVERRUN INT ENA bit (SPICCTL.4 on page 9-20) is set high. The bit is cleared in one of three ways:

- Writing a 0 to this bit
- Writing a 1 to SPI SW RESET (SPICCR.7 on page 9-18)
- Resetting the system

If the OVERRUN INT ENA bit (SPICCTL.4) is set, the SPI requests only one interrupt each time an overrun condition occurs. In other words, if the RECEIVER OVERRUN flag bit is left set (not cleared) by the interrupt service routine, another overrun interrupt will not be immediately reentered when the interrupt service routine is exited. An interrupt is requested each time an overrun condition occurs if the OVERRUN INT ENA bit is enabled, regardless of the previous condition of the RECEIVER OVERRUN flag bit.

However, the RECEIVER OVERRUN flag bit should be cleared during the interrupt service routine because the RECEIVER OVERRUN flag bit and SPI INT FLAG bit share the same interrupt vector. This will alleviate any possible doubt as to the source of the interrupt when the next byte is received.

Bit 6 **SPI INT FLAG.** SPI interrupt flag. SPI INT FLAG is a read-only flag. The SPI hardware sets this bit to indicate that it has completed sending or receiving the last bit and is ready to be serviced. The received character is placed in the receiver buffer at the same time this bit is set. This flag causes an interrupt to be requested if the SPI INT ENA bit (SPICTL.0 on page 9-21) is set. This bit is cleared in one of three ways:

- Reading SPIBUF
- Writing a 1 to SPI SW RESET (SPICCR.7 on page 9-18)
- Resetting the system

Bits 5–0 **Reserved.** Reads are indeterminate, and writes have no effect.

9.3.4 SPI Baud Rate Register (SPIBRR)

The SPIBRR contains the bits used for baud-rate calculation.

Figure 9–12. SPI Baud Rate Register (SPIBRR) — Address 7044h

	7	6	5	4	3	2	1	0
Reserved	SPI bit rate 6	SPI bit rate 5	SPI bit rate 4	SPI bit rate 3	SPI bit rate 2	SPI bit rate 1	SPI bit rate 0	
	RW–0	RW–0	RW–0	RW–0	RW–0	RW–0	RW–0	RW–0

Note: R = read access, W = write access, –0 = value after reset

Bit 7 **Reserved.** Reads are indeterminate; writes have no effect.

Bits 6–0 **SPI BIT RATE 6–SPI BIT RATE 0.** SPI bit rate (baud) control. These bits determine the bit transfer rate if the SPI is the network master. There are 125 data transfer rates (each a function of the system clock) that can be selected. One data bit is shifted per SPICLK cycle.

If the SPI is a network slave, the module receives a clock on the SPICLK pin from the network master; therefore, these bits have no effect on the SPICLK signal. The frequency of the input clock from the master should not exceed the slave SPI’s SPICLK signal divided by 8.

In master mode, the SPI clock is generated by the SPI and is output on the SPICLK pin. The SPI baud rates are determined by the formula in Equation 9–2.

Equation 9–2. SPI Baud Rate Calculation

- SPI Baud Rate for SPIBRR = 3 to 127:

$$\text{SPI Baud Rate} = \frac{\text{SYSCLK}}{(\text{SPIBRR} + 1)}$$

- SPI Baud Rate for SPIBRR = 0, 1, or 2:

$$\text{SPI Baud Rate} = \frac{\text{SYSCLK}}{4}$$

where:

SYSCLK = System clock frequency of the device

SPIBRR = Contents of the SPIBRR in the master SPI device

9.3.5 SPI Emulation Buffer Register (SPIEMU)

The SPIEMU contains the received data. Reading the SPIEMU does not clear the SPI INT FLAG bit (SPISTS.6 on page 9-24).

Figure 9–13. SPI Emulation Buffer Register (SPIEMU) — Address 7046h

7	6	5	4	3	2	1	0
ERCVD7	ERCVD6	ERCVD5	ERCVD4	ERCVD3	ERCVD2	ERCVD1	ERCVD0
R-x	R-x	R-x	R-x	R-x	R-x	R-x	R-x

Note: R = read access, -n = value after reset (x=indeterminate)

Bits 7–0 **ERCVD7–ERCVD0.** Emulation buffer received data. The SPIEMU functions almost identically to the SPIBUF, except that reading the SPIEMU does not clear the SPI INT FLAG bit (SPISTS.6 on page 9-24). Once the SPIDAT receives the complete character, the character is transferred to the SPIEMU and SPIBUF where it can be read. At the same time, the SPI INT FLAG is set.

This mirror register supports emulation. Reading the SPIBUF clears the SPI INT FLAG bit (SPISTS.6). In the normal operation of the emulator, control registers are read to continually update the contents of these registers on the display screen. The SPIEMU allows the emulator to read this register and properly update the contents on the display screen. Reading SPIEMU does not clear the SPI INT FLAG; reading SPIBUF clears this flag. SPIEMU enables the emulator to emulate the true operation of the SPI more accurately.

It is recommended that you read SPIBUF in the normal emulator run mode.

9.3.6 SPI Serial Input Buffer Register (SPIBUF)

The SPIBUF contains the received data. Reading the SPIBUF clears the SPI INT FLAG bit (SPISTS.6 on page 9-24).

Figure 9–14. SPI Serial Input Buffer Register (SPIBUF) — Address 7047h

7	6	5	4	3	2	1	0
RCVD7	RCVD6	RCVD5	RCVD4	RCVD3	RCVD2	RCVD1	RCVD0
R-x	R-x	R-x	R-x	R-x	R-x	R-x	R-x

Note: R = read access, -n = value after reset (x=indeterminate)

Bits 7–0 **RCVD7–RCVD0.** Received data. Once SPIDAT receives the complete character, the character is transferred to SPIBUF, where it can be read. At the same time, the SPI INT FLAG bit (SPISTS.6 on page 9-24) is set. Since data is shifted into the SPI's most significant bit (MSB) first, it is stored right justified in this register.

Note: Reading the SPIBUF

Reading SPIBUF clears the SPI INT FLAG bit (SPISTS.6 on page 9-24).

9.3.7 SPI Serial Data Register (SPIDAT)

The SPIDAT is the transmit/receive shift register. Data written to the SPIDAT is shifted out (MSB) on subsequent SPICLK cycles. For every MSB that is shifted out of the SPI, a bit is shifted into the LSB end of the shift register.

Figure 9–15. SPI Serial Data Register (SPIDAT) — Address 7049h

7	6	5	4	3	2	1	0
SDAT7	SDAT6	SDAT5	SDAT4	SDAT3	SDAT2	SDAT1	SDAT0
RW-x	RW-x	RW-x	RW-x	RW-x	RW-x	RW-x	RW-x

Note: R = read access, W = write access, -n = value after reset (x=indeterminate)

Bits 7–0 **SDAT7–SDAT0.** Serial data. Writing to the SPIDAT performs two functions:

- It provides data to be output on the serial output pin if the TALK bit (SPICTL.1 on page 9-21) is set.
- When the SPI is operating as a master, a data transfer is initiated. When initiating a transfer, see the CLOCK POLARITY bit (SPICCR.6 on page 9-18) and the CLOCK PHASE bit (SPICTL.3 on page 9-22) for the requirements.

Writing dummy data to SPIDAT initiates a receiver sequence. Since the data is not hardware justified for characters shorter than eight bits, transmit data must be written in left-justified form, and received data read in right-justified form.

9.3.8 SPI Port Control Register 1 (SPIPC1)

The SPIPC1 controls the SPISTE pin and the SPICLK pin functions.

Figure 9–16. SPI Port Control Register 1 (SPIPC1) — Address 704Dh

7	6	5	4	3	2	1	0
SPISTE data in	SPISTE data out	SPISTE function	SPISTE data dir	SPICLK data in	SPICLK data out	SPICLK function	SPICLK data dir
R-x	RW-0	RW-0	RW-0	R-x	RW-0	RW-0	RW-0

Note: R = read access, W = write access, -n = value after reset (x=indeterminate)

- Bit 7** **SPISTE DATA IN.** SPI slave transmit enable data in flag. This bit contains the current value on the SPISTE pin, regardless of the mode. A write to this bit has no effect.
- Bit 6** **SPISTE DATA OUT.** SPI slave transmit enable data out flag. This bit contains the data to be output on the SPISTE pin (depending on the mode of operation) if the following conditions are met:
- Master mode (SPICTL.2 = 1 — this bit is defined on page 9-21)
 - SPISTE DATA DIR (SPIPC1.4) bit = 1
 - SPISTE FUNCTION (SPIPC1.5) bit = x (indeterminate)
 - Slave mode (SPICTL.2 = 0 — this bit is defined on page 9-21)

Typically, the SPISTE pin in the slave mode acts as an SPI module select (SPIPC1.5 = 1). When this occurs, there is no attempt to write a value out on the SPISTE pin. However, the SPISTE pin can be used as a general-purpose digital I/O pin in the slave mode if the following conditions are met:

 - SPISTE DATA DIR (SPIPC1.4) bit = x (1 = output; 0 = input)
 - SPISTE FUNCTION (SPIPC1.5) bit = 0
- Bit 5** **SPISTE FUNCTION.** SPI slave transmit enable pin function select. This bit selects the function of the SPISTE pin (depending on the mode of operation) if the following conditions are met:
- Master mode (SPICTL.2 = 1 — this bit is defined on page 9-21)
 - The SPISTE FUNCTION bit has no effect on the SPISTE pin in the master mode (the bit is a don't care).
 - The SPISTE pin always functions as a general-purpose I/O pin.
 - Slave mode (SPICTL.2 = 0 — this bit is defined on page 9-21)
 - 0 = SPISTE pin functions as a general-purpose digital I/O pin
 - 1 = SPISTE pin functions as the SPI module select pin

- Bit 4** **SPISTE DATA DIR.** SPI slave transmit enable pin data direction. This bit determines the data direction on the SPISTE pin if the SPISTE FUNCTION bit = 0 or if the SPI is operating in the master mode (SPICTL.1 = 1 — this bit is defined on page 9-21).
- 0 = SPISTE is configured as an input pin.
 - 1 = SPISTE is configured as an output pin.
- Bit 3** **SPICLK DATA IN.** SPICLK pin port data in flag. This bit contains the current value on the SPICLK pin, regardless of the mode. A write to this bit has no effect.
- Bit 2** **SPICLK DATA OUT.** SPICLK pin port data out. This bit contains the data to be output on the SPICLK pin if the following conditions are met:
- SPICLK pin has been defined as a general-purpose digital I/O pin (SPICLK FUNCTION = 0).
 - SPICLK pin data direction has been defined as output (SPICLK DATA DIR = 1).
- Bit 1** **SPICLK FUNCTION.** SPICLK pin function select. This bit defines the function of the SPICLK pin.
- 0 = SPICLK is a general-purpose digital I/O pin.
 - 1 = SPICLK pin contains the SPI clock.
- Bit 0** **SPICLK DATA DIR.** SPICLK data direction. This bit determines the data direction on the SPICLK pin if SPICLK has been defined as a general-purpose digital I/O pin (SPICLK FUNCTION = 0).
- 0 = SPICLK pin is an input pin.
 - 1 = SPICLK pin is an output pin.

9.3.9 SPI Port Control Register 2 (SPIPC2)

The SPIPC2 controls the SPISOMI and SPISIMO pin functions.

Figure 9–17. SPI Port Control Register 2 (SPIPC2) — Address 704Eh

7	6	5	4	3	2	1	0
SPISIMO data in	SPISIMO data out	SPISIMO function	SPISIMO data dir	SPISOMI data in	SPISOMI data out	SPISOMI function	SPISOMI data dir
R-x	RW-0	RW-0	RW-0	R-x	RW-0	RW-0	RW-0

Note: R = read access, W = write access, -n = value after reset (x=indeterminate)

- Bit 7** **SPISIMO DATA IN.** SPISIMO pin data in. This bit contains the current value on the SPISIMO pin, regardless of the mode. A write to this bit has no effect.
- Bit 6** **SPISIMO DATA OUT.** SPISIMO pin data out. This bit contains the data to be output on the SPISIMO pin if both the following conditions are met:
- The SPISIMO pin is defined as a general-purpose digital I/O pin (SPISIMO FUNCTION = 0).
 - The SPISIMO pin data direction is defined as output (SPISIMO DATA DIR = 1).
- Bit 5** **SPISIMO FUNCTION.** SPISIMO pin function select. This bit defines the function of the SPISIMO pin.
- 0 = The SPISIMO pin is a general-purpose digital I/O pin.
 - 1 = The SPISIMO pin contains the SPI data.
- Bit 4** **SPISIMO DATA DIR.** SPISIMO data direction. This bit determines the data direction on the SPISIMO pin if this pin is defined as a general-purpose I/O pin (SPISIMO FUNCTION = 0).
- 0 = The SPISIMO pin is an input pin.
 - 1 = The SPISIMO pin is an output pin.
- Bit 3** **SPISOMI DATA IN.** SPISOMI pin data in. This bit contains the current value on the SPISOMI pin, regardless of the mode. A write to this bit has no effect.
- Bit 2** **SPISOMI DATA OUT.** SPISOMI pin data out. This bit contains the data to be output on the SPISOMI pin if both the following conditions are met:
- The SPISOMI pin has been defined as a general-purpose digital I/O pin (SPISOMI FUNCTION = 0).
 - The SPISOMI pin data direction has been defined as output (SPISOMI DATA DIR = 1).

Bit 1 **SPISOMI FUNCTION.** SPISOMI pin function select. This bit defines the function of the SPISOMI pin. When SPISOMI is an input signal and SPISOMI FUNCTION and SPISOMI DATA DIR are disabled, the SPICLK signal still clocks the internal circuitry.

0 = The SPISOMI pin is a general-purpose digital I/O pin.

1 = The SPISOMI pin contains the SPI data.

Bit 0 **SPISOMI DATA DIR.** SPISOMI data direction. This bit determines the data direction on the SPISOMI pin if this pin is defined as a general-purpose digital I/O pin (SPISOMI FUNCTION = 0).

0 = The SPISOMI pin is an input pin.

1 = The SPISOMI pin is an output pin.

9.3.10 SPI Priority Control Register (SPIPRI)

The SPIPRI selects the interrupt priority level of the SPI interrupt and controls the SPI operation on the XDS emulator during program suspensions.

Figure 9–18. SPI Priority Control Register (SPIPRI) — Address 704Fh

7	6	5	4–0
Reserved	SPI priority	SPI ESPEN	Reserved
	RW–0	RW–0	

Note: R = read access, W = write access, –0 = value after reset

- Bit 7** **Reserved.** Reads are indeterminate, and writes have no effect.
- Bit 6** **SPIPRIORITY.** Interrupt priority select. This bit specifies the priority level of the SPI interrupt.
- 0 = Interrupts are high priority requests.
1 = Interrupts are low priority requests.
- Bit 5** **SPIESPEN.** Emulator suspend enable. This bit has no effect except when you are using the XDS emulator to debug a program. During debugging, this bit determines SPI operation when the program is suspended by an action such as a hardware or software breakpoint.
- 0 = When the emulator is suspended, the SPI continues to work until the current transmit/receive sequence is complete.
1 = When the emulator is suspended, the state of the SPI is frozen so that it can be examined at the point that the emulator was suspended.
- Bits 4–0** **Reserved.** Reads are indeterminate, and writes have no effect.

9.4 SPI Operation-Mode Initialization Examples

Example 9–3. TMS320x240 SPI Slave Mode Code

```

;*****
; File Name   : TMS320x240 SPI Slave Mode Example Code
;
; TMS320x240 SPI example code #2:  4 Pin SPI option
;                                   - SLAVE MODE
;                                   - Interrupts are enabled
;                                   - # bytes of data transmitted - 7h
;                                   - # bytes of data received   - 8h
;
;*****
; SET statements for '24x devices are device dependent.  The SET locations
; used in this example are typically true for devices with only one SPI
; module.  Consult the device data sheet to determine the exact memory map
; locations of the modules you will be accessing (control registers, RAM,
; ROM).
;
;       .include "c240reg.h"           ; contains a list of SET statements
;                                     ; for all registers on TMS320x240.
; The following SET statements for the SPI are contained in c240reg.h
; and are shown explicitly for clarity.
;Serial Peripheral Interface (SPI) Registers
;~~~~~
SPICCR      .set    07040h           ; SPI Configuration Control Register
SPICTL      .set    07041h           ; SPI Operation Control Register
SPISTS      .set    07042h           ; SPI Status Register
SPIBRR      .set    07044h           ; SPI Baud Rate Register
SPIEMU      .set    07046h           ; SPI Emulation Buffer Register
SPIBUF      .set    07047h           ; SPI Serial Input Buffer Register
SPIDAT      .set    07049h           ; SPI Serial Data Register
SPIPC1      .set    0704Dh           ; SPI Port Control Register #1
SPIPC2      .set    0704Eh           ; SPI Port Control Register #2
SPIPRI      .set    0704Fh           ; SPI Priority Register
;-----
; Constant definitions
;-----
LENGTH      .set    08h             ; length of the data stream to be
;                                     ; transmitted/received by SEND_ALL
DECODE      .set    01h             ; Decode value to used to enable slave
;                                     ; transmissions.
;-----
; Variable definitions
;-----
;
; The transmit and receive buffer locations are defined below.
; The actual .bss location will need to be defined in the
; linker control file.
;

```

Example 9–3. TMS320x240 SPI Slave Mode Code (Continued)

```

        .bss DATAOUT,LENGTH          ; Location of LENGTH byte character stream
                                        ; transmitted by the SEND_ALL routine.
        .bss DATAIN,LENGTH          ; Location of LENGTH byte character stream
                                        ; received by the SEND_ALL routine.
;-----
;
; Macro definitions
;-----
KICK_DOG      .macro                  ; Watchdog reset macro
                LDP      #00E0h
                SPLK    #05555h, WD_KEY
                SPLK    #0AAAAh, WD_KEY
                LDP      #0h
                .endm
;=====
; Initialized data for SEND_ALL subroutine
;=====
        .data
TXDATA      .word  0FDh,0FBh,0F7h,0EFh,0DFh,0BFh,07Fh
;=====
; Reset & interrupt vectors
;=====
        .sect      "vectors"
RSVECT      B      START              ; PM 0      Reset Vector      1
INT1        B      INT1_ISR           ; PM 2      Int level 1      4
INT2        B      PHANTOM            ; PM 4      Int level 2      5
INT3        B      PHANTOM            ; PM 6      Int level 3      6
INT4        B      PHANTOM            ; PM 8      Int level 4      7
INT5        B      PHANTOM            ; PM A      Int level 5      8
INT6        B      PHANTOM            ; PM C      Int level 6      9
RESERVED    B      PHANTOM            ; PM E      (Analysis Int) 10
SW_INT8     B      PHANTOM            ; PM 10     User S/W int     -
SW_INT9     B      PHANTOM            ; PM 12     User S/W int     -
SW_INT10    B      PHANTOM            ; PM 14     User S/W int     -
SW_INT11    B      PHANTOM            ; PM 16     User S/W int     -
SW_INT12    B      PHANTOM            ; PM 18     User S/W int     -
SW_INT13    B      PHANTOM            ; PM 1A     User S/W int     -
SW_INT14    B      PHANTOM            ; PM 1C     User S/W int     -
SW_INT15    B      PHANTOM            ; PM 1E     User S/W int     -
SW_INT16    B      PHANTOM            ; PM 20     User S/W int     -
TRAP        B      PHANTOM            ; PM 22     Trap vector      -
NMI         B      PHANTOM            ; PM 24     Non maskable Int 3
EMU_TRAP    B      PHANTOM            ; PM 26     Emulator Trap    2
SW_INT20    B      PHANTOM            ; PM 28     User S/W int     -
SW_INT21    B      PHANTOM            ; PM 2A     User S/W int     -
SW_INT22    B      PHANTOM            ; PM 2C     User S/W int     -
SW_INT23    B      PHANTOM            ; PM 2E     User S/W int     -

```

Example 9–3. TMS320x240 SPI Slave Mode Code (Continued)

```

; Begin the Reset initialization here ...
        .text
START:
        CLRC    SXM                ; Clear Sign Extension Mode
        CLRC    OVM                ; Reset Overflow Mode
* Set Data Page pointer to page 1 of the peripheral frame
        LDP     #DP_PF1            ; Page DP_PF1 includes WET through EINT frames
* initialize WDT registers
        SPLK    #06Fh, WDTCR       ; clear WDFLAG, Disable WDT, set WDT for 1 se-
cond
                                           ; overflow (max)
        SPLK    #07h, RTICR        ; clear RTI Flag, set RTI for 1 second overflow
                                           ; (max)
* configure PLL for 4MHz xtal, 10MHz SYSCLK and 20MHz CPUCLK
        SPLK    #00E4h, CKCR1      ; CLKIN(XTAL)=4MHz, CPUCLK=20MHz
        SPLK    #0043h, CKCR0      ; CLKMD=PLL disable, SYSCLK=CPUCLK/2,
        SPLK    #00C3h, CKCR0      ; CLKMD=PLL Enable, SYSCLK=CPUCLK/2,
* Clear reset flag bits in SYSSR (PORRST, PLLRST, ILLRST, SWRST, WDRST)
        LACL    SYSSR              ; ACCL <= SYSSR
        AND     #00FFh             ; Clear upper 8 bits of SYSSR
        SACL    SYSSR              ; Load new value into SYSSR
* Initialize IOP20/CLKOUT pin for use as DSP clock out
        SPLK    #40C8h, SYSCR       ; No reset, CLKOUT=CPUCLK, VCCA on
* initialize B2 RAM to zero's.
        LAR     AR1, #B2_SADDR      ; AR1 <= B2 start address
        MAR     *, AR1              ; use B2 start address for next indirect
        ZAC                                           ; ACC <= 0
        RPT     #1fh               ; set repeat counter for 1fh+1=20h or 32 loops
        SACL    *+                  ; write zeros to B2 RAM
* initialize DATAOUT with data to be transmitted.
        LAR     AR1, #DATAOUT       ; AR1 <= DATAOUT start address
        RPT     #06h               ; set repeat counter for 6h+1=7h or 7 loops
        BLPD    #TXDATA, *+        ; loads 60h - 67h with TXDATA
* Initialize DSP for interrupts
        LAR     AR6, #IMR           ;
        LAR     AR7, #IFR           ;
        MAR     *, AR6              ;
        LACL    #01h               ;
        SACL    *, AR7              ; Enable interrupts 1 only
        LACL    *                   ; Clear IFR by reading and
        SACL    *, AR2              ; writing contents back into itself
        CALL    INIT_SPI
        CLRC    INTM                ; Enable DSP interrupts
; Main routine goes here.

```

Example 9–3. TMS320x240 SPI Slave Mode Code (Continued)

```

MAIN                                ; Main loop of code begins here
;      ....                          ; insert actual code here
      NOP
      NOP
      NOP
;      ....                          ; insert actual code here
      B      MAIN                    ; The MAIN program loop has completed one
;                                     ; pass, branch back to the beginning and
;                                     ; continue.
*****
*                                     Subroutines                                     *
*****
;=====
; Routine Name:  INIT_SPI              Routine Type:  SR
;
; Description:  This SR initializes the SPI for data stream transfer
;               to a master SPI.  The '240 SPI is configured for
;               8-bit transfers as a slave.
;=====
INIT_SPI:
* initialize SPI in slave mode
  SPLK  #007Fh,SPICCR ; Reset SPI by writing 1 to SWRST
  SPLK  #0008h,SPICTL ; Disable ints & TALK, normal clock, slave mode
  SPLK  #0000h,SPIPRI ; Set SPI interrupt to high priority.
;                                     ; For emulation purposes, allow the SPI
;                                     ; to continue after an XDS suspension.
;                                     ; HAS NO EFFECT ON THE ACTUAL DEVICE.
  SPLK  #000Eh,SPIBRR ; Set baud rate to 'fastest'
; NOTE: The baud rate should be as fast as possible for communications
;       between two or more SPI's.  Issues in the baud rate selection to
;       remember are the master vs. slave maximum speed differences, and
;       to a lesser degree, the clock speed of each device.  For DSP
;       controllers and TI peripheral devices this determined by SYSCLK.

;       A value of '0Eh' in the SPIBRR will insure the fastest available
;       baud rate for the master and slave device (assuming two DSP controller
;       devices with the same SYSCLK are doing the communication).  This is
;       case when the master SPI uses a polling routine to determine when
;       to transmit the next byte.
  SPLK  #0000h,SPISTS ; Clear the SPI interrupt status bits
  SPLK  #0009h,SPICTL ; Disable TALK & RCV int, CLK ph 1, slave mode
  SPLK  #0022h,SPIPC1 ; Enable the SPISTE and SPICLK pin functions.
;                                     ; SPISTE will function as a transmit enable
;                                     ; input for the slave SPI module.
  SPLK  #0022h,SPIPC2 ; Set SIMO & SOMI functions to serial I/O
  SPLK  #0007h,SPICCR ; Release SWRST, clock polarity 0, 8 bits

```

Example 9–3. TMS320x240 SPI Slave Mode Code (Continued)

```

* Initialize Auxilliary Registers for SPI receive ISR
  LAR   AR1,#LENGTH-1 ; load length of data stream into AR1
                        ; and use for transmit/receive loop counter.
  LAR   AR2,#DATAOUT  ; load location of transmit data stream into
                        ; AR2.
  LAR   AR3,#DATAIN   ; load location of receive data stream into
                        ; AR3.
  RET                                ; Return to MAIN routine.
*****
*                               ISR's                               *
*****
;=====
; I S R - INT1 interrupt service routine
;
; Description: This is an implementation of Method 3: ISR for Single Event
;             per Interrupt Level (see interrupt section in System Functions
;             chapter in Vol 1 of the user's guide).
;
;             This ISR performs initial receive of the DECODE byte from the
;             master SPI. This byte is checked to determine if the master
;             is requesting data from this SPI, and if so, sets the TALK bit
;             to enable transmission and writes a byte into SPIDAT
;             from DATAOUT. The number of bytes received is controlled
;             by the constant LENGTH, which is determined prior to
;             assembly.
;             The TALK bit is cleared after LENGTH # of bytes have been
;             received, and the Auxiliary register pointers are reloaded
;             in preparation of the next transfer.
;=====
INT1_ISR                                ; Interrupt 1 Interrupt Service Routine

      MAR   *,AR3                      ; use location of DATAIN for next indirect
      LACL  SPIBUF                      ; ACC <= SPI Buffer Register
      SACL  *+,AR2                      ; store value in B2 @ DATAIN
                        ; use DATAOUT address for next indirect
      XOR   #DECODE                    ; compare received byte to determine if slave SPI
                        ; is selected.

      BCND  SKIP,NEQ
      SPLK  #000Bh,SPICTL ; Enable TALK & RCV int, CLK ph 1, slave mode
SKIP
      LACL  *+,AR1                      ; ACC <= byte to xmit
                        ; Increment AR2 by one to point to next byte
                        ; in data stream.
                        ; use # bytes left to TX for next indirect address
      SACL  SPIDAT                      ; store Xmit byte to SPIDAT and wait for master clock.
      BANZ  SKIP2,AR2                  ; Branch to SKIP2 if AR1 is not zero,
                        ; decrement AR1 by one,
                        ; use DATAOUT address for next address

```

Example 9–3. TMS320x240 SPI Slave Mode Code (Continued)

```

* Re-Initialize Auxilliary Registers for SPI receive ISR
  LAR   AR1,#LENGTH-1 ; load length of data stream into AR1
                        ; and use for transmit/receive loop counter.
  LAR   AR2,#DATAOUT  ; load location of transmit data stream into
                        ; AR2.
  LAR   AR3,#DATAIN   ; load location of receive data stream into
                        ; AR3.
* Disable talk after LENGTH # of transfers.
  SPLK  #0009h,SPICTL; Disable TALK & RCV int, CLK ph 1, slave mode
SKIP2
  CLRC  INTM          ; Enable DSP interrupts
  RET   ; Return from interrupt
;=====
; I S R - PHANTOM
;
; Description:      ISR used to trap spurious interrupts.
;
;=====
PHANTOM
END    B      END      ;
      .end

```

Example 9–4. TMS320x240 SPI Master Mode Code

```

;*****
; File Name   : TMS320x240 SPI Master Mode Example Code
;
; TMS320x240 SPI example code #1:  4 Pin SPI option
;                                   - MASTER MODE
;                                   - Interrupts are polled
;                                   - # bytes of data transmitted - 8h
;                                   - # bytes of data received   - 8h
;
;*****
; SET statements for '24x devices are device dependent.  The SET locations
; used in this example are typically true for devices with only one SPI
; module.  Consult the device data sheet to determine the exact memory map
; locations of the modules you will be accessing (control registers, RAM,
; ROM).
;
        .include "c240reg.h"           ; contains a list of SET statements
;                                   ; for all registers on TMS320x240.
; The following SET statements for the SPI are contained in c240reg.h
; and are shown explicitly for clarity.
;Serial Peripheral Interface (SPI) Registers
;~~~~~
SPICCR      .set    07040h           ; SPI Configuration Control Register
SPICTL      .set    07041h           ; SPI Operation Control Register
SPISTS      .set    07042h           ; SPI Status Register
SPIBRR      .set    07044h           ; SPI Baud Rate Register
SPIEMU      .set    07046h           ; SPI Emulation Buffer Register
SPIBUF      .set    07047h           ; SPI Serial Input Buffer Register
SPIDAT      .set    07049h           ; SPI Serial Data Register
SPIPC1      .set    0704Dh           ; SPI Port Control Register #1
SPIPC2      .set    0704Eh           ; SPI Port Control Register #2
SPIPRI      .set    0704Fh           ; SPI Priority Register
;-----
; Constant definitions
;-----
LENGTH      .set    08h              ; length of the data stream to be
;                                   ; transmitted/received by SEND_ALL
;-----
; Variable definitions
;-----
;-----
; The transmit and receive buffer locations are defined below.
; The actual .bss location will need to be defined in the
; linker control file.
;
        .bss DATAOUT,LENGTH ; Location of LENGTH byte character stream
;                                   ; transmitted by the SEND_ALL routine.
        .bss DATAIN,LENGTH  ; Location of LENGTH byte character stream
;                                   ; received by the SEND_ALL routine.
;-----

```

Example 9–4. TMS320x240 SPI Master Mode Code (Continued)

```

SPI_DONE      .set 070h                ; Defined B2 RAM location '70h' as SPI transmit
                                           ; status location. 1=complete, 0=not complete
;-----
; Macro definitions
;-----
KICK_DOG      .macro                   ; Watchdog reset macro
               LDP      #00E0h
               SPLK    #05555h, WD_KEY
               SPLK    #0AAAAh, WD_KEY
               LDP      #0h
               .endm
;=====
; Initialized data for SEND_ALL subroutine
;=====
               .data
TXDATA        .word      01h,02h,04h,08h,10h,20h,40h,80h
;=====
; Reset & interrupt vectors
;=====
               .sect  "vectors"
RSVECT        B          START          ; PM 0          Reset Vector          1
INT1          B          PHANTOM        ; PM 2          Int level 1          4
INT2          B          PHANTOM        ; PM 4          Int level 2          5
INT3          B          PHANTOM        ; PM 6          Int level 3          6
INT4          B          PHANTOM        ; PM 8          Int level 4          7
INT5          B          PHANTOM        ; PM A          Int level 5          8
INT6          B          PHANTOM        ; PM C          Int level 6          9
RESERVED      B          PHANTOM        ; PM E          (Analysis Int)     10
SW_INT8       B          PHANTOM        ; PM 10         User S/W int        -
SW_INT9       B          PHANTOM        ; PM 12         User S/W int        -
SW_INT10      B          PHANTOM        ; PM 14         User S/W int        -
SW_INT11      B          PHANTOM        ; PM 16         User S/W int        -
SW_INT12      B          PHANTOM        ; PM 18         User S/W int        -
SW_INT13      B          PHANTOM        ; PM 1A         User S/W int        -
SW_INT14      B          PHANTOM        ; PM 1C         User S/W int        -
SW_INT15      B          PHANTOM        ; PM 1E         User S/W int        -
SW_INT16      B          PHANTOM        ; PM 20         User S/W int        -
TRAP          B          PHANTOM        ; PM 22         Trap vector         -
NMI           B          PHANTOM        ; PM 24         Non maskable Int    3
EMU_TRAP      B          PHANTOM        ; PM 26         Emulator Trap       2
SW_INT20      B          PHANTOM        ; PM 28         User S/W int        -
SW_INT21      B          PHANTOM        ; PM 2A         User S/W int        -
SW_INT22      B          PHANTOM        ; PM 2C         User S/W int        -
SW_INT23      B          PHANTOM        ; PM 2E         User S/W int        -
; Begin the Reset initialization here ...
               .text
START:
               CLRC    SXM              ; Clear Sign Extension Mode
               CLRC    OVM              ; Reset Overflow Mode
* Set Data Page pointer to page 1 of the peripheral frame
               LDP      #DP_Pf1        ; Page DP_Pf1 includes WET through EINT frames

```

Example 9-4. TMS320x240 SPI Master Mode Code (Continued)

```

* initialize WDT registers
    SPLK    #06Fh, WDTCR ; clear WDFLAG, Disable WDT, set WDT for 1 second
                ; overflow (max)
    SPLK    #07h, RTICR ; clear RTI Flag, set RTI for 1 second overflow (max)
* configure PLL for 4MHz xtal, 10MHz SYSCLK and 20MHz CPUCLK
    SPLK    #00E4h,CKCR1 ; CLKIN(XTAL)=4MHz,CPUCLK=20MHz
    SPLK    #0043h,CKCR0 ; CLKMD=PLL disable,SYSCLK=CPUCLK/2,
    SPLK    #00C3h,CKCR0 ; CLKMD=PLL Enable,SYSCLK=CPUCLK/2,
* Clear reset flag bits in SYSSR (PORRST, PLLRST, ILLRST, SWRST, WDRST)
    LACL    SYSSR      ; ACCL <= SYSSR
    AND     #00FFh     ; Clear upper 8 bits of SYSSR
    SACL    SYSSR      ; Load new value into SYSSR
* Initialize IOP20/CLKOUT pin for use as DSP clock out
    SPLK    #40C8h,SYSCR ; No reset, CLKOUT=CPUCLK, VCCA on
* initialize B2 RAM to zero's.
    LAR     AR1,#B2_SADDR; AR1 <= B2 start address
    MAR     *,AR1      ; use B2 start address for next indirect
    ZAC     ; ACC <= 0
    RPT     #1fh      ; set repeat counter for 1fh+1=20h or 32 loops
    SACL    *+        ; write zeros to B2 RAM
* initialize DATAOUT with data to be transmitted.
    LAR     AR1,#DATAOUT ; AR1 <= DATAOUT start address
    RPT     #07h      ; set repeat counter for 7h+1=8h or 8 loops
    BLPD    #TXDATA,*+ ; loads 60h - 68h with 01, 02, 04, ... , 40, 80h
    CALL    INIT_SPI

; Main routine goes here. Whenever the data stream previously loaded
; into the DATAOUT location is desired to be transmitted,
; the SEND_ALL subroutine is called.
MAIN
;         .... ; insert actual code here
    CALL  SEND_ALL ; Call the SEND_ALL subroutine and when it is
                ; finished, continue with the MAIN loop.
;         .... ; insert actual code here
    B     MAIN    ; The MAIN program loop has completed one
                ; pass, branch back to the beginning and
                ; continue.

*****
*           Subroutines                                     *
*****
;=====
; Routine Name: INIT_SPI           Routine Type: SR
;
; Description: This SR initializes the SPI for data stream transfer
;              to a slave SPI. The '240 SPI is configured for
;              8-bit transfers as a master.
;=====

```

Example 9-4. TMS320x240 SPI Master Mode Code (Continued)

```

INIT_SPI:
* initialize SPI in master mode
    SPLK    #0087h,SPICCR        ; Reset SPI by writing 1 to SWRST
    SPLK    #000Ch,SPICTL       ; Disable ints & TALK, normal clock, master
mode
    SPLK    #0000h,SPIPRI       ; Set SPI interrupt to high priority.
                                ; For emulation purposes, allow the SPI
                                ; to continue after an XDS suspension.
                                ; HAS NO EFFECT ON THE ACTUAL DEVICE.
    SPLK    #000Eh,SPIBRR       ; Set baud rate to 'fastest'
; NOTE: The baud rate should be as fast as possible for communications
;       between two or more SPI's.  Issues in the baud rate selection to
;       remember are the master vs. slave maximum speed differences, and
;       to a lesser degree, the clock speed of each device.  For DSP
;       controllers and TI peripherals devices this determined by SYSCLK .
;
;       A value of '0Eh' in the SPIBRR will insure the fastest available
;       baud rate for the master and slave device (assuming two DSP controller
;       devices with the same SYSCLK are doing the communication).  This
;       is true for the case when the master SPI uses a polling routine to
;       determine when to transmit the next byte.
    SPLK    #0000h,SPISTS       ; Clear the SPI interrupt status bits
    SPLK    #000Eh,SPICTL       ; Enable TALK, CLK ph 1, master mode
    SPLK    #0052h,SPIPC1       ; Enable the SPICLK pin function.
                                ; SPISTE will always be general I/O when
                                ; SPI is in master mode, regardless of
                                ; function bit state.  Set SPISTE as output
                                ; high - disable receiver SPI output.
    SPLK    #0022h,SPIPC2       ; Set SIMO & SOMI functions to serial I/O
    SPLK    #0007h,SPICCR       ; Release SWRST, clock polarity 0, 8 bits
    RET                                ; Return to MAIN routine.
;=====
; Routine Name: SEND_ALL          Routine Type: SR
;
; Description: This SR performs the data stream transfer.  Data to be
; transmitted is located at DATAOUT.  Received Data is stored
; at DATAIN.  This routine polls the SPI INT FLAG bit,
; SPISTS.6, to determine when each byte transfer has
; completed.  The number of bytes transfered is controlled
; by the constant LENGTH, which is determined prior to
; assembly.
;=====
SEND_ALL:
    LAR     AR1,#LENGTH-1       ; load length of data stream into AR1
                                ; and use for transmit/receive loop counter.
    LAR     AR2,#DATAOUT        ; load location of transmit data stream into
                                ; AR2.
    LAR     AR3,#DATAIN         ; load location of receive data stream into
                                ; AR3.
    MAR     *,AR2               ; use DATAOUT for next indirect address

```

Example 9–4. TMS320x240 SPI Master Mode Code (Continued)

```

; Perform a read-modify-write on SPIPC1 to set SPISTE pin active low
; and enable the slave SPI.
    LACL    SPIPC1          ; load contents of SPIPC1 into ACC.
    AND     #0BFh          ; clear SPIPC1.6 to make SPISTE pin active
                          ; low.
    SACL    SPIPC1          ; store ACC out to SPIPC1.
LOOP
; Begin Xmit by writing byte to SPIDAT.
    LACL    *,AR3           ; ACC <= byte to xmit
                          ; Increment AR2 by one to point to next byte
                          ; in data stream.
                          ; use DATAIN for next indirect address
    SACL    SPIDAT         ; Xmit byte
POLL  LACL    SPISTS        ; Poll the INT Flag Bit to determine when
                          ; to begin next xmit
    AND     #040h          ; Clear all bits except SPI INT FLAG bit
    XOR     #040h          ; ACC=0 if bit is set
    BCND   POLL,NEQ        ; continue polling if ACC != 0.
    LACL    SPIBUF         ; load the received byte into ACC.
    SACL    *,AR1          ; save the received byte to DATAIN
                          ; increment AR3 by one point to next
                          ; DATAIN location.
                          ; use AR1, # bytes left to tranfer,
                          ; for next indirect address.
    BANZ   LOOP,AR2        ; Branch to LOOP if AR1 is not zero,
                          ; decrement AR1 by one,
                          ; use DATAOUT address for next address
; Optional code section: This code loads a value into B2 RAM to
;                          inform the MAIN routine that the data
;                          stream transfer is complete.
    LAR     AR4,#SPI_DONE   ; load address of SPI status location
                          ; into AR4
    MAR     *,AR4           ; use SPI status location for next indirect
    SPLK    #01h,*         ; write '01h' into status location to indicate
                          ; data stream transfer is complete.
; Perform a read-modify-write on SPIPC1 to set SPISTE pin active high
; and disable the slave SPI.
    LACL    SPIPC1          ; load contents of SPIPC1 into ACC.
    OR     #040h          ; set SPIPC1.6 to make SPISTE pin active
                          ; high.
    SACL    SPIPC1          ; store ACC out to SPIPC1.
    RET                                ; Return to MAIN routine.

```

Example 9–4. TMS320x240 SPI Master Mode Code (Continued)

```
*****
*                               ISR's                               *
*****
;=====
; I S R - PHANTOM
;
; Description:      ISR used to trap spurious interrupts.
;=====
PHANTOM
END      B      END      ;
        .end
```

Flash Memory Module

This chapter describes the flash EEPROM module, generally referred to as the *flash module*, or simply, *flash*. The term *flash array* refers to the actual memory array within the flash module.

For additional information about programming and erasing the flash array, refer to *TMS320F20x/F24x DSP Embedded Flash Memory Technical Reference* (Literature number SPRU282).

Topic	Page
10.1 Flash EEPROM Overview	10-2
10.2 Fundamental Concepts	10-3
10.3 Flash Registers	10-7

10.1 Flash EEPROM Overview

The flash EEPROM module provides an attractive alternative to masked ROM program memory. Like ROM, flash EEPROM is also a nonvolatile memory type; however, it has the advantage of *in-target* reprogrammability, both on the production floor and in the field.

In an actual '240 device-specific implementation, more than one block may be utilized to give a larger overall flash memory capacity. For specific '240 device details, see Chapter 2. The following are available features and options for a single block module of flash:

- Organization: 16K
- Word ($\times 16$ bits) implementation
- Low-power mode
- Access rate supports 50 ns CPU machine cycles with no wait states
- Write/erase performed by DSP core

The flash EEPROM module can contain $16K \times 16$ bits of electrically erasable, electrically programmable read-only memory. It may be used to replace masked ROM or single-access RAM (SARAM) and may be mapped to either program or data space but not both simultaneously. The block size determines the resolution of the start address boundary.

The flash module is erased and programmed by the DSP core itself. This allows the application code to manage the use of the flash memory without the requirement of external programming equipment. The initial programming of the flash may be done using the XDS510 scan-based emulator by scanning in the erase/program algorithm and data into on-chip RAM.

The flash module interfaces to the regular DSP memory interface. This allows the design to take advantage of performance gains provided by the Harvard architecture of the '240 DSP core.

The flash module includes both the flash array and the necessary control registers to erase and program the array.

10.2 Fundamental Concepts

Erasing the flash bits is accomplished by adjusting the charge on all the array (or segment) bits to a level so that they are read as ones. Writing the bits is accomplished by adjusting the charge on individual bits to a level so that they are read as zeros. Figure 10–1 shows this mechanism. Although the write operation adds charge, the written bit is read as zero. The erase operation removes charge from the bits, thus the orientation of the arrows.

Figure 10–1. Flash Bit Programming

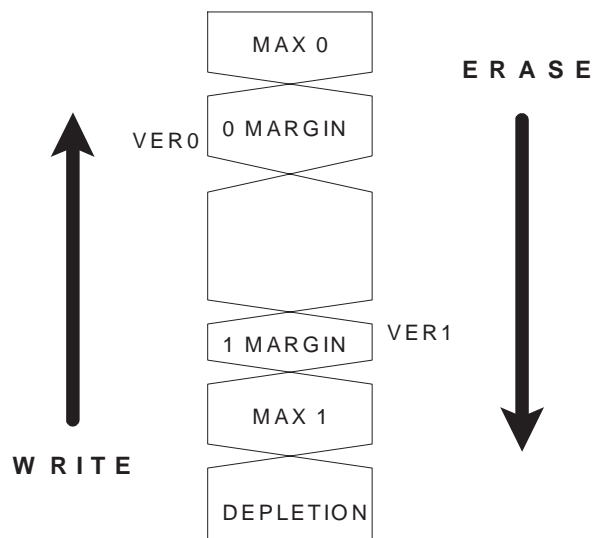

Erasing is a block operation. It simultaneously moves all the bits within the selected segments of an array. Erasure is complete when all bits are erased to a point where the application can consistently read them as ones (1 MARGIN in Figure 10–1). Due to minor process variations across the array, bits do not erase at the same rate. Occasionally, a fast erasing bit may erase beyond the valid threshold into depletion at the same time other bits reach the valid read margin. These bits may be returned to the 1 MARGIN range using the flash-write operation.

The flash bits are addressed on word boundaries with respect to the write operation to allow various word patterns to be loaded into the flash. Although all 16 bits are addressed on a flash word boundary, only 8 bits may be written to at a time due to current limitations in the flash pump. The algorithm limits the write to 8 bits by masking the word to be written into the array.

The programming algorithms use leveling techniques to provide a balanced erasure and writing of the array bits. This balance provides a measured margin for the coded bit patterns programmed within a minimum time. It also matches the device production test programming levels to the application programming levels. The leveling mechanism provides special array read modes (VER1 and VER0) to verify that bits are erased/written to a level beyond what is necessary to meet the specified operational voltage range of the device. The extent beyond the operation level assures data retention for the life of the application and is tested in production test flow of each device.

The leveling technique steps the erase or write operations in increments to align closer to the margins applied. Due to process variances, some bits are programmed faster than others. All bits must be programmed to the specified margins. These smaller incremental steps are used instead of a single larger step to align closer to the applied margins on a bit-by-bit basis. This better alignment to the margin has the primary effect of taking less time to erase and write, and the secondary effect of reducing the time for the opposing write and erase operations. This incremental method aligns well to DSP devices with embedded flash memory, where an embedded DSP core is capable of managing the adaptive algorithm. It would be more costly in a discrete flash module due to the added complexity of the programming state machine.

The array, in a coded state, includes an assortment of ones and zeros of the coded patterns. The clearing step levels the array to all zeros before erasing. This is necessary so that the erase operation processes the bits evenly. If the array is not cleared prior to erasure, 1 bits will be erased further than 0 bits. This makes it more difficult to erase programmed bits to an adequate margin without pushing already erased bits into depletion. Although it may be possible to erase the array without the clear step, it is likely to take much longer due to the flash-write operation necessary to remove the over-erased bits from depletion. The program step also takes longer to re-program the deeper erased bits, conflicting with the minimization of the programming time. It is also possible to reduce the erasure margin, but this conflicts the reliability criteria.

The boost step maintains the 0 margin in conjunction with segment and partial programming operations (when part of an array is coded). When other segments of the array are being erased and recoded, it slightly stresses bits in protected segments. The program margins on protected segments may be reduced after numerous clear, erase, and code operations on other, unprotected segments. In this case, the programming algorithm should include the boost operation to assure that the margins in the already coded areas remain robust. The boost operation should be executed any time part of the array is written.

10.2.1 Erasing

The basic flow of the erase algorithm involves the following key steps:

- 1) Erasing the array to the VER1 margin
- 2) Inverse-erase verification to identify bits clearly in depletion
- 3) Flash-write pulses to recover depletion bits
- 4) Additional flash-write pulse to adjust bits near depletion

Erasing the flash array (step 1) employs a leveling technique discussed in Section 10.2, *Fundamental Concepts*. The special margin read mode, used in erasure, is called VER1. VER1 verifies that the erased array reads ones at a much lower voltage than the V_{CC} specification of the device (approximately 3.5V). The effective minimum for the erase pulse is 5ms due to the flash-pump operation. In previous revisions of the flash module, a longer pulse produced quicker erasures by limiting the overhead associated with the generation of the erase pulse to lower pulse counts. However, characterization of the current revision of the array indicates the minimum erase pulse of 5ms provides the best balance for erasure.

The inverse-erase verification test (step 2) identifies bits that are erased into depletion. This test identifies depletion bits on bit-line boundaries instead of individual bits. This carries the advantage of checking the full array for depletion bits by checking only 32 words of the first row. The inverse-erase test is executed after the array is successfully erased and passes VER1 to minimize overhead associated with the margin test. If the inverse-erase test indicates a depletion bit, then the algorithm recovers the bit using an additional flash-write pulse (step 4) to adjust bits near depletion. If the inverse-erase test passes, flash-write (step 3) is unnecessary, and therefore, skipped.

It is difficult (and sometimes impossible) to write a zero to a bit that has been erased into depletion. In many flash devices, depletion indicates a device failure. However, this array employs a flash-write (step 3) to recover bits that have been erased into depletion. The flash-write feature recovers depleted bits without adversely affecting other erased bits. Flash-write, like erase, operates on all unprotected segments and therefore recovers all depleted bits. The flash-write operation also employs shorter incremental steps to recover, instead of single long steps. Excessive numbers of flash-write pulses stress the word line of the flash row. For this reason, the number of flash-writes is limited to align to the word line stress exercised in device test.

As previously discussed, the inverse-erase test operates on bit lines. These bit lines cross segment boundaries so the inverse-erase test does not identify

the segment where the depletion bit resides. This is an issue because the inverse-erase test is affected by temperature and V_{DD} level; and therefore, it is possible that a bit that passed inverse-erase in the full array erase might fail later in a different environment. For this reason, the algorithm adds one flash-write operation (step 2) between erasing to VER1 margin and inverse erase to push bits that are close to depletion far enough away to avoid the environment changes issue. Another way to address this issue is to flash-write the complete array when inverse-erase indicates a depleted bit in segment erase operations. As long as the above discussed flash-write limit is in place, either method (or both) may be used.

10.2.2 Writing

Bits are written in each of the clear, code, and boost steps. This write operation is the same for each of these steps. The difference between these steps involves the source of the data to be programmed, which does not affect the algorithm used in the writing.

To minimize application costs, the embedded flash modules include charge pumps to provide the higher voltages required for write operations so that the device may operate with a 5V supply. To minimize the cost of the device, these charge pumps are designed to provide enough current to program up to 8 bits at a time. Design pumps capable of programming more bits at a time can be designed, however, they would be significantly larger and more costly.

The bit writing method uses a margin read to provide robust writing of the bits. It reads the bits at a voltage greater than what is specified for the application to assure adequate margin for the life of the application. The array design provides a special read mode (VER0) that changes the voltage at the array cell to approximately 6.5V. After a word has been written, it is read back in VER0 mode to assure that the programming level still reads a zero beyond the V_{DD} maximum. Any bits that do not meet this margin are written again. However, bits that do meet the VER0 read are masked on the second write to assure balanced programming.

As previously noted, the use of incremental, smaller steps, instead of one large step, for writing the bits better aligns to the margin. The write pulse used is set to 100 μ s based upon characterization over all existing revisions of the flash module. The benefit derived from a shorter write pulse is a cost reduction in application manufacture due to reduced programming time.

10.3 Flash Registers

The flash module includes four registers used to control erasing, programming, and testing of the flash array. The DSP core accesses these registers over the same buses as it accesses the flash array. The access to the flash registers (known as register access mode) is enabled by activating an OUT command. The OUT FF0Fh instruction makes the flash registers accessible for reads and/or writes. After executing OUT FF0Fh, the registers are accessed in the memory space decoded for the flash module, and the flash array cannot be accessed. The four registers are repeated every four address locations within the flash modules decoded range. After completing all the necessary reads and/or writes to the control registers, an IN FF0Fh instruction is executed to place the flash array back in array access mode. After executing IN FF0Fh, the flash array is accessed in the decoded space, and the flash registers are not available. The four registers are described in Table 10–1.

Table 10–1. Addresses of Flash EEPROM Module Registers

Address	Register	Name	Description	Described in	
				Subsection	Page
0	SEG_CTR	Flash Segment Control Register	The 8 MSBs enable specific segments	10.3.1	10-7
1	TST	Flash Test Register	Reserved for test and is not accessible during normal operational modes	10.3.2	10-10
2	WADRS	Write Address Register	Holds the address for a write operation	10.3.3	10-10
3	WDATA	Write Data Register	Holds the data for a write operation	10.3.4	10-10

10.3.1 Flash Segment Control Register (SEG_CTR)

The SEG_CTR is a 16-bit register used to initiate and monitor the programming and erasing of the flash array. This register includes the signals necessary to initiate the active operations (WRITE, ERASE, and EXE), those used for verification (VER0 and VER1), and those used for protection (KEY0, KEY1, and SEG7–SEG0). The reset signal clears all bits of SEG_CTR to 0.

The WRITE signal initiates the programming operation. However, the modification of the flash EEPROM array data does not actually actively start until the EXE is activated and the KILL_EXE signals is deactivated. The WRITE, KEY1, and appropriate SEG0–7 signals must be set high while all other signals set low for the programming operation to begin.

The ERASE operation is done in a similar manner except that the ERASE signal is high and the WRITE signal is low. The FLASH–WRITE operate requires both the WRITE and ERASE signals be active high.

Once the EXE bit is active, all register bits, other than the control bits are latched and protected. The user must deactivate the EXE bits to modify the SEG7–0 bits. This protects the array from an inadvertent change of the protected segments. However, it also means the unprotected segments cannot be masked in the same register load with the deactivation of EXE.

The SEG_CTR is shown in Figure 10–2 and descriptions of the bits follow the figure.

Figure 10–2. Segment Control Register (SEG_CTR)

15	14	13	12	11	10	9	8	7	6	5	4	3	2–1	0
SEG7	SEG6	SEG5	SEG4	SEG3	SEG2	SEG1	SEG0	Res	KEY1	KEY0	VER0	VER1	Write/ erase	EXE
RW–0	RW–0	RW–0	RW–0	RW–0	RW–0	RW–0	RW–0		RW–0	RW–0	RW–0	RW–0	RW–0	RW–0

Note: R = Read, W = Write, –0 = value after reset

Bits 15–8[†] SEG7–SEG0. Flash segment enable bits. Each segment enable bit is used to protect or enable write and erase operations for each of the segments in the flash array.

Bit 7 Reserved.

Bits 6–5 KEY1, KEY0. Execute key bits. These bits must be written as 1 0 in the same DSP core access as the EXE bit is set for the EXE operation to start. These bits are used as additional protection against inadvertent programming or erasure of the flash. These bits are read as zeros.

[†]Segment Protection

Although these segment control bits exist, you should not use segment control to the flash arrays in TMS320F24x devices. Segment protection is not recommended for these devices.

Bits 4–3 **VER0, VER1.** Verify bits. The DSP core verifies proper erasure and programming by monitoring these bits. The 1s verify test is used to verify that the array is sufficiently erased. This operation mode lowers the voltage on the cell gate during the read. If the bits still read as 1, the erasure provides sufficient margin for reliable read and program operations. The 0s verify test is used to verify that a given bit has been sufficiently programmed. This operation mode raises the voltage at the cell gate. If the bits still read as 0, the programming provides sufficient margin for reliable read operations. Possible modes for bits 4 and 3:

0 0 = Normal read

0 1 = Read using low-sense voltage to verify margin of 1s

1 0 = Read using high-sense voltage to verify margin of 0s

1 1 = Inverse-erase mode; tests for bits erased to depletion

Bits 2–1 **WRITE/ERASE.** Possible modes for bits 2 and 1:

0 0 = Undefined

0 1 = ERASE

1 0 = WRITE

1 1 = FLASH-WRITE

Bit 0 **EXE.** Execute bit. This bit starts and stops programming and erasing to the flash array. The EXE bit and the KEY0/1 bits must be written in the same write access. When the programming time has expired, the EXE bit should be cleared in the same write as the KEY0/1 bits. The data and address latches are locked whenever the EXE bit is set and all attempts to read from, or write to, the array will be ignored (read data will be indeterminate).

10.3.2 Flash Test Register (TST)

The flash test register (TST) is a 5-bit register used for testing the flash array. The details of the test operations do not pertain to the customer responsibilities for DSP design and test, and therefore, are not discussed. This register is not accessible to the DSP core unless the DSP core is in test mode.

10.3.3 Write Address Register (WADRS)

The write address register (WADRS) is a 16-bit register that contains the latched write address for a programming operation. This register is loaded with the value on the address bus when writing a data value to the flash module when in array access mode. It may also be loaded by writing to this register when in register access mode.

10.3.4 Write Data Register (WDATA)

The write address register (WDATA) is a 16-bit register that contains the latched write data for a programming operation. This register may be loaded by writing a data value to the flash module when in array access mode, or by writing to this register when in register access mode. The WDATA must be loaded with the value FFFFh before the erase operation starts. If this register is not loaded with this value, the erase operation will not begin.

External Memory Interface

This chapter provides a general description of the external memory interface; the interface between the CPU and parts of external memory such as program memory, local data memory, and I/O space.

Topic	Page
11.1 External Interface to Program Memory	11-2
11.2 External Interface to Local Data Memory	11-5
11.3 Interface to I/O Space	11-8
11.4 Memory Interface Timing Diagrams	11-10
11.5 Wait-State Generator	11-12

11.1 External Interface to Program Memory

The 'C240 can address up to 64K words of program memory. While the 'C240 accesses the on-chip program memory blocks, the external memory signals \overline{PS} and \overline{STRB} are inactive high. The external data and address bus is active only when the 'C240 is accessing locations within the address ranges that are mapped to external memory locations. Table 11–1 lists the key signals for external memory interfacing.

Table 11–1. Key Signals for External Interfacing to Program Memory

Signal	Description
A15–A0	16-bit bidirectional address bus
BR	Bus request
D15–D0	16-bit bidirectional data bus
\overline{PS}	Program memory select
READY	Memory ready to complete cycle
R/\overline{W}	Read-not-write signal
\overline{STRB}	External memory access active strobe
\overline{WE}	Write-enable signal
W/\overline{R}	Write-not-read signal

Figure 11–1 on page 11-3 shows an example of a minimal external program memory interface. In Figure 11–1, the 'C240 device interfaces to two 16K × 8-bit SRAMs. Two 8-bit wide memories are used to implement the 16-bit word width required by the 'C240. Although SRAMs are shown in Figure 11–1, the interface is equally valid for EPROMs, with the removal of the write enable (\overline{WE}) signal.

The interface shown in Figure 11–1 assumes a zero wait-state read/write cycle; that is, the memory access time has been appropriately chosen. See the 'C240 data sheet for the exact bus timing parameters.

If slower memory is used, the on-chip wait-state generator can be used to insert one wait state to the access cycle. If more than one wait state is needed, external wait-state logic is required since it uses the READY signal to extend the bus cycle by the required number of wait states.

Figure 11–1. Interface to External Program Memory

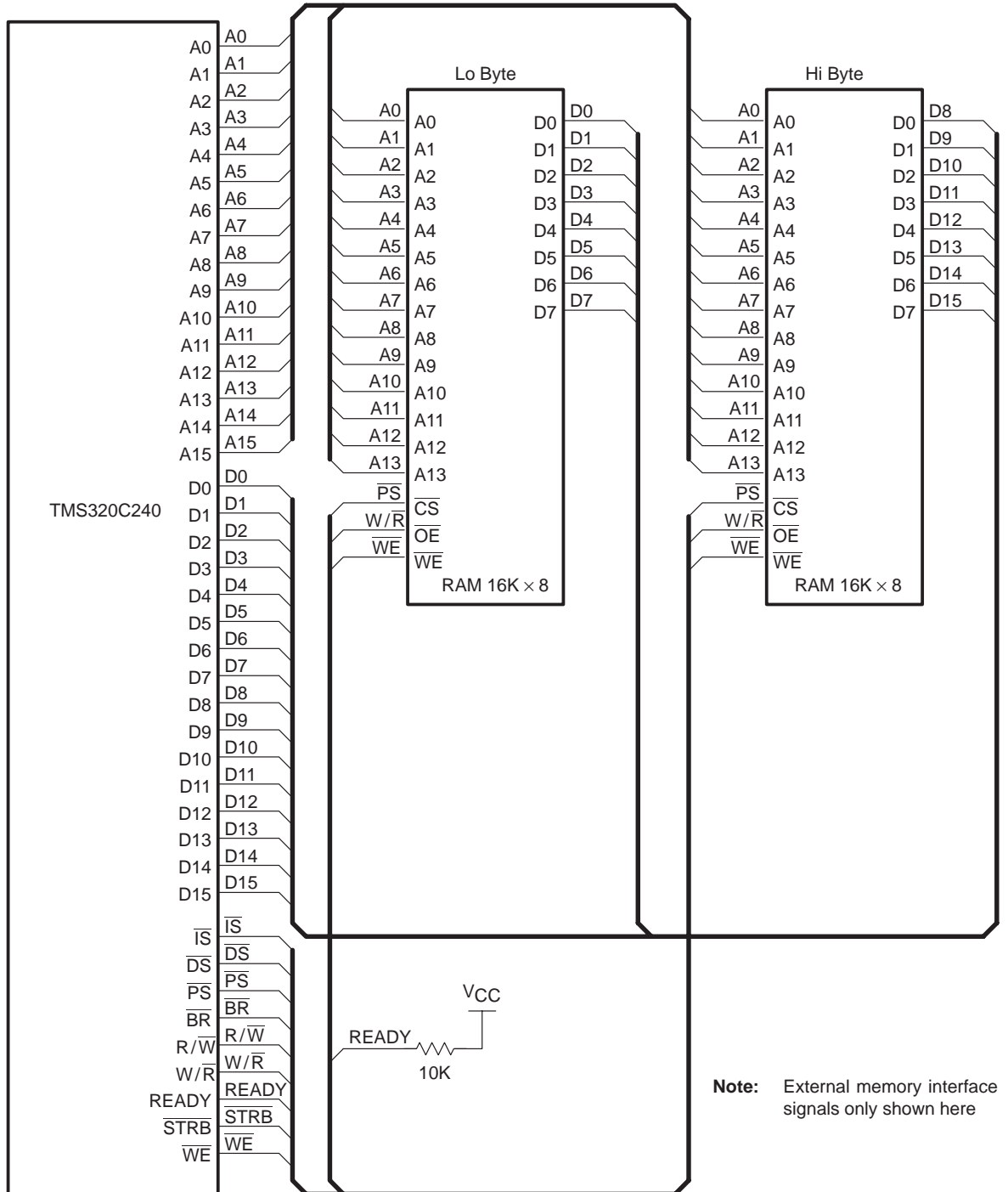

Note: External memory interface signals only shown here

The program select (\overline{PS}) signal is connected directly to the chip select (\overline{CS}) to select the memory on any external program access. The memory is addressed in any 16K address block in program space. If multiple blocks of memory are to be interfaced in program space, a decode circuit that gates \overline{PS} and the appropriate address bits can be used to drive the memory block chip selects.

The W/\overline{R} signal is tied directly to the output enable (\overline{OE}) pin of the memory. The \overline{OE} signal enables the output drivers of the memory. The drivers are turned off in time to guarantee that no data bus conflicts occur with an external write by the 'C240 device.

The 'C240 requires two cycles on all external writes, including a half cycle before the \overline{WE} goes low and a half cycle after \overline{WE} goes high. This prevents buffer conflicts on the external busses.

11.2 External Interface to Local Data Memory

The 'C240 device can address up to 32K words of off-chip local data memory. Table 11–2 lists the key signals necessary for this interface.

Table 11–2. Key Signals for External Interfacing to Local Data Memory

Signal	Description
A15–A0	16-bit bidirectional address bus
BR	Bus request
D15–D0	16-bit bidirectional data bus
\overline{DS}	Data memory select
READY	Memory ready to complete cycle
R/\overline{W}	Read-not-write signal
\overline{STRB}	External memory access active strobe
\overline{WE}	Write-enable signal
W/\overline{R}	Write-not-read signal

While the 'C240 accesses the on-chip data memory blocks, the external signals \overline{DS} and \overline{STRB} are inactive high. The external data bus is active only when the 'C240 is accessing locations within the address ranges that are mapped to external memory, 8000h–FFFFh. An active \overline{DS} signal indicates that the external busses are being used for data memory. Whenever the external busses are active (when the external memory is being accessed), the 'C240 drives the \overline{STRB} signal low.

For fast interfacing, it is important to select external memory with fast access time. If fast memory access is not required, you can use the READY signal and/or on-chip wait-state generator to create wait states for interfacing with slow external memory devices.

Figure 11–2 shows an example of an external RAM interface. In this figure, the 'C240 device interfaces two 16K × 8-bit RAM devices. The data memory select (\overline{DS}) is directly connected to the chip select (\overline{CS}) of the devices. This means the external RAM block will be addressed in any of the two 16K banks of local data space, 8000h–FFFFh. If there are additional banks of off-chip data memory, a decode circuit that gates \overline{DS} with the appropriate address bits can be used to drive the memory block chip set.

The $\overline{W/R}$ signal is tied directly to the output enable (\overline{OE}) pin of the RAMs. This signal enables the output drivers of the RAM and turns them off in time to prevent data bus conflicts with an external write by the 'C240. The \overline{WE} signal of RAM is connected to the \overline{WE} signal of 'C240. The 'C240 requires at least two cycles on external writes, including a half cycle before \overline{WE} goes low and a half cycle after \overline{WE} goes high. This prevents buffer conflicts on the external buses. An additional wait state can be generated with the software wait-state generator.

Figure 11–2. Interface to External Data Memory

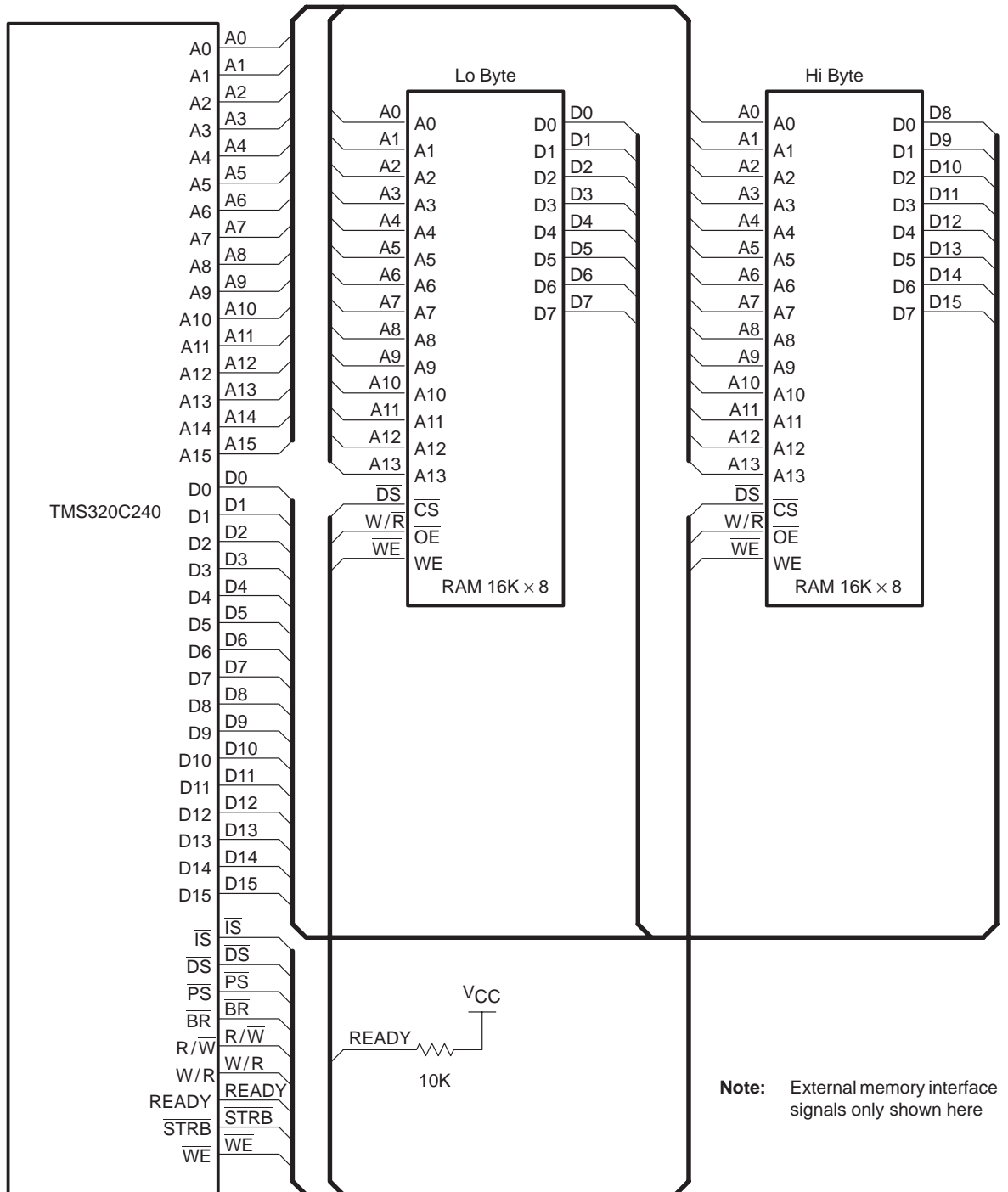

Note: External memory interface signals only shown here

11.3 Interface to I/O Space

I/O space accesses are distinguished from program and data-memory accesses by \overline{IS} going low. All 64K I/O words (external I/O ports and on-chip I/O registers) are accessed via the IN and OUT instructions. See Example 11–1 and Example 11–2.

Example 11–1. External I/O Port Access

```
IN DAT7, 0AFEEh ; Read data into data memory from external
                ; device on port 45038.
OUTDAT7, 0CFEFh ; Write data from data memory to external
                ; device on port 53231.
```

Example 11–2. I/O-Mapped Register Access

```
IN DAT7, FFFFh ; Read data into data memory from 'C240 to
                ; wait state generator control register
OUTDAT8, FFFFh ; Write data from data memory to 'C240
                ; wait state generator control register
```

Access to external parallel I/O ports is multiplexed over the same address and data bus for program and data memory accesses. The data bus is 16 bits wide; however, if you are using 8-bit peripherals, you can use either the higher or the lower byte of the data bus to suit a particular application.

W/\overline{R} can be used with chip-select logic to generate an output enable signal for an external peripheral. The \overline{WE} signal can be used with chip-select logic to generate a write enable signal for an external peripheral. Figure 11–3 shows an example of interface circuitry for 16 I/O ports. Note that the decode section can be simplified if fewer I/O ports are used.

11.4 Memory Interface Timing Diagrams

Figure 11–4 shows the memory interface read waveforms and Figure 11–5 shows the memory interface write waveforms. Both figures are for demonstration purposes only. For accurate timing parameters, see the 'C240 data sheet.

Figure 11–4. Memory Interface Read Waveforms

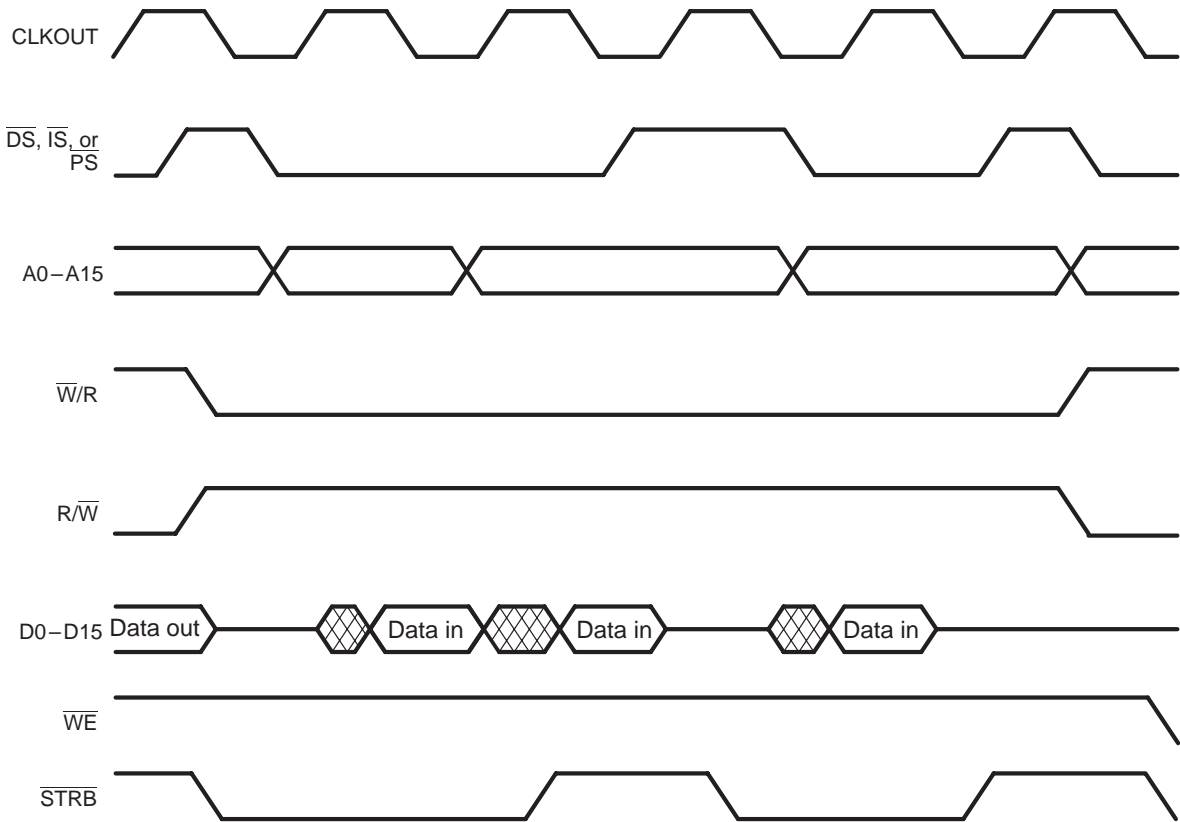
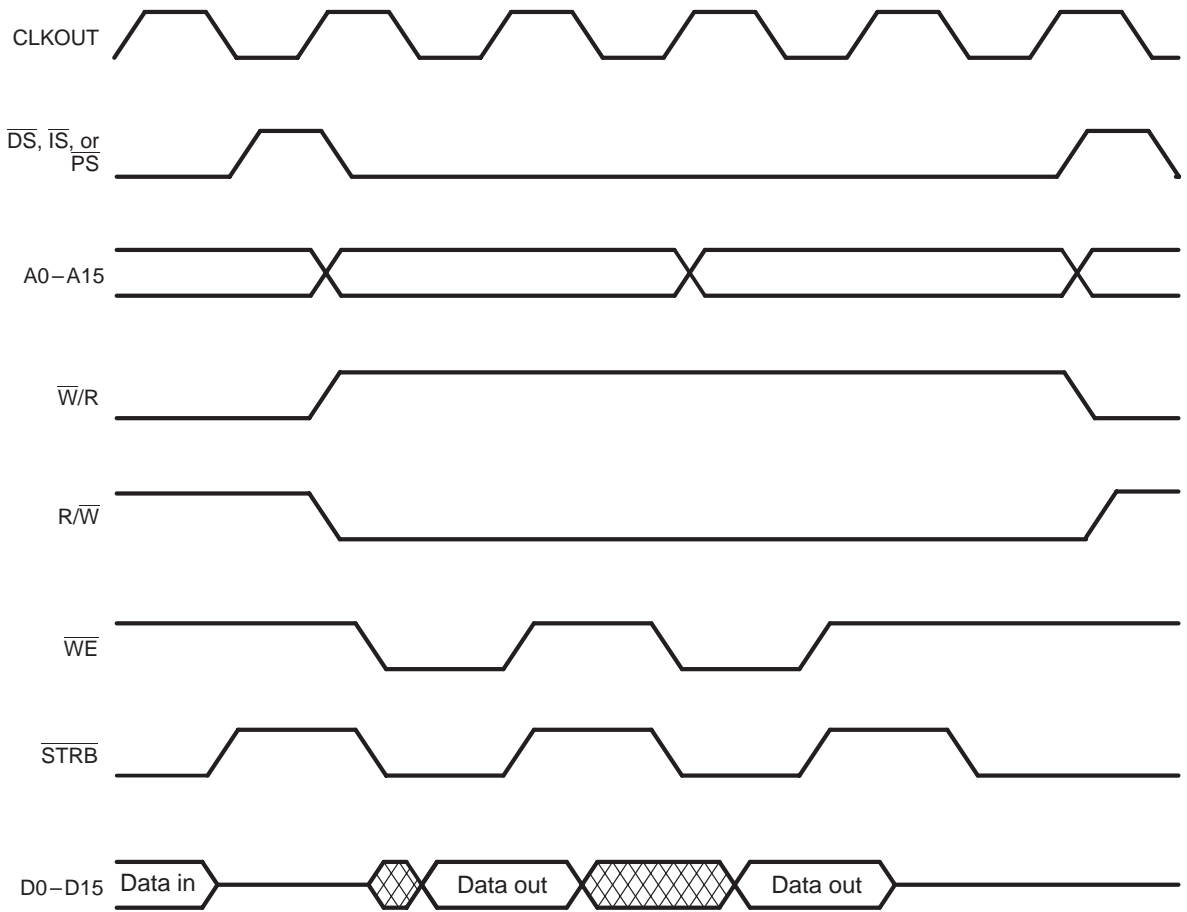

Figure 11–5. Memory Interface Write Waveforms



11.5 Wait-State Generator

Wait states can be generated when accessing slower external resources. Wait states operate on machine-cycle boundaries and are initiated either by using the ready signal or using the software wait-state generator. READY can be used to generate any number of wait states.

11.5.1 Generating Wait States With the READY Signal

By driving the READY signal high, an external device indicates that it is prepared for a bus transaction to be completed. If the external device is not ready, it can keep READY low for as long as it needs. When READY is low, the 'C240 waits one CLKOUT1 and checks READY again. The 'C240 does not continue executing until READY is driven high; if the READY signal is not used, it should be pulled high during external and internal accesses.

The READY pin can be used to generate any number of wait states. However, even when the 'C240 operates at full speed, it may not be able to respond fast enough to provide a READY-based wait state for the first cycle. To ensure that you have an immediate wait state(s), use the on-chip wait-state generator first and then the additional wait states can be generated using the READY signal.

11.5.2 Generating Wait States With the Wait-State Generator

The wait-state generator can be programmed to generate the first wait state for a given off-chip memory space (data, program, or I/O), regardless of the state of the READY signal. To control the wait-state generator, read or write to the wait-state generator control register (WSGR), mapped to I/O memory location FFFFh. Figure 11–6 shows the register bit layout.

Figure 11–6. Wait-State Generator Control Register (WSGR)



Note: W = Write, 0 = read by device as zeros, -1 = value after reset

- Bits 15–4** **Reserved.** Always read as 0.
- Bit 3** **AVIS.** Address visibility mode. At reset, this bit is set to 1. AVIS does not generate a wait state.
- 0 =Cleared; reduces power and noise (for production systems)
 - 1 =Enables the address visibility mode of the device. In this mode, the device provides a method of tracing the internal code operation: it passes the internal program address to the address bus when this bus is not used for an external access.
- Bit 2** **ISWS.** I/O space wait state bit. At reset, this bit is set to 1.
- 0 =No wait states are generated for off-chip I/O space.
 - 1 =One wait state will be applied to all accesses to off-chip I/O memory space.
- Bit 1** **DSWS.** Data space wait state bit. At reset, this bit is set to 1.
- 0 =No wait states are generated for off-chip data space.
 - 1 =One wait state will be applied to all accesses to off-chip data memory space.
- Bit 0** **PSWS.** Program space wait state bit. At reset, this bit is set to 1.
- 0 =No wait states are generated for off-chip program space.
 - 1 =One wait state will be applied to all accesses to off-chip program memory space.

In summary, the wait-state generator inserts a wait state to a given memory space (data, program, or I/O) if the corresponding bit in WSGR is set to 1, regardless of the condition of the READY signal. The READY signal can then be used to further extend wait states. The WSGR bits are all set to 1 by reset so that the device can operate from slow memory after reset.

Digital I/O Ports

This chapter contains a general description of the digital I/O ports module, and provides an overview of the method for controlling dedicated I/O and shared pin functions.

Topic	Page
12.1 Digital I/O Ports Overview	12-2
12-2 Digital I/O and Shared Pin Functions	12-2
12.3 Digital I/O Control Registers	12-6

12.1 Digital I/O Ports Overview

The digital I/O ports module provides a flexible method for controlling both dedicated I/O and shared pin functions. All I/O and shared pin functions are controlled using five 16-bit registers mapped within Peripheral File 9. These registers are divided into three types:

- Output control registers** — Used to directly control O/P pins.
- Data and direction control registers** — Used to control the data and the direction of the data to bidirectional I/O pins. The registers are directly connected to the bidirectional I/O pins.

12.2 Digital I/O and Shared Pin Functions

The 'C240 has a total of 28 pins shared between primary functions and I/Os. These pins are divided into two groups:

- Group1.** These are primary functions shared with I/Os belonging to dedicated I/O ports A, B, and C.
- Group2** These are primary functions belonging to peripheral modules that have a built-in I/O feature as a secondary function. Example are: SCI, SPI, external interrupts, and PLL clock module.

12.2.1 Description of Group1 Shared I/O Pins

The control structure for Group1 type shared I/O pins is shown in Figure 12–1 on page 12-3. The only exception to this configuration is the CLKOUT/IOPC1 pin described later in this section. In Figure 12–1, each pin has three bits which define its operation:

- MUX control bit.** This bit selects between the primary function (1) and I/O function (0) of the pin.
- I/O direction bit.** This bit determines whether the pin is an input (0) or output (1) when the I/O function is selected for the pin (MUX control bit is set to 0).
- I/O data bit.** Data is read from this bit if the I/O function is selected for the pin (MUX control bit is set to 0) and the direction selected is an input. Data is written to this bit if the direction selected is an output.

The MUX control bit, I/O direction bit, and I/O data bit are in the I/O control registers described in section 12.3, *Digital I/O control Registers*, on page 12-6.

Figure 12–1. Shared Pin Configuration

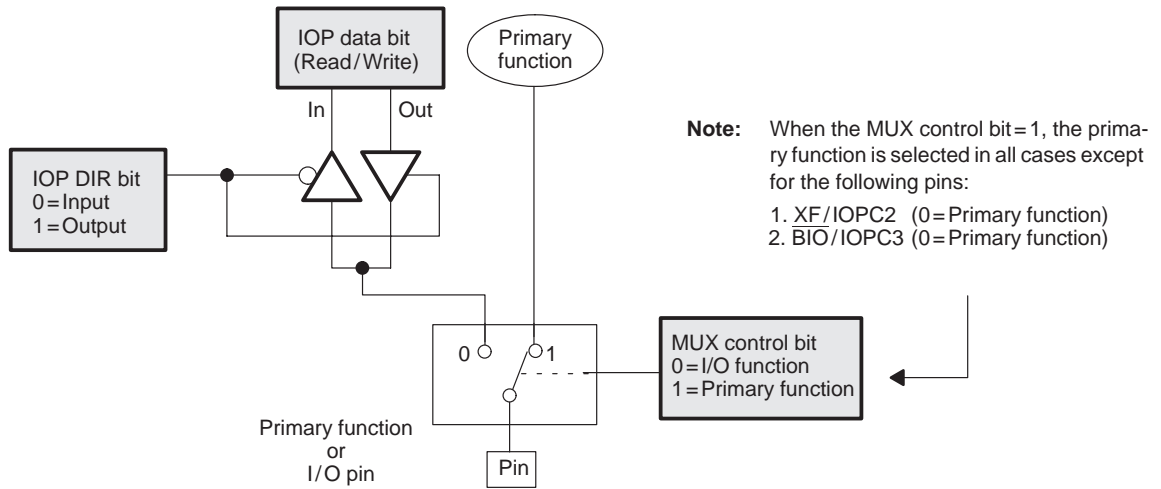

Table 12–1, *TMS320C240 Shared Pin Configuration*, on page 12-4 provides a summary of Group1 pin configurations and associated bits.

Table 12–1. TMS320C240 Shared Pin Configuration

Pin #	Mux Control Register (name.bit #)	Pin function selected		IO Port Data & Direction†		
		(CRx.n = 1)	(CRx.n = 0)	Register	Data bit #	Dir bit #
72	CRA.0	ADCIN0	IOPA0	PADATDIR	0	8
73	CRA.1	ADCIN1	IOPA1	PADATDIR	1	9
91	CRA.2	ADCIN9	IOPA2	PADATDIR	2	10
90	CRA.3	ADCIN8	IOPA3	PADATDIR	3	11
100	CRA.8	PWM7/CMP7	IOPB0	PBDATDIR	0	8
101	CRA.9	PWM8/CMP8	IOPB1	PBDATDIR	1	9
102	CRA.10	PWM9/CMP9	IOPB2	PBDATDIR	2	10
105	CRA.11	T1PWM/T1CMP	IOPB3	PBDATDIR	3	11
106	CRA.12	T2PWM/T2CMP	IOPB4	PBDATDIR	4	12
107	CRA.13	T3PWM/T3CMP	IOPB5	PBDATDIR	5	13
108	CRA.14	TMRDIR	IOPB6	PBDATDIR	6	14
109	CRA.15	TMRCLK	IOPB7	PBDATDIR	7	15
63	CRB.0	ADCSOC	IOPC0	PCDATDIR	0	8
64	SCR.7–6‡					
	0 0		IOPC1	PCDATDIR	1	9
	0 1		CLKOUT (Watchdog clock)	—	—	—
	1 0		CLKOUT (SYSCLK)	—	—	—
	1 1		CLKOUT (CPUCLK)	—	—	—
65	CRB.2	IOPC2	XF	PCDATDIR	2	10
66	CRB.3	IOPC3	\overline{BIO}	PCDATDIR	3	11
67	CRB.4	CAP1/QEP1	IOPC4	PCDATDIR	4	12
68	CRB.5	CAP2/QEP2	IOPC5	PCDATDIR	5	13
69	CRB.6	CAP3	IOPC6	PCDATDIR	6	14
70	CRB.7	CAP4	IOPC7	PCDATDIR	7	15

† Valid only if the I/O function is selected on the pin.

‡ SCR.7–6 = bits 7 and 6 in the system control register (see Chapter 6, *System Functions*).

12.2.2 Description of Group 2 Shared I/O Pins

Group 2 shared pins belong to peripherals which have built-in general purpose I/O capability. Control and configuration for these pins is achieved by setting appropriate bits within the control and configuration registers of the peripherals. Table 12–2 lists the Group 2 shared pins.

Table 12–2. Group 2 Shared Pins

Pin #	Primary Function	Peripheral Module
43	SCIRXD	SCI
44	SCITXD	SCI
45	SPISIMO	SPI
48	SPISOMI	SPI
49	SPICKL	SPI
51	SPISTE	SPI
54	XINT2	External interrupts
55	XINT3	External interrupts

For information on:

- The serial communications interface (SCI), see Chapter 8
- The serial peripheral interface (SPI), see Chapter 9
- External Interrupts, see Chapter 2, section 2.5.7 on page 2-61.

12.3 Digital I/O Control Registers

Table 12–3 lists the registers available to the digital I/O module. As with other 'C240 peripherals, these registers are memory mapped to the data space.

Table 12–3. Addresses of Digital I/O Control Registers

Address	Register	Name	Page
7090h	OCRA	I/O mux control register A	12-6
7092h	OCRB	I/O mux control register B	12-7
7098h	PADATDIR	I/O port A data and direction register	12-8
709Ah	PBDATDIR	I/O port B data and direction register	12-9
709Ch	PCDATDIR	I/O port C data and direction register	12-10

I/O mux control registers

Figure 12–2. I/O MUX Control Register A (OCRA) — Address 7090h

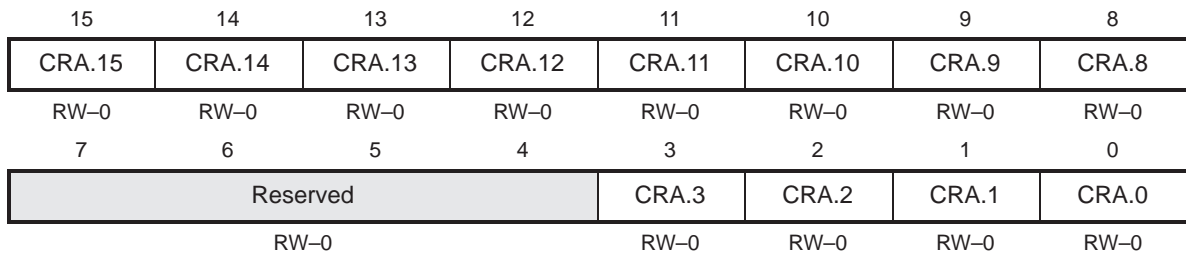

Note: R = read access, W = write access, -0 = value after reset

Table 12–4, I/O MUX Control Register A (OCRA) Configuration, on page 12-7 lists the pin functions and bits associated with OCRA.

Table 12–4. I/O MUX Control Register A (OCRA) Configuration

Bit #	Name.bit #	Pin function selected	
		(CRA.n = 1)	(CRA.n = 0)
0	CRA.0	ADCIN0	IOPA0
1	CRA.1	ADCIN1	IOPA1
2	CRA.2	ADCIN9	IOPA2
3	CRA.3	ADCIN8	IOPA3
8	CRA.8	PWM7/CMP7	IOPB0
9	CRA.9	PWM8/CMP8	IOPB1
10	CRA.10	PWM9/CMP9	IOPB2
11	CRA.11	T1PWM/T1CMP	IOPB3
12	CRA.12	T2PWM/T2CMP	IOPB4
13	CRA.13	T3PWM/T3CMP	IOPB5
14	CRA.14	TMRDIR	IOPB6
15	CRA.15	TMRCLK	IOPB7

Figure 12–3. I/O MUX Control Register B (OCRB) — Address 7092h

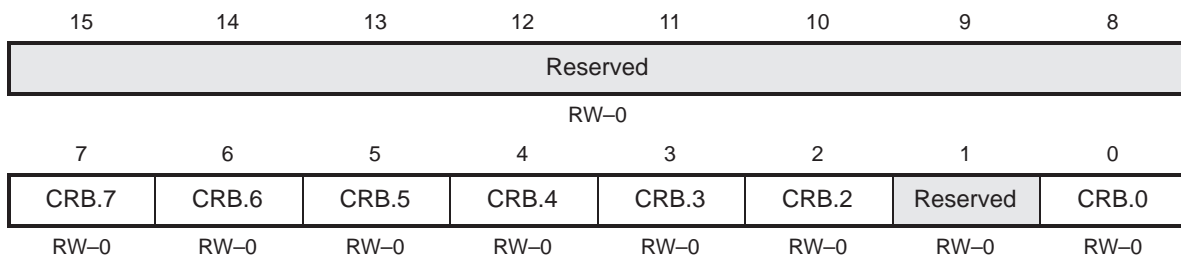

Note: R = read access, W = write access, –0 = value after reset

Table 12–5. I/O MUX Control Register B (OCRB) Configuration

Bit #	Name.bit #	Pin function selected	
		(CRB.n = 1)	(CRB.n = 0)
0	CRB.0	ADCSOC	IOPC0
2	CRB.2	IOPC2	XF
3	CRB.3	IOPC3	$\overline{\text{BIO}}$
4	CRB.4	CAP1/QEP1	IOPC4
5	CRB.5	CAP2/QEP2	IOPC5
6	CRB.6	CAP3	IOPC6
7	CRB.7	CAP4	IOPC7

I/O port data and direction registers

Figure 12–4. I/O Port A Data and Direction Register (PADATDIR) — Address 7098h

15	14	13	12	11	10	9	8
Reserved				A3DIR	A2DIR	A1DIR	A0DIR
				RW-0	RW-0	RW-0	RW-0
7	6	5	4	3	2	1	0
Reserved				IOPA3	IOPA2	IOPA1	IOPA0
				RW-0	RW-0	RW-0	RW-0

Note: R = read access, W = write access, -0 = value after reset, n = 0–3

Bits 15–12 Reserved

Bits 11–8 A3DIR–A0DIR. Port A direction control bits.

- 0 = Configure corresponding pin as an INPUT.
- 1 = Configure corresponding pin as an OUTPUT.

Bits 7–4 Reserved

Bits 3–0 IOPA3–IOPA0. Port A data bits.

If AnDIR = 0, then:

- 0 = Corresponding I/O pin is read as a LOW.
- 1 = Corresponding I/O pin is read as a HIGH.

If AnDIR = 1, then:

- 0 = Set corresponding I/O pin to an output LOW level.
- 1 = Set corresponding I/O pin to an output HIGH level.

Figure 12–5. I/O Port B Data and Direction Register (PBDATDIR) — Address 709Ah

15	14	13	12	11	10	9	8
B7DIR	B6DIR	B5DIR	B4DIR	B3DIR	B2DIR	B1DIR	B0DIR
RW-0	RW-0	RW-0	RW-0	RW-0	RW-0	RW-0	RW-0
7	6	5	4	3	2	1	0
IOPB7	IOPB6	IOPB5	IOPB4	IOPB3	IOPB2	IOPB1	IOPB0
RW-0	RW-0	RW-0	RW-0	RW-0	RW-0	RW-0	RW-0

Note: R = read access, W = write access, -0 = value after reset, n = 0–7

Bits 15–8 B7DIR–B0DIR. Port B direction control bits.

- 0 = Configure corresponding pin as an INPUT.
- 1 = Configure corresponding pin as an OUTPUT.

Bits 7–0 IOPB7–IOPB0. Port B data bits.

If BnDIR = 0, then:

- 0 = Corresponding I/O pin is read as a LOW.
- 1 = Corresponding I/O pin is read as a HIGH.

If BnDIR = 1, then:

- 0 = Set corresponding I/O pin to an output LOW level.
- 1 = Set corresponding I/O pin to an output HIGH level.

Figure 12–6. I/O Port C Data and Direction Register (PCDATDIR) — Address 709Ch

15	14	13	12	11	10	9	8
C7DIR	C6DIR	C5DIR	C4DIR	C3DIR	C2DIR	C1DIR	C0DIR
RW-0	RW-0	RW-0	RW-0	RW-0	RW-0	RW-0	RW-0
7	6	5	4	3	2	1	0
IOPC7	IOPC6	IOPC5	IOPC4	IOPC3	IOPC2	IOPC1	IOPC0
RW-0	RW-0	RW-0	RW-0	RW-0	RW-0	RW-0	RW-0

Note: R = read access, W = write access, -0 = value after reset, n = 0–7

Bits 15–8 C7DIR–C0DIR. Port C direction control bits.

- 0 = Configure corresponding pin as an INPUT.
- 1 = Configure corresponding pin as an OUTPUT.

Bits 7–0 IOPC7–IOPC0. Port C data bits.

If CnDIR = 0, then:

- 0 = Corresponding I/O pin is read as a LOW.
- 1 = Corresponding I/O pin is read as a HIGH.

If CnDIR = 1, then:

- 0 = Set corresponding I/O pin to an output LOW level.
- 1 = Set corresponding I/O pin to an output HIGH level.

Summary of Programmable Registers on the TMS320F/C240

Topic	Page
A.1 CPU Registers	A-6
A.2 Watchdog (WD) and Real-time Interrupt (RTI) Registers	A-9
A.3 PLL Clock Registers	A-11
A.4 Dual 10-Bit Analog to Digital Converter (ADC) Registers	A-12
A.5 Serial Peripheral Interface (SPI) Registers	A-14
A.6 Serial Communications Interface (SCI) Registers	A-17
A.7 External Interrupt Control Registers	A-20
A.8 Digital I/O Control Registers	A-21
A.9 General Purpose (GP) Timer Registers	A-23
A.10 Compare Unit Registers	A-28
A.11 Capture Unit Registers	A-32
A.12 Dead-Band Timer Control Register	A-35
A.13 Event Manager (EV) Interrupt Registers	A-36
A.14 Flash Control Mode Register—Including Flash Segment Control Register	A-39
A.15 Wait-State Generator Control Register	A-40

Table A–1 provides a summary of all programmable registers on the '240.

Table A–1. Addresses of TMS320F/C240 Registers

Address	Register	Name	Shown in	
			Figure	Page
Internal	ST0	Status register 0	Figure A–1	A-6
Internal	ST1	Status register 1	Figure A–2	A-6
0004h	IMR	Interrupt mask register	Figure A–3	A-7
0005h	GREG	Global memory allocation register	Figure A–4	A-7
0006h	IFR	Interrupt flag register	Figure A–5	A-7
7018h	SYSCR	System control register	Figure A–6	A-7
701Ah	SYSSR	System status register	Figure A–7	A-8
701Eh	SYSIVR	System interrupt vector register	Figure A–8	A-8
7021h	RTICNTR	Real-time interrupt counter register	Figure A–9	A-9
7023h	WDCNTR	Watchdog counter register	Figure A–10	A-9
7025h	WDKEY	Watchdog reset key register	Figure A–11	A-10
7027h	RTICR	Real-time interrupt control register	Figure A–12	A-10
7029h	WDCR	Watchdog timer control register	Figure A–13	A-10
702Bh	CKCR0	Clock control register 0	Figure A–14	A-11
702Dh	CKCR1	Clock control register 1	Figure A–15	A-11
7032h	ADCTRL1	ADC control register 1	Figure A–16	A-12
7034h	ADCTRL2	ADC control register 2	Figure A–17	A-12
7036h	ADCFIFO1	ADC data register FIFO 1	Figure A–18	A-13
7038h	ADCFIFO2	ADC data register FIFO 2	Figure A–19	A-13
7040h	SPICCR	SPI configuration control register	Figure A–20	A-14
7041h	SPICTL	SPI operation control register	Figure A–21	A-14
7042h	SPISTS	SPI status register	Figure A–22	A-14
7044h	SPIBRR	SPI baud rate register	Figure A–23	A-14
7046h	SPIEMU	SPI emulation buffer register	Figure A–24	A-15

Table A–1. Addresses of TMS320F/C240 Registers (Continued)

Address	Register	Name	Shown in	
			Figure	Page
7047h	SPIBUF	SPI serial input buffer register	Figure A–25	A-15
7049h	SPIDAT	SPI serial data register	Figure A–26	A-15
704Dh	SPIPC1	SPI port control register 1	Figure A–27	A-15
704Eh	SPIPC2	SPI port control register 2	Figure A–28	A-16
704Fh	SPIPRI	SPI priority control register	Figure A–29	A-16
7050h	SCICCR	SCI communication control register	Figure A–30	A-17
7051h	SCICTL1	SCI control register 1	Figure A–31	A-17
7052h	SCIHBAUD	SCI baud select register, high bits	Figure A–32	A-17
7053h	SCILBAUD	SCI baud select register, low bits	Figure A–33	A-17
7054h	SCICTL2	SCI control register 2	Figure A–34	A-18
7055h	SCIRXST	SCI receiver status register	Figure A–35	A-18
7056h	SCIRXEMU	SCI emulation data buffer register	Figure A–36	A-18
7057h	SCIRXBUF	SCI receiver data buffer register	Figure A–37	A-18
7059h	SCITXBUF	SCI transmit data buffer register	Figure A–38	A-19
705Eh	SCIPC2	SCI port control register 2	Figure A–39	A-19
705Fh	SCIPRI	SCI priority control register	Figure A–40	A-19
7070h	XINT1CR	External interrupt 1 control register	Figure A–41	A-20
7072h	NMICR	Nonmaskable interrupt control register	Figure A–42	A-20
7078h	XINT2CR	External interrupt 2 control register	Figure A–43	A-20
707Ah	XINT3CR	External interrupt 3 control register	Figure A–44	A-20
7090h	OCRA	I/O mux control register A	Figure A–45	A-21
7092h	OCRB	I/O mux control register B	Figure A–46	A-21
7098h	PADATDIR	I/O port A data and direction register	Figure A–47	A-22
709Ah	PBDATDIR	I/O port B data and direction register	Figure A–48	A-22
709Ch	PCDATDIR	I/O port C data and direction register	Figure A–49	A-22

Table A–1. Addresses of TMS320F/C240 Registers (Continued)

Address	Register	Name	Shown in	
			Figure	Page
7400h	GPTCON	General purpose timer control register	Figure A–50	A-23
7401h	T1CNT	GP Timer 1 counter register	Figure A–51	A-23
7402h	T1CMPR	GP Timer 1 compare register	Figure A–52	A-24
7403h	T1PR	GP Timer 1 period register	Figure A–53	A-24
7404h	T1CON	GP Timer 1 control register	Figure A–54	A-24
7405h	T2CNT	GP Timer 2 counter register	Figure A–55	A-25
7406h	T2CMPR	GP Timer 2 compare register	Figure A–56	A-25
7407h	T2PR	GP Timer 2 period register	Figure A–57	A-25
7408h	T2CON	GP Timer 2 control register	Figure A–58	A-26
7409h	T3CNT	GP Timer 3 counter register	Figure A–59	A-26
740Ah	T3CMPR	GP Timer 3 compare register	Figure A–60	A-26
740Bh	T3PR	GP Timer 3 period register	Figure A–61	A-27
740Ch	T3CON	GP Timer 3 control register	Figure A–62	A-27
7411h	COMCON	Compare control register	Figure A–63	A-28
7413h	ACTR	Full-compare action control register	Figure A–64	A-28
7414h	SACTR	Simple-compare action control register	Figure A–68	A-30
7415h	DBTCON	Dead-band timer control register	Figure A–78	A-35
7417h	CMPR1	Full-compare unit compare register 1	Figure A–65	A-29
7418h	CMPR2	Full-compare unit compare register 2	Figure A–66	A-29
7419h	CMPR3	Full-compare unit compare register 3	Figure A–67	A-29
741Ah	SCMPR1	Simple-compare unit compare register 1	Figure A–69	A-30
741Bh	SCMPR2	Simple-compare unit compare register 2	Figure A–70	A-30
741Ch	SCMPR3	Simple-compare unit compare register 3	Figure A–71	A-31
7420h	CAPCON	Capture control register	Figure A–72	A-32
7422h	CAPFIFO	Capture FIFO status register	Figure A–73	A-32

Table A–1. Addresses of TMS320F/C240 Registers (Continued)

Address	Register	Name	Shown in	
			Figure	Page
7423h	CAP1FIFO	Capture 1 FIFO stack register	Figure A–74	A-33
7424h	CAP2FIFO	Capture 2 FIFO stack register	Figure A–75	A-33
7425h	CAP3FIFO	Capture 3 FIFO stack register	Figure A–76	A-33
7426h	CAP4FIFO	Capture 4 FIFO stack register	Figure A–77	A-34
742Ch	EVIMRA	EV interrupt mask register A	Figure A–79	A-36
742Dh	EVIMRB	EV interrupt mask register B	Figure A–80	A-36
742Eh	EVIMRC	EV interrupt mask register C	Figure A–81	A-36
742Fh	EVIFRA	EV interrupt flag register A	Figure A–82	A-37
7430h	EVIFRB	EV interrupt flag register B	Figure A–83	A-37
7431h	EVIFRC	EV interrupt flag register C	Figure A–84	A-37
7432h	EVIVRA	EV interrupt vector register A	Figure A–85	A-38
7433h	EVIVRB	EV interrupt vector register B	Figure A–86	A-38
7434h	EVIVRC	EV interrupt vector register C	Figure A–87	A-38
FF0Fh†	FCMR	Flash control mode register	Figure A–88	A-39
0h‡	SEG_CTR	Flash segment control register	Figure A–89	A-39
FFFFh†	WSGR	Wait-state generator control register	Figure A–90	A-40

† Address in I/O space

‡ Address in program memory space

A.1 CPU Registers

CPU status registers (ST0 and ST1)

Figure A–1. Status Register 0 (ST0) — Internal CPU Register

15	14	13	12	11	10	9	8	7	6	5	4	3	2	1	0
ARP		OV	OVM	1	INTM	DP									
RW-x		RW-0	RW-x	Rsvd	RW-1	RW-x									

Note: R = Read access; W = Write access; value following dash (-) is value after reset (x means value not affected by reset). Reserved bit is always read as 1. Writes have no effect on it.

Figure A–2. Status Register 1 (ST1) — Internal CPU Register

15	14	13	12	11	10	9	8	7	6	5	4	3	2	1	0
ARB		CNF	TC	SXM	C	1	1	1	1	XF	1	1	PM		
RW-x		RW-0	RW-x	RW-1	RW-1	Reserved				RW-1	Rsvd	RW-00			

Note: R = Read access; W = Write access; value following dash (-) is value after reset (x means value not affected by reset). Reserved bits are always read as 1s. Writes have no effect on them.

CPU interrupt and allocation registers (IMR, IFR, and GREG)

Figure A-3. Interrupt Mask Register (IMR) — Address 0004h

15-6	5	4	3	2	1	0
Reserved	INT6 mask	INT5 mask	INT4 mask	INT3 mask	INT2 mask	INT1 mask
0	RW-0	RW-0	RW-0	RW-0	RW-0	RW-0

Note: R = read access, W = write access, -0 = value after reset

Figure A-4. Global Memory Allocation Register (GREG) — Address 0005h

15-8	7	6	5	4	3	2	1	0
Reserved	Global data memory configuration bits							
RW-0								

Note: R = read access, W = write access, -0 = value after reset

Figure A-5. Interrupt Flag Register (IFR) — Address 0006h

15-6	5	4	3	2	1	0
Reserved	INT6 flag	INT5 flag	INT4 flag	INT3 flag	INT2 flag	INT1 flag
0	RW1C-0	RW1C-0	RW1C-0	RW1C-0	RW1C-0	RW1C-0

Note: R = read access, W1C = write 1 to clear, -0 = value after reset

System control register (SYSCR)

Figure A-6. System Control Register (SYSCR) — Address 7018h

15	14	13-8	7	6	5-0
RESET1	RESET0	Reserved	CLKSRC1	CLKSRC0	Reserved
RW-0	RW-1		RW-1*	RW-1*	

Note: R = Read access, W = Write access, -n = Value after reset,
* = Not affected by reset, set to 1 by power-on reset

System status register (SYSSR)

Figure A-7. System Status Register (SYSSR) — Address 701Ah

15	14-13	12	11	10	9	8-6	5	4	3	2-1	0
PORST	Res	ILLADR	Res	SWRST	WDRST	Res	HPO	Res	VCCAOR	Res	VECRD
RC-x		RC-x		RC-x	RC-x		RC-i		R-1		R-0

Note: R = Read access, C = Clear-only write access, -n = Value after reset (x means value unchanged by reset),
 -i = Value of VCCP pin latch on rising edge of RESET

System Interrupt Vector Register (SYSIVR)

The system interrupt vector register is a read-only register.

Figure A-8. System Interrupt Vector Register (SYSIVR) — Address 701Eh

15	14	13	12	11	10	9	8	7	6	5	4	3	2	1	0
0	0	0	0	0	0	0	0	D7	D6	D5	D4	D3	D2	D1	D0
R-0															

Note: R = Read access, -0 = Value after reset

A.2 Watchdog (WD) and Real-time Interrupt (RTI) Registers

Real-time interrupt counter register (RTICNTR)

Figure A–9. Real-Time Interrupt Counter Register (RTICNTR) — Address 7021h

7	6	5	4	3	2	1	0
D7	D6	D5	D4	D3	D2	D1	D0
RC–0	RC–0	RC–0	RC–0	RC–0	RC–0	RC–0	RC–0

Note: R = read access, C = clear, –0 = value after reset

Watchdog counter register (WDCNTR)

Figure A–10. Watchdog Counter Register (WDCNTR) — Address 7023h

7	6	5	4	3	2	1	0
D7	D6	D5	D4	D3	D2	D1	D0
R–0	R–0	R–0	R–0	R–0	R–0	R–0	R–0

Note: R = read access, –0 = value after reset

Watchdog reset key register (WDKEY)

Figure A–11. Watchdog Reset Key Register (WDKEY) — Address 7025h

7	6	5	4	3	2	1	0
D7	D6	D5	D4	D3	D2	D1	D0
RW-0	RW-0	RW-0	RW-0	RW-0	RW-0	RW-0	RW-0

Note: R = read access, W = write access, -0 = value after reset

Real-time interrupt control register (RTICR)

Figure A–12. Real-Time Interrupt Control Register (RTICR) — Address 7027h

7	6	5 – 3	2	1	0
RTI FLAG	RTI ENA	Reserved	RTIPS2	RTIPS1	RTIPS0
RW-0	RW-0		RW-0	RW-0	RW-0

Note: R = read access, W = write access, -0 = value after reset

Watchdog timer control register (WDCR)

Figure A–13. Watchdog Timer Control Register (WDCR) — Address 7029h

7	6	5	4	3	2	1	0
WD FLAG	WDDIS	WDCHK2	WDCHK1	WDCHK0	WDPS2	WDPS1	WDPS0
RW-x		RW-0	RW-0	RW-0	RW-0	RW-0	RW-0

Note: R = read access, W = write access, -n = value after reset (x = indeterminate)

A.3 PLL Clock Registers

Clock control register 0 (CKCR0)

Figure A–14. Clock Control Register 0 (CKCR0) — Address 702Bh

7	6	5	4	3	2	1	0
CLKMD(1)	CLKMD(0)	PLLOCK(1)	PLLOCK(0)	PLLPM(1)	PLLPM(0)	Reserved	PLLPS
RW-x	RW-x	R-x	R-x	RW-0	RW-0		RW-0

Note: R = read access; W = write access; -x = not affected by system reset, cleared to 0 by power on reset

Clock control register 1 (CKCR1)

Figure A–15. Clock Control Register 1 (CKCR1) — Address 702Dh

7	6	5	4	3	2	1	0
CKINF(3)	CKINF(2)	CKINF(1)	CKINF(0)	PLLDIV(2)	PLLFB(2)	PLLFB(1)	PLLFB(0)
RW-x	RW-x	RW-x	RW-x	RW-x	RW-x	RW-x	RW-x

Note: R = read access; W = write access; -x = not affected by system reset, cleared to 0 by power on reset

A.4 Dual 10-Bit Analog to Digital Converter (ADC) Registers

ADC control registers (ADCTRL1 and ADCTRL2)

Figure A–16. ADC Control Register 1 (ADCTRL1) — Address 7032h

15	14	13	12	11	10	9	8
Suspend-soft	Suspend-free	ADCMSTART	ADC1EN	ADC2EN	ADCCONRUN	ADCINTEN	ADCINTFLAG
7	6–4	3–1	0				
ADCEOC	ADC2CHSEL	ADC1CHSEL	ADCSOC				
R–0	SRW–0	SRW–0	SRW–0				

Note: R = read access, W = write, S = shadowed, –0 = value after reset

Figure A–17. ADC Control Register 2 (ADCTRL2) — Address 7034h

15–11	10	9	8
Reserved	ADCEVSOC	ADCEXTSOC	Reserved
	SRW–0	SRW–0	
7–6	5	4–3	2–0
ADCFIFO2	Reserved	ADCFIFO1	ADCPSCALE
R–0		R–0	SRW–0

Note: R = read access, W = write, S = shadowed, –0 = value after reset

ADC data registers*Figure A–18. ADC Data Register FIFO1 (ADCFIFO1) — Address 7036h*

15	14	13	12	11	10	9	8
D9	D8	D7	D6	D5	D4	D3	D2
RW–0	RW–0	RW–0	RW–0	RW–0	RW–0	RW–0	RW–0
7	6	5	4	3	2	1	0
D1	D0	0	0	0	0	0	0
RW–0	RW–0	RW–0	RW–0	RW–0	RW–0	RW–0	RW–0

Note: R = read access, W = write access, –0 = value after reset

Figure A–19. ADC Data Register FIFO2 (ADCFIFO2) — Address 7038h

15	14	13	12	11	10	9	8
D9	D8	D7	D6	D5	D4	D3	D2
RW–0	RW–0	RW–0	RW–0	RW–0	RW–0	RW–0	RW–0
7	6	5	4	3	2	1	0
D1	D0	0	0	0	0	0	0
RW–0	RW–0	RW–0	RW–0	RW–0	RW–0	RW–0	RW–0

Note: R = read access, W = write access, –0 = value after reset

A.5 Serial Peripheral Interface (SPI) Registers

SPI configuration control register (SPICCR)

Figure A–20. SPI Configuration Control Register (SPICCR) — Address 7040h

7	6	5 – 3	2	1	0
SPI SW reset	Clock polarity	Reserved	SPI CHAR2	SPI CHAR1	SPI CHAR0
RW–0	RW–0		RW–0	RW–0	RW–0

Note: R = read access, W = write access, –0 = value after reset

SPI operation control register (SPICTL)

Figure A–21. SPI Operation Control Register (SPICTL) — Address 7041h

7 – 5	4	3	2	1	0
Reserved	Overrun INT ENA	Clock phase	Master/slave	TALK	SPI INT ENA
	RW–0	RW–0	RW–0	RW–0	RW–0

Note: R = read access, W = write access, –0 = value after reset

SPI status register (SPISTS)

Figure A–22. SPI Status Register (SPISTS) — Address 7042h

7	6	5 – 0
Receiver overrun	SPI INT flag	Reserved
RC–0	R–0	

Note: R = read access, –0 = value after reset, C = clear

SPI baud rate register (SPIBRR)

Figure A–23. SPI Baud Rate Register (SPIBRR) — Address 7044h

7	6	5	4	3	2	1	0
Reserved	SPI bit rate 6	SPI bit rate 5	SPI bit rate 4	SPI bit rate 3	SPI bit rate 2	SPI bit rate 1	SPI bit rate 0
	RW–0	RW–0	RW–0	RW–0	RW–0	RW–0	RW–0

Note: R = read access, W = write access, –0 = value after reset

SPI emulation buffer register (SPIEMU)

Figure A–24. SPI Emulation Buffer Register (SPIEMU) — Address 7046h

7	6	5	4	3	2	1	0
ERCVD7	ERCVD6	ERCVD5	ERCVD4	ERCVD3	ERCVD2	ERCVD1	ERCVD0
R-x	R-x	R-x	R-x	R-x	R-x	R-x	R-x

Note: R = read access, -n = value after reset (x = indeterminate)

SPI serial input buffer register (SPIBUF)

Figure A–25. SPI Serial Input Buffer Register (SPIBUF) — Address 7047h

7	6	5	4	3	2	1	0
RCVD7	RCVD6	RCVD5	RCVD4	RCVD3	RCVD2	RCVD1	RCVD0
R-x	R-x	R-x	R-x	R-x	R-x	R-x	R-x

Note: R = read access, -n = value after reset (x = indeterminate)

SPI serial data register (SPIDAT)

Figure A–26. SPI Serial Data Register (SPIDAT) — Address 7049h

7	6	5	4	3	2	1	0
SDAT7	SDAT6	SDAT5	SDAT4	SDAT3	SDAT2	SDAT1	SDAT0
RW-x	RW-x	RW-x	RW-x	RW-x	RW-x	RW-x	RW-x

Note: R = read access, W = write access, -n = value after reset (x = indeterminate)

SPI port control register 1 (SPIPC1)

Figure A–27. SPI Port Control Register 1 (SPIPC1) — Address 704Dh

7	6	5	4	3	2	1	0
SPISTE data in	SPISTE data out	SPISTE function	SPISTE data dir	SPICLK data in	SPICLK data out	SPICLK function	SPICLK data dir
R-x	RW-0	RW-0	RW-0	R-x	RW-0	RW-0	RW-0

Note: R = read access, W = write access, -n = value after reset (x = indeterminate)

SPI port control register 2 (SPIPC2)

Figure A–28. SPI Port Control Register 2 (SPIPC2) — Address 704Eh

7	6	5	4	3	2	1	0
SPISIMO data in	SPISIMO data out	SPISIMO function	SPISIMO data dir	SPISOMI data in	SPISOMI data out	SPISOMI function	SPISOMI data dir
R-x	RW-0	RW-0	RW-0	R-x	RW-0	RW-0	RW-0

Note: R = read access, W = write access, -n = value after reset (x = indeterminate)

SPI priority control register (SPIPRI)

Figure A–29. SPI Priority Control Register (SPIPRI) — Address 704Fh

7	6	5	4 – 0
Reserved	SPI PRIORITY	SPI ESPEN	Reserved
	RW-0	RW-0	

Note: R = read access, W = write access, -0 = value after reset

A.6 Serial Communications Interface (SCI) Registers

SCI communication control register (SCICCR)

Figure A–30. SCI Communication Control Register (SCICCR) — Address 7050h

7	6	5	4	3	2	1	0
Stop bit	Even/odd parity	Parity enable	SCI ENA	ADDR/IDLE mode	SCI CHAR2	SCI CHAR1	SCI CHAR0
RW–0	RW–0	RW–0	RW–0	RW–0	RW–0	RW–0	RW–0

Note: R = read access, W = write access, –0 = value after reset

SCI control register 1 (SCICTL1)

Figure A–31. SCI Control Register 1 (SCICTL1) — Address 7051h

7	6	5	4	3	2	1	0
Reserved	RX ERR INT ENA	SW reset	Clock ENA	TXWAKE	Sleep	TXENA	RXENA
	RW–0	RW–0	RW–0	RS–0	RW–0	RW–0	RW–0

Note: R = read access, W = write access, S = set only, –0 = value after reset

SCI baud-select registers (SCIHBAUD and SCILBAUD)

Figure A–32. SCI Baud-Select Register, High Bits (SCIHBAUD) — Address 7052h

15	14	13	12	11	10	9	8
BAUD15 (MSB)	BAUD14	BAUD13	BAUD12	BAUD11	BAUD10	BAUD9	BAUD8
RW–0	RW–0	RW–0	RW–0	RW–0	RW–0	RW–0	RW–0

Note: R = read access, W = write access, –0 = value after reset

Figure A–33. SCI Baud-Select Register, Low Bits (SCILBAUD) — Address 7053h

7	6	5	4	3	2	1	0
BAUD7	BAUD6	BAUD5	BAUD4	BAUD3	BAUD2	BAUD1	BAUD0 (LSB)
RW–0	RW–0	RW–0	RW–0	RW–0	RW–0	RW–0	RW–0

Note: R = read access, W = write access, –0 = value after reset

SCI control register 2 (SCICTL2)

Figure A–34. SCI Control Register 2 (SCICTL2) — Address 7054h

7	6	5–2	1	0
TXRDY	TX empty	Reserved	RX/BK INT ENA	TX INT ENA
R–1	R–1		RW–0	RW–0

Note: R = read access, W = write access, –n = value after reset

SCI receiver status register (SCIRXST)

Figure A–35. SCI Receiver Status Register (SCIRXST) — Address 7055h

7	6	5	4	3	2	1	0
RX error	RXRDY	BRKDT	FE	OE	PE	RXWAKE	Reserved
R–0	R–0	R–0	R–0	R–0	R–0	R–0	

Note: R = read access, –0 = value after reset

SCI emulation data buffer register (SCIRXEMU)

Figure A–36. SCI Emulation Data Buffer Register (SCIRXEMU) — Address 7056h

7	6	5	4	3	2	1	0
ERXDT7	ERXDT6	ERXDT5	ERXDT4	ERXDT3	ERXDT2	ERXDT1	ERXDT0
R–x	R–x	R–x	R–x	R–x	R–x	R–x	R–x

Note: R = read access, –n = value after reset (x = indeterminate)

SCI receiver data buffer register (SCIRXBUF)

Figure A–37. SCI Receiver Data Buffer Register (SCIRXBUF) — Address 7057h

7	6	5	4	3	2	1	0
RXDT7	RXDT6	RXDT5	RXDT4	RXDT3	RXDT2	RXDT1	RXDT0
R–x	R–x	R–x	R–x	R–x	R–x	R–x	R–x

Note: R = Read access, –n = value after reset (x = indeterminate)

SCI transmit data buffer register (SCITXBUF)

Figure A–38. SCI Transmit Data Buffer Register (SCITXBUF) — Address 7059h

7	6	5	4	3	2	1	0
TXDT7	TXDT6	TXDT5	TXDT4	TXDT3	TXDT2	TXDT1	TXDT0
RW–0	RW–0	RW–0	RW–0	RW–0	RW–0	RW–0	RW–0

Note: R = read access, W = write access, –0 = value after reset

SCI port control register 2 (SCIPC2)

Figure A–39. SCI Port Control Register 2 (SCIPC2) — Address 705Eh

7	6	5	4	3	2	1	0
SCITXD data in	SCITXD data out	SCITXD function	SCITXD data dir	SCIRXD data in	SCIRXD data out	SCIRXD function	SCIRXD data dir
R–x	RW–0	RW–0	RW–0	R–x	RW–0	RW–0	RW–0

Note: R = read access, W = write access, –n = value after reset (x = indeterminate)

SCI priority control register (SCIPRI)

Figure A–40. SCI Priority Control Register (SCIPRI) — Address 705Fh

7	6	5	4	3–0
Reserved	SCITX PRIORITY	SCIRX PRIORITY	SCI ESPEN	Reserved
	RW–0	RW–0	RW–0	

Note: R = read access, W = write access, –0 = value after reset

A.7 External Interrupt Control Registers

Figure A–41. External Interrupt 1 Control Register (XINT1CR) — Address 7070h

15	14–7	6	3–5	2	1	0
INT1 flag	Reserved	INT1 pin data	Reserved	INT1 polarity	INT1 priority	INT1 enable
R/C–0		R–p		R/W–0	R/W–0	R/W–0

Note: R = Read access, W = Write access, C = Clear-only write access, –n = Value after reset (x means value unchanged by reset), –p = Logic level of pin

Figure A–42. Nonmaskable Interrupt Control Register (NMICR) — Address 7072h

15	14–7	6	3–5	2	1–0
NMI flag	Reserved	NMI pin data	Reserved	NMI polarity	Reserved

Figure A–43. External Interrupt 2 Control Register (XINT2CR) — Address 7078h

15	14–7	6	5	4	3	2	1	0
XINT2 flag	Reserved	XINT2 pin data	Reserved	XINT2 data dir	XINT2 data out	XINT2 polarity	XINT2 priority	XINT2 enable
R/C–0		R–p	R/W–0	R/W–0	R/W–0	R/W–0	R/W–0	R/W–0

Note: R = Read access, W = Write access, C = Clear-only write access, –n = Value after reset, –p = Logic level of pin

Figure A–44. External Interrupt 3 Control Register (XINT3CR) — Address 707Ah

15	14–7	6	5	4	3	2	1	0
XINT3 flag	Reserved	XINT3 pin data	Reserved	XINT3 data dir	XINT3 data out	XINT3 polarity	XINT3 priority	XINT3 enable
R/C–0		R–p		R/W–0	R/W–0	R/W–0	R/W–0	R/W–0

Note: R = Read access, W = Write access, C = Clear-only write access, –n = Value after reset, –p = Logic level of pin

A.8 Digital I/O Control Registers

I/O MUX control registers (OCRA and OCRB)

Figure A–45. I/O MUX Control Register A (OCRA) — Address 7090h

15	14	13	12	11	10	9	8
CRA.15	CRA.14	CRA.13	CRA.12	CRA.11	CRA.10	CRA.9	CRA.8
RW–0	RW–0	RW–0	RW–0	RW–0	RW–0	RW–0	RW–0
7	6	5	4	3	2	1	0
Reserved				CRA.3	CRA.2	CRA.1	CRA.0
RW–0				RW–0	RW–0	RW–0	RW–0

Note: R = read access, W = write access, –0 = value after reset

Figure A–46. I/O MUX Control Register B (OCRB) — Address 7092h

15	14	13	12	11	10	9	8
Reserved							
RW–0							
7	6	5	4	3	2	1	0
CRB.7	CRB.6	CRB.5	CRB.4	CRB.3	CRB.2	CRB.1	CRB.0
RW–0	RW–0	RW–0	RW–0	RW–0	RW–0	RW–0	RW–0

Note: R = read access, W = write access, –0 = value after reset

I/O port data and direction registers (PADATDIR, PBDATDIR, and PCDATDIR)

Figure A–47. I/O Port A Data and Direction Register (PADATDIR) — Address 7098h

15	14	13	12	11	10	9	8
Reserved				A3DIR	A2DIR	A1DIR	A0DIR
				RW-0	RW-0	RW-0	RW-0
7	6	5	4	3	2	1	0
Reserved				IOPA3	IOPA2	IOPA1	IOPA0
				RW-0	RW-0	RW-0	RW-0

Note: R = read access, W = write access, -0 = value after reset

Figure A–48. I/O Port B Data and Direction Register (PBDATDIR) — Address 709Ah

15	14	13	12	11	10	9	8
B7DIR	B6DIR	B5DIR	B4DIR	B3DIR	B2DIR	B1DIR	B0DIR
RW-0	RW-0	RW-0	RW-0	RW-0	RW-0	RW-0	RW-0
7	6	5	4	3	2	1	0
IOPB7	IOPB6	IOPB5	IOPB4	IOPB3	IOPB2	IOPB1	IOPB0
RW-0	RW-0	RW-0	RW-0	RW-0	RW-0	RW-0	RW-0

Note: R = read access, W = write access, -0 = value after reset

Figure A–49. I/O Port C Data and Direction Register (PCDATDIR) — Address 709Ch

15	14	13	12	11	10	9	8
C7DIR	C6DIR	C5DIR	C4DIR	C3DIR	C2DIR	C1DIR	C0DIR
RW-0	RW-0	RW-0	RW-0	RW-0	RW-0	RW-0	RW-0
7	6	5	4	3	2	1	0
IOPC7	IOPC6	IOPC5	IOPC4	IOPC3	IOPC2	IOPC1	IOPC0
RW-0	RW-0	RW-0	RW-0	RW-0	RW-0	RW-0	RW-0

Note: R = read access, W = write access, -0 = value after reset

A.9 General Purpose (GP) Timer Registers

GP timer control register (GPTCON)

Figure A–50. GP Timer Control Register (GPTCON) — Address 7400h

15	14	13	12–11	10–9	8–7	
T3STAT	T2STAT	T1STAT	T3TOADC	T2TOADC	T1TOADC	
R–1	R–1	R–1	RW–0	RW–0	RW–0	
6		5–4		3–2		1–0
TCOMPOE		T3PIN		T2PIN		T1PIN
RW–0		RW–0		RW–0		RW–0

Note: R = read access, W = write access, –0 = value after reset

GP timer 1 registers (T1CNT, T1CMPR, T1PR, and T1CON)

Figure A–51. GP Timer 1 Counter Register (T1CNT) — Address 7401h

15	14	13	12	11	10	9	8
D15	D14	D13	D12	D11	D10	D9	D8
RW–0	RW–0	RW–0	RW–0	RW–0	RW–0	RW–0	RW–0
7	6	5	4	3	2	1	0
D7	D6	D5	D4	D3	D2	D1	D0
RW–0	RW–0	RW–0	RW–0	RW–0	RW–0	RW–0	RW–0

Note: R = read access, W = write access, –0 = value after reset

Figure A–52. GP Timer 1 Compare Register (T1CMPR) — Address 7402h

15	14	13	12	11	10	9	8
D15	D14	D13	D12	D11	D10	D9	D8
RW–0	RW–0	RW–0	RW–0	RW–0	RW–0	RW–0	RW–0
7	6	5	4	3	2	1	0
D7	D6	D5	D4	D3	D2	D1	D0
RW–0	RW–0	RW–0	RW–0	RW–0	RW–0	RW–0	RW–0

Note: R = read access, W = write access, –0 = value after reset

Figure A–53. GP Timer 1 Period Register (T1PR) — Address 7403h

15	14	13	12	11	10	9	8
D15	D14	D13	D12	D11	D10	D9	D8
RW–0	RW–0	RW–0	RW–0	RW–0	RW–0	RW–0	RW–0
7	6	5	4	3	2	1	0
D7	D6	D5	D4	D3	D2	D1	D0
RW–0	RW–0	RW–0	RW–0	RW–0	RW–0	RW–0	RW–0

Note: R = read access, W = write access, –0 = value after reset

Figure A–54. GP Timer 1 Control Register (T1CON) — Address 7404h

15	14	13	12	11	10	9	8
Free	Soft	TMODE2	TMODE1	TMODE0	TPS2	TPS1	TPS0
RW–0	RW–0	RW–0	RW–0	RW–0	RW–0	RW–0	RW–0
7	6	5	4	3	2	1	0
TSWT1	TENABLE	TCLKS1	TCLKS0	TCLD1	TCLD0	TECMPR	SELT1PR
RW–0	RW–0	RW–0	RW–0	RW–0	RW–0	RW–0	RW–0

Note: R = read access, W = write access, –0 = value after reset

GP timer 2 registers (T2CNT, T2CMPR, T2PR, and T2CON)*Figure A–55. GP Timer 2 Counter Register (T2CNT) — Address 7405h*

15	14	13	12	11	10	9	8
D15	D14	D13	D12	D11	D10	D9	D8
RW–0	RW–0	RW–0	RW–0	RW–0	RW–0	RW–0	RW–0
7	6	5	4	3	2	1	0
D7	D6	D5	D4	D3	D2	D1	D0
RW–0	RW–0	RW–0	RW–0	RW–0	RW–0	RW–0	RW–0

Note: R = read access, W = write access, –0 = value after reset

Figure A–56. GP Timer 2 Compare Register (T2CMPR) — Address 7406h

15	14	13	12	11	10	9	8
D15	D14	D13	D12	D11	D10	D9	D8
RW–0	RW–0	RW–0	RW–0	RW–0	RW–0	RW–0	RW–0
7	6	5	4	3	2	1	0
D7	D6	D5	D4	D3	D2	D1	D0
RW–0	RW–0	RW–0	RW–0	RW–0	RW–0	RW–0	RW–0

Note: R = read access, W = write access, –0 = value after reset

Figure A–57. GP Timer 2 Period Register (T2PR) — Address 7407h

15	14	13	12	11	10	9	8
D15	D14	D13	D12	D11	D10	D9	D8
RW–0	RW–0	RW–0	RW–0	RW–0	RW–0	RW–0	RW–0
7	6	5	4	3	2	1	0
D7	D6	D5	D4	D3	D2	D1	D0
RW–0	RW–0	RW–0	RW–0	RW–0	RW–0	RW–0	RW–0

Note: R = read access, W = write access, –0 = value after reset

Figure A–58. GP Timer 2 Control Register (T2CON) — Address 7408h

15	14	13	12	11	10	9	8
Free	Soft	TMODE2	TMODE1	TMODE0	TPS2	TPS1	TPS0
RW–0	RW–0	RW–0	RW–0	RW–0	RW–0	RW–0	RW–0
7	6	5	4	3	2	1	0
TSWT1	TENABLE	TCLKS1	TCLKS0	TCLD1	TCLD0	TECMPR	SELT1PR
RW–0	RW–0	RW–0	RW–0	RW–0	RW–0	RW–0	RW–0

Note: R = read access, W = write access, –0 = value after reset

GP timer 3 registers (T3CNT, T3CMPR, T3PR, and T3CON)

Figure A–59. GP Timer 3 Counter Register (T3CNT) — Address 7409h

15	14	13	12	11	10	9	8
D15	D14	D13	D12	D11	D10	D9	D8
RW–0	RW–0	RW–0	RW–0	RW–0	RW–0	RW–0	RW–0
7	6	5	4	3	2	1	0
D7	D6	D5	D4	D3	D2	D1	D0
RW–0	RW–0	RW–0	RW–0	RW–0	RW–0	RW–0	RW–0

Note: R = read access, W = write access, –0 = value after reset

Figure A–60. GP Timer 3 Compare Register (T3CMPR) — Address 740Ah

15	14	13	12	11	10	9	8
D15	D14	D13	D12	D11	D10	D9	D8
RW–0	RW–0	RW–0	RW–0	RW–0	RW–0	RW–0	RW–0
7	6	5	4	3	2	1	0
D7	D6	D5	D4	D3	D2	D1	D0
RW–0	RW–0	RW–0	RW–0	RW–0	RW–0	RW–0	RW–0

Note: R = read access, W = write access, –0 = value after reset

Figure A–61. GP Timer 3 Period Register (T3PR) — Address 740Bh

15	14	13	12	11	10	9	8
D15	D14	D13	D12	D11	D10	D9	D8
RW–0	RW–0	RW–0	RW–0	RW–0	RW–0	RW–0	RW–0
7	6	5	4	3	2	1	0
D7	D6	D5	D4	D3	D2	D1	D0
RW–0	RW–0	RW–0	RW–0	RW–0	RW–0	RW–0	RW–0

Note: R = read access, W = write access, –0 = value after reset

Figure A–62. GP Timer 3 Control Register (T3CON) — Address 740Ch

15	14	13	12	11	10	9	8
Free	Soft	TMODE2	TMODE1	TMODE0	TPS2	TPS1	TPS0
RW–0	RW–0	RW–0	RW–0	RW–0	RW–0	RW–0	RW–0
7	6	5	4	3	2	1	0
TSWT1	TENABLE	TCLKS1	TCLKS0	TCLD1	TCLD0	TECMPR	SELT1PR
RW–0	RW–0	RW–0	RW–0	RW–0	RW–0	RW–0	RW–0

Note: R = read access, W = write access, –0 = value after reset

A.10 Compare Unit Registers

Compare control register (COMCON)

Figure A–63. Compare Control Register (COMCON) — Address 7411h

15	14	13	12	11	10	9	8
CENABLE	CLD1	CLD0	SVENABLE	ACTRLD1	ACTRLD0	FCOMPOE	SCOMPOE
RW-0	RW-0	RW-0	RW-0	RW-0	RW-0	RW-0	RW-0
7	6	5	4	3	2	1	0
SELTMR	SCLD1	SCLD0	SACTRLD1	SACTRLD0	SELCMP3	SELCMP2	SELCMP1
RW-0	RW-0	RW-0	RW-0	RW-0	RW-0	RW-0	RW-0

Note: R = read access, W = write access, -0 = value after reset

Full-compare action control register (ACTR)

Figure A–64. Full-Compare Action Control Register (ACTR) — Address 7413h

15	14	13	12	11	10	9	8
SVRDIR	D2	D1	D0	CMP6ACT1	CMP6ACT0	CMP5ACT1	CMP5ACT0
RW-0	RW-0	RW-0	RW-0	RW-0	RW-0	RW-0	RW-0
7	6	5	4	3	2	1	0
CMP4ACT1	CMP4ACT0	CMP3ACT1	CMP3ACT0	CMP2ACT1	CMP2ACT0	CMP1ACT1	CMP1ACT0
RW-0	RW-0	RW-0	RW-0	RW-0	RW-0	RW-0	RW-0

Note: R = read access, W = write access, -0 = value after reset

Full-compare unit compare registers (CMPR1, CMPR2, and CMPR3)*Figure A–65. Full-Compare Unit Compare Register 1 (CMPR1) — Address 7417h*

15	14	13	12	11	10	9	8
D15	D14	D13	D12	D11	D10	D9	D8
RW–0	RW–0	RW–0	RW–0	RW–0	RW–0	RW–0	RW–0
7	6	5	4	3	2	1	0
D7	D6	D5	D4	D3	D2	D1	D0
RW–0	RW–0	RW–0	RW–0	RW–0	RW–0	RW–0	RW–0

Note: R = read access, W = write access, –0 = value after reset

Figure A–66. Full-Compare Unit Compare Register 2 (CMPR2) — Address 7418h

15	14	13	12	11	10	9	8
D15	D14	D13	D12	D11	D10	D9	D8
RW–0	RW–0	RW–0	RW–0	RW–0	RW–0	RW–0	RW–0
7	6	5	4	3	2	1	0
D7	D6	D5	D4	D3	D2	D1	D0
RW–0	RW–0	RW–0	RW–0	RW–0	RW–0	RW–0	RW–0

Note: R = read access, W = write access, –0 = value after reset

Figure A–67. Full-Compare Unit Compare Register 3 (CMPR3) — Address 7419h

15	14	13	12	11	10	9	8
D15	D14	D13	D12	D11	D10	D9	D8
RW–0	RW–0	RW–0	RW–0	RW–0	RW–0	RW–0	RW–0
7	6	5	4	3	2	1	0
D7	D6	D5	D4	D3	D2	D1	D0
RW–0	RW–0	RW–0	RW–0	RW–0	RW–0	RW–0	RW–0

Note: R = read access, W = write access, –0 = value after reset

Simple-compare action control register (SACTR)

Figure A–68. Simple-Compare Action Control Register (SACTR) — Address 7414h

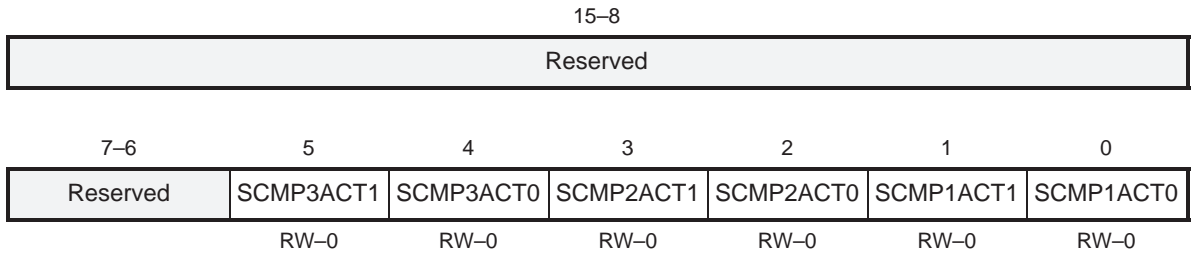

Note: R = read access, W = write access, –0 = value after reset

Simple-compare unit compare registers (SCMPR1, SCMPR2, and SCMPR3)

Figure A–69. Simple-Compare Unit Compare Register 1 (SCMPR1) — Address 741Ah

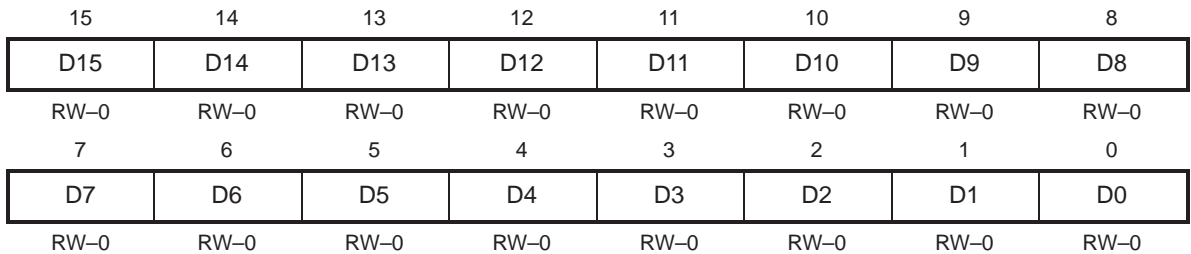

Note: R = read access, W = write access, –0 = value after reset

Figure A–70. Simple-Compare Unit Compare Register 2 (SCMPR2) — Address 741Bh

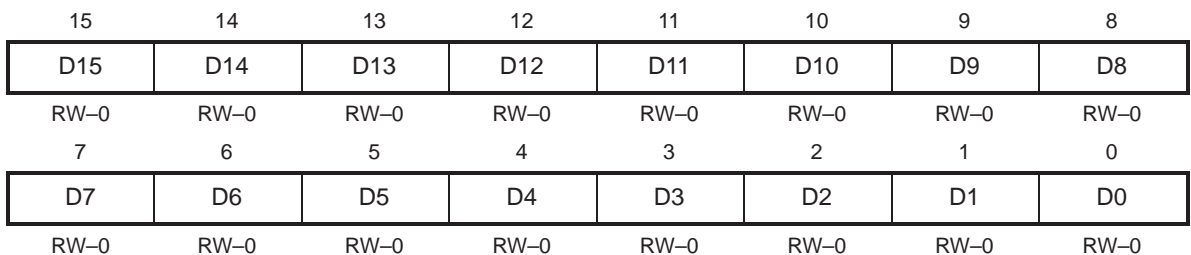

Note: R = read access, W = write access, –0 = value after reset

Figure A-71. Simple-Compare Unit Compare Register 3 (SCMPR3) — Address 741Ch

15	14	13	12	11	10	9	8
D15	D14	D13	D12	D11	D10	D9	D8
RW-0	RW-0	RW-0	RW-0	RW-0	RW-0	RW-0	RW-0
7	6	5	4	3	2	1	0
D7	D6	D5	D4	D3	D2	D1	D0
RW-0	RW-0	RW-0	RW-0	RW-0	RW-0	RW-0	RW-0

Note: R = read access, W = write access, -0 = value after reset

A.11 Capture Unit Registers

Capture control register (CAPCON)

Figure A–72. Capture Control Register (CAPCON) — Address 7420h

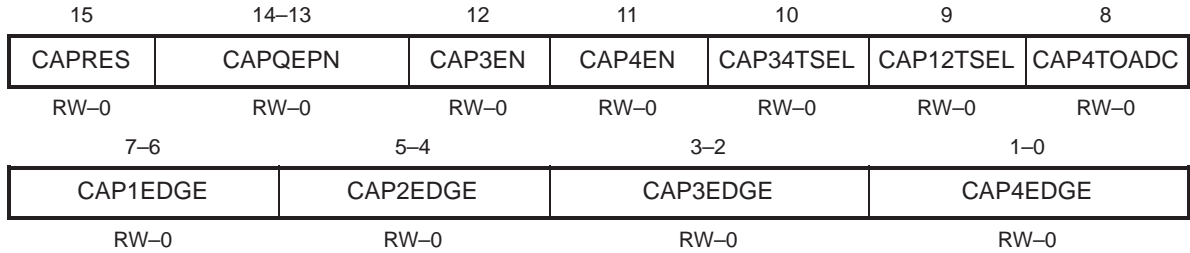

Note: R = read access, W = write access, –0 = value after reset

Capture FIFO status register (CAPFIFO)

Figure A–73. Capture FIFO Status Register (CAPFIFO) — Address 7422h

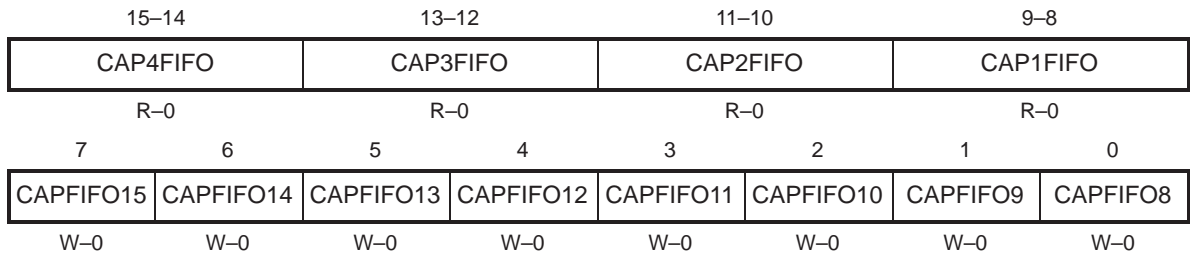

Note: R = read access, W = write access, –0 = value after reset

Two-level-deep capture FIFO stack registers (CAP1FIFO, CAP2FIFO, CAP3FIFO, and CAP4FIFO)

Figure A–74. Capture 1 FIFO Stack Register (CAP1FIFO) — Address 7423h

15	14	13	12	11	10	9	8
D15	D14	D13	D12	D11	D10	D9	D8
RW–0	RW–0	RW–0	RW–0	RW–0	RW–0	RW–0	RW–0
7	6	5	4	3	2	1	0
D7	D6	D5	D4	D3	D2	D1	D0
RW–0	RW–0	RW–0	RW–0	RW–0	RW–0	RW–0	RW–0

Note: R = read access, W = write access, –0 = value after reset

Figure A–75. Capture 2 FIFO Stack Register (CAP2FIFO) — Address 7424h

15	14	13	12	11	10	9	8
D15	D14	D13	D12	D11	D10	D9	D8
RW–0	RW–0	RW–0	RW–0	RW–0	RW–0	RW–0	RW–0
7	6	5	4	3	2	1	0
D7	D6	D5	D4	D3	D2	D1	D0
RW–0	RW–0	RW–0	RW–0	RW–0	RW–0	RW–0	RW–0

Note: R = read access, W = write access, –0 = value after reset

Figure A–76. Capture 3 FIFO Stack Register (CAP3FIFO) — Address 7425h

15	14	13	12	11	10	9	8
D15	D14	D13	D12	D11	D10	D9	D8
RW–0	RW–0	RW–0	RW–0	RW–0	RW–0	RW–0	RW–0
7	6	5	4	3	2	1	0
D7	D6	D5	D4	D3	D2	D1	D0
RW–0	RW–0	RW–0	RW–0	RW–0	RW–0	RW–0	RW–0

Note: R = read access, W = write access, –0 = value after reset

Figure A-77. Capture 4 FIFO Stack Register (CAP4FIFO) — Address 7426h

15	14	13	12	11	10	9	8
D15	D14	D13	D12	D11	D10	D9	D8
RW-0	RW-0	RW-0	RW-0	RW-0	RW-0	RW-0	RW-0
7	6	5	4	3	2	1	0
D7	D6	D5	D4	D3	D2	D1	D0
RW-0	RW-0	RW-0	RW-0	RW-0	RW-0	RW-0	RW-0

Note: R = read access, W = write access, -0 = value after reset

A.12 Dead-Band Timer Control Register

Figure A–78. Dead-Band Timer Control Register (DBTCON) — Address 7415h

15	14	13	12	11	10	9	8
DBT7	DBT6	DBT5	DBT4	DBT3	DBT2	DBT1	DBT0
RW–0	RW–0	RW–0	RW–0	RW–0	RW–0	RW–0	RW–0
7	6	5	4	3	2–0		
EDBT3	EDBT2	EDBT1	DBTPS1	DBTPS0	Reserved		
RW–0	RW–0	RW–0	RW–0	RW–0			

Note: R = read access, W = write access, –0 = value after reset

A.13 Event Manager (EV) Interrupt Registers

EV interrupt mask registers (EVIMRA, EVIMRB, and EVIMRC)

Figure A–79. EV Interrupt Mask Register A (EVIMRA) — Address 742Ch

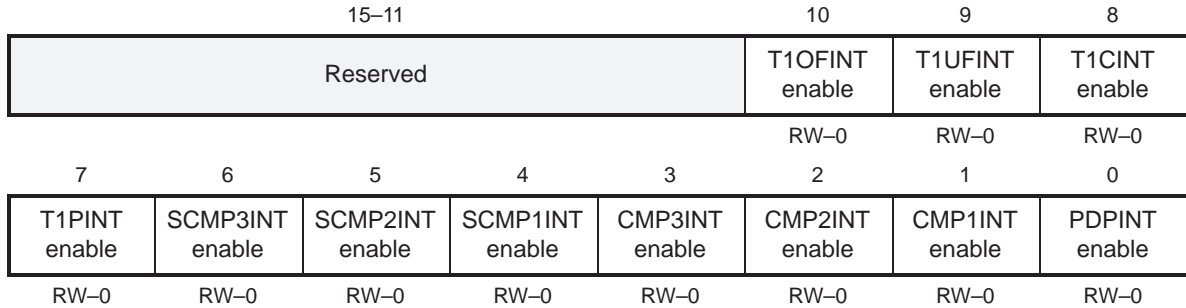

Note: R = read access, W = write access, –0 = value after reset

Figure A–80. EV Interrupt Mask Register B (EVIMRB) — Address 742Dh

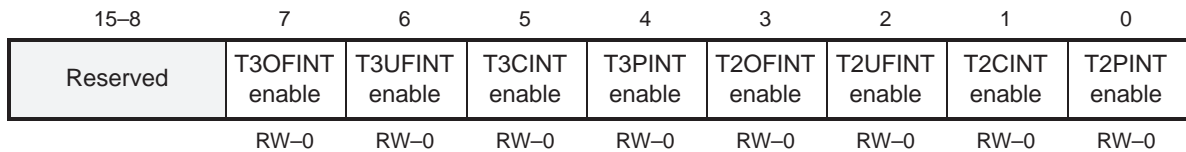

Note: R = read access, W = write access, –0 = value after reset

Figure A–81. EV Interrupt Mask Register C (EVIMRC) — Address 742Eh



Note: R = read access, W = write access, –0 = value after reset

EV Interrupt flag registers (EVIFRA, EVIFRB, and EVIFRC)*Figure A–82. EV Interrupt Flag Register A (EVIFRA) — Address 742Fh*

15–11					10	9	8
Reserved					T1OFINT flag	T1UFINT flag	T1CINT flag
					RW–0	RW–0	RW–0
7	6	5	4	3	2	1	0
T1PINT flag	SCMP3INT flag	SCMP2INT flag	SCMP1INT flag	CMP3INT flag	CMP2INT flag	CMP1INT flag	PDPINT flag
RW–0	RW–0	RW–0	RW–0	RW–0	RW–0	RW–0	RW–0

Note: R = read access, W = write access, –0 = value after reset

Figure A–83. EV Interrupt Flag Register B (EVIFRB) — Address 7430h

15–8	7	6	5	4	3	2	1	0
Reserved	T3OFINT flag	T3UFINT flag	T3CINT flag	T3PINT flag	T2OFINT flag	T2UFINT flag	T2CINT flag	T2PINT flag
	RW–0	RW–0	RW–0	RW–0	RW–0	RW–0	RW–0	RW–0

Note: R = read access, W = write access, –0 = value after reset

Figure A–84. EV Interrupt Flag Register C (EVIFRC) — Address 7431h

15–4	3	2	1	0
Reserved	CAP4INT flag	CAP3INT flag	CAP2INT flag	CAP1INT flag
	RW–0	RW–0	RW–0	RW–0

Note: R = read access, W = write access, –0 = value after reset

EV interrupt vector registers (EVIVRA, EVIVRB, and EVIVRC)

Figure A–85. EV Interrupt Vector Register A (EVIVRA) — Address 7432h

15	14	13	12	11	10	9	8	7	6	5	4	3	2	1	0
0	0	0	0	0	0	0	0	0	0	D5	D4	D3	D2	D1	D0
R–0	R–0	R–0	R–0	R–0	R–0	R–0	R–0	R–0	R–0	R–0	R–0	R–0	R–0	R–0	R–0

Note: R = read access, W = write access, –0 = value after reset

Figure A–86. EV Interrupt Vector Register B (EVIVRB) — Address 7433h

15	14	13	12	11	10	9	8	7	6	5	4	3	2	1	0
0	0	0	0	0	0	0	0	0	0	D5	D4	D3	D2	D1	D0
R–0	R–0	R–0	R–0	R–0	R–0	R–0	R–0	R–0	R–0	R–0	R–0	R–0	R–0	R–0	R–0

Note: R = read access, W = write access, –0 = value after reset

Figure A–87. EV Interrupt Vector Register C (EVIVRC) — Address 7434h

15	14	13	12	11	10	9	8	7	6	5	4	3	2	1	0
0	0	0	0	0	0	0	0	0	0	D5	D4	D3	D2	D1	D0
R–0	R–0	R–0	R–0	R–0	R–0	R–0	R–0	R–0	R–0	R–0	R–0	R–0	R–0	R–0	R–0

Note: R = read access, W = write access, –0 = value after reset

A.14 Flash Control Mode Register—Including Flash Segment Control Register

Flash control mode register (FCMR)

Writing a dummy value to this register using the OUT instruction selects the REGISTER mode for the Flash. Reading from this address using the IN instruction selects the ARRAY mode for the Flash.

(Note: The Flash Segment Control Register (SEG_CTR) is only visible in the Flash REGISTER mode.)

Figure A–88. Flash Control Mode Register (FCMR) — I/O Space Address FF0Fh

15	14	13	12	11	10	9	8	7	6	5	4	3	2	1	0
x	x	x	x	x	x	x	x	x	x	x	x	x	x	x	x
RW–x															

Note: R = read access, W = write access, –n = value after reset (x = indeterminate)

Flash segment control register (SEG_CTR)

For more details on using this register for Flash programming, see *TMS320F20x/F24x DSP Embedded Flash Memory Technical Reference* (literature number SPRU282).

Figure A–89. Segment Control Register (SEG_CTR) — Program Space Address 0h

15–8	7	6	5	4	3	2–1	0
SEG7–0	Reserved	KEY1	KEY0	VER1	VER0	Write/erase	EXE
RW–0		RW–0	RW–0	RW–0	RW–0	RW–0	RW–0

Note: R = read access, W = write access, –0 = value after reset

A.15 Wait-State Generator Control Register

Figure A-90. Wait-State Generator Control Register (WSGR) — I/O Space
Address FFFFh

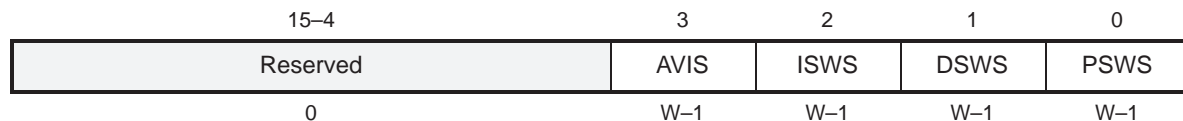

Note: R = read access, W = write access, -0 = value after reset

Glossary

A

A0–A15: Collectively, the external address bus; the 16 pins are used in parallel to address external data memory, program memory, or I/O space.

ACC: See *accumulator*.

ACCH: *Accumulator high word*. The upper 16 bits of the accumulator. See also *accumulator*.

ACCL: *Accumulator low word*. The lower 16 bits of the accumulator. See also *accumulator*.

accumulator: A 32-bit register that stores the results of operations in the central arithmetic logic unit (CALU) and provides an input for subsequent CALU operations. The accumulator also performs shift and rotate operations.

address: The location of program code or data stored in memory.

addressing mode: A method by which an instruction interprets its operands to acquire the data it needs. See also *direct addressing*; *immediate addressing*; *indirect addressing*.

analog-to-digital (A/D) converter: A circuit that translates an analog signal to a digital signal.

AR: See *auxiliary register*.

AR0–AR7: *Auxiliary registers 0 through 7*. See *auxiliary register*.

ARAU: See *auxiliary register arithmetic unit (ARAU)*.

ARB: See *auxiliary register pointer buffer (ARB)*.

ARP: See *auxiliary register pointer (ARP)*.

auxiliary register: One of eight 16-bit registers (AR7–AR0) used as pointers to addresses in data space. The registers are operated on by the auxiliary register arithmetic unit (ARAU) and are selected by the auxiliary register pointer (ARP).

auxiliary register arithmetic unit (ARAU): A 16-bit arithmetic unit used to increment, decrement, or compare the contents of the auxiliary registers. Its primary function is manipulating auxiliary register values for indirect addressing.

auxiliary register pointer (ARP): A 3-bit field in status register ST0 that points to the current auxiliary register.

auxiliary register pointer buffer (ARB): A 3-bit field in status register ST1 that holds the previous value of the auxiliary register pointer (ARP).

B

B0: An on-chip block of dual-access RAM that can be configured as either data memory or program memory, depending on the value of the CNF bit in status register ST1.

B1: An on-chip block of dual-access RAM available for data memory.

B2: An on-chip block of dual-access RAM available for data memory.

$\overline{\text{BIO}}$ pin: A general-purpose input pin that can be tested by conditional instructions that cause a branch when an external device drives $\overline{\text{BIO}}$ low.

bit-reversed indexed addressing: A method of indirect addressing that allows efficient I/O operations by resequencing the data points in a radix-2 fast Fourier transform (FFT) program. The direction of carry propagation in the ARAU is reversed.

boot loader: A built-in segment of code that transfers code from an external source to a 16-bit external program destination at reset.

$\overline{\text{BR}}$: *Bus request pin.* This pin is tied to the $\overline{\text{BR}}$ signal, which is asserted when a global data memory access is initiated.

branch: A switching of program control to a nonsequential program-memory address.

C

C bit: See *carry bit*.

CALU: See *central arithmetic logic unit (CALU)*.

carry bit: Bit 9 of status register ST1; used by the CALU for extended arithmetic operations and accumulator shifts and rotates. The carry bit can be tested by conditional instructions.

central arithmetic logic unit (CALU): The 32-bit wide main arithmetic logic unit for the 'C24x CPU that performs arithmetic and logic operations. It accepts 32-bit values for operations, and its 32-bit output is held in the accumulator.

CLKIN: *Input clock signal.* A clock source signal supplied to the on-chip clock generator at the CLKIN/X2 pin or generated internally by the on-chip oscillator. The clock generator divides or multiplies CLKIN to produce the CPU clock signal, CLKOUT1.

CLKOUT: *Master clock output signal.* The output signal of the on-chip clock generator. The CLKOUT1 high pulse signifies the CPU's logic phase (when internal values are changed), and the CLKOUT1 low pulse signifies the CPU's latch phase (when the values are held constant).

clock mode (clock generator): One of the modes which sets the internal CPU clock frequency to a fraction or multiple of the frequency of the input clock signal CLKIN.

CNF bit: *DARAM configuration bit.* Bit 12 in status register ST1. CNF is used to determine whether the on-chip RAM block B0 is mapped to program space or data space.

codec: A device that codes in one direction of transmission and decodes in another direction of transmission.

COFF: *Common object file format.* A system of files configured according to a standard developed by AT&T. These files are relocatable in memory space.

context saving/restoring: Saving the system status when the device enters a subroutine (such as an interrupt service routine) and restoring the system status when exiting the subroutine. On the 'C24x, only the program counter value is saved and restored automatically; other context saving and restoring must be performed by the subroutine.

CPU: *Central processing unit.* The 'C24x CPU is the portion of the processor involved in arithmetic, shifting, and Boolean logic operations, as well as the generation of data- and program-memory addresses. The CPU includes the central arithmetic logic unit (CALU), the multiplier, and the auxiliary register arithmetic unit (ARAU).

CPU cycle: The time required for the CPU to go through one logic phase (during which internal values are changed) and one latch phase (during which the values are held constant).

current AR: See *current auxiliary register*.

current auxiliary register: The auxiliary register pointed to by the auxiliary register pointer (ARP). The auxiliary registers are AR0 (ARP = 0) through AR7 (ARP = 7). See also *auxiliary register*, *next auxiliary register*.

current data page: The data page indicated by the content of the data page pointer (DP). See also *data page*; *DP*.

D

D0–D15: Collectively, the external data bus; the 16 pins are used in parallel to transfer data between the 'C24x and external data memory, program memory, or I/O space.

DARAM: *Dual-access RAM.* RAM that can be accessed twice in a single CPU clock cycle. For example, your code can read from and write to DARAM in the same clock cycle.

DARAM configuration bit (CNF): See *CNF bit*.

data-address generation logic: Logic circuitry that generates the addresses for data memory reads and writes. This circuitry, which includes the auxiliary registers and the ARAU, can generate one address per machine cycle. See also *program-address generation logic*.

data page: One block of 128 words in data memory. Data memory contains 512 data pages. Data page 0 is the first page of data memory (addresses 0000h–007Fh); data page 511 is the last page (addresses FF80h–FFFFh). See also *data page pointer (DP)*; *direct addressing*.

data page 0: Addresses 0000h–007Fh in data memory; contains the memory-mapped registers, a reserved test/emulation area for special information transfers, and the scratch-pad RAM block (B2).

data page pointer (DP): A 9-bit field in status register ST0 that specifies which of the 512 data pages is currently selected for direct address generation. When an instruction uses direct addressing to access a data-memory value, the DP provides the nine MSBs of the data-memory address, and the instruction provides the seven LSBs.

data-read address bus (DRAB): A 16-bit internal bus that carries the address for each read from data memory.

data read bus (DRDB): A 16-bit internal bus that carries data from data memory to the CALU and the ARAU.

data-write address bus (DWAB): A 16-bit internal bus that carries the address for each write to data memory.

data write bus (DWEB): A 16-bit internal bus that carries data to both program memory and data memory.

decode phase: The phase of the pipeline in which the instruction is decoded. See also *pipeline*; *instruction-fetch phase*; *operand-fetch phase*; *instruction-execute phase*.

direct addressing: One of the methods used by an instruction to address data-memory. In direct addressing, the data-page pointer (DP) holds the nine MSBs of the address (the current data page), and the instruction word provides the seven LSBs of the address (the offset). See also *indirect addressing*.

DP: See *data page pointer (DP)*.

DRAB: See *data-read address bus (DRAB)*.

DRDB: See *data read bus (DRDB)*.

\overline{DS} : *Data memory select pin.* The 'C24x asserts \overline{DS} to indicate an access to external data memory (local or global).

DSWS: *Data-space wait-state bit(s).* A value in the wait-state generator control register (WSGR) that determines the number of wait states applied to reads from and writes to off-chip data space.

dual-access RAM: See *DARAM*.

dummy cycle: A CPU cycle in which the CPU intentionally reloads the program counter with the same address.

DWAB: See *data-write address bus (DWAB)*.

DWEB: See *data write bus (DWEB)*.

E

execute phase: The fourth phase of the pipeline; the phase in which the instruction is executed. See also *pipeline*; *instruction-fetch phase*; *instruction-decode phase*; *operand-fetch phase*.

external interrupt: A hardware interrupt triggered by an external event sending an input through an interrupt pin.

F

FIFO buffer: *First-in, first-out buffer.* A portion of memory in which data is stored and then retrieved in the same order in which it was stored. The synchronous serial port has two four-word-deep FIFO buffers: one for its transmit operation and one for its receive operation.

flash memory: Electronically erasable and programmable, nonvolatile (read-only) memory.

G

general-purpose input/output pins: Pins that can be used to accept input signals or send output signals. These pins are the input pin $\overline{\text{BIO}}$, the output pin XF, and the GPIO pins.

global data space: One of the four 'C24x address spaces. The global data space can be used to share data with other processors within a system and can serve as additional data space. See also *local data space*.

GREG: *Global memory allocation register.* A memory-mapped register used for specifying the size of the global data memory. Addresses not allocated by the GREG for global data memory are available for local data memory.

H

hardware interrupt: An interrupt triggered through physical connections with on-chip peripherals or external devices.

I

immediate addressing: One of the methods for obtaining data values used by an instruction; the data value is a constant embedded directly into the instruction word; data memory is not accessed.

immediate operand/immediate value: A constant given as an operand in an instruction that is using immediate addressing.

IMR: See *interrupt mask register (IMR)*.

indirect addressing: One of the methods for obtaining data values used by an instruction. When an instruction uses indirect addressing, data memory is addressed by the current auxiliary register. See also *direct addressing*.

input clock signal: See *CLKIN*.

input shifter: A 16- to 32-bit left barrel shifter that shifts incoming 16-bit data from 0 to 16 positions left relative to the 32-bit output.

instruction-decode phase: The second phase of the pipeline; the phase in which the instruction is decoded. See also *pipeline; instruction-fetch phase; operand-fetch phase; instruction-execute phase*.

instruction-execute phase: The fourth phase of the pipeline; the phase in which the instruction is executed. See also *pipeline; instruction-fetch phase; instruction-decode phase; operand-fetch phase*.

instruction-fetch phase: The first phase of the pipeline; the phase in which the instruction is fetched from program-memory. See also *pipeline; instruction-decode phase; operand-fetch phase; instruction-execute phase*.

instruction register (IR): A 16-bit register that contains the instruction being executed.

instruction word: A 16-bit value representing all or half of an instruction. An instruction that is fully represented by 16 bits uses one instruction word. An instruction that must be represented by 32 bits uses two instruction words (the second word is a constant).

internal interrupt: A hardware interrupt caused by an on-chip peripheral.

interrupt: A signal sent to the CPU that (when not masked or disabled) forces the CPU into a subroutine called an interrupt service routine (ISR). This signal can be triggered by an external device, an on-chip peripheral, or an instruction (INTR, NMI, or TRAP).

- interrupt acknowledge signal ($\overline{\text{IACK}}$):** A signal that indicates an interrupt has been received and that the program counter is fetching the interrupt vector that will force the processor into the appropriate interrupt service routine.
- interrupt flag register (IFR):** A 16-bit memory-mapped register that indicates pending interrupts. Read the IFR to identify pending interrupts and write to the IFR to clear selected interrupts. Writing a 1 to any IFR flag bit clears that bit to 0.
- interrupt latency:** The delay between the time an interrupt request is made and the time it is serviced.
- interrupt mask register (IMR):** A 16-bit memory-mapped register used to mask external and internal interrupts. Writing a 1 to any IMR bit position enables the corresponding interrupt (when $\text{INTM} = 0$).
- interrupt mode bit (INTM):** Bit 9 in status register ST0; either enables all maskable interrupts that are not masked by the IMR or disables all maskable interrupts.
- interrupt service routine (ISR):** A module of code that is executed in response to a hardware or software interrupt.
- interrupt trap:** See *interrupt service routine (ISR)*.
- interrupt vector:** A branch instruction that leads the CPU to an interrupt service routine (ISR).
- interrupt vector location:** An address in program memory where an interrupt vector resides. When an interrupt is acknowledged, the CPU branches to the interrupt vector location and fetches the interrupt vector.
- INTM bit:** See *interrupt mode bit (INTM)*.
- I/O-mapped register:** One of the on-chip registers mapped to addresses in I/O (input/output) space. These registers, which include the registers for the on-chip peripherals, must be accessed with the IN and OUT instructions. See also *memory-mapped register*.
- IR:** See *instruction register (IR)*.
- $\overline{\text{IS}}$:** *I/O space select pin.* The 'C24x asserts $\overline{\text{IS}}$ to indicate an access to external I/O space.
- ISR:** See *interrupt service routine (ISR)*.
- ISWS:** *I/O-space wait-state bit(s).* A value in the wait-state generator control register (WSGR) that determines the number of wait states applied to reads from and writes to off-chip I/O space.

L

latch phase: The phase of a CPU cycle during which internal values are held constant. See also *logic phase*; *CLKOUT1*.

local data space: The portion of data-memory addresses that are not allocated as global by the global memory allocation register (GREG). If none of the data-memory addresses are allocated for global use, all of data space is local. See also *global data space*.

logic phase: The phase of a CPU cycle during which internal values are changed. See also *latch phase*; *CLKOUT1*.

long-immediate value: A 16-bit constant given as an operand of an instruction that is using immediate addressing.

LSB: *Least significant bit*. The lowest order bit in a word. When used in plural form (LSBs), refers to a specified number of low-order bits, beginning with the lowest order bit and counting to the left. For example, the four LSBs of a 16-bit value are bits 0 through 3. See also *MSB*.

M

machine cycle: See *CPU cycle*.

maskable interrupt: A hardware interrupt that can be enabled or disabled through software. See also *nonmaskable interrupt*.

master clock output signal: See *CLKOUT1*.

master phase: See *logic phase*.

memory-mapped register: One of the on-chip registers mapped to addresses in data memory. See also *I/O-mapped register*.

microcomputer mode: A mode in which the on-chip ROM or flash memory is enabled. This mode is selected with the $\overline{MP/MC}$ pin. See also *MP/MC pin*; *microprocessor mode*.

microprocessor mode: A mode in which the on-chip ROM or flash memory is disabled. This mode is selected with the $\overline{MP/MC}$ pin. See also *MP/MC pin*; *microcomputer mode*.

microstack (MSTACK): A register used for temporary storage of the program counter (PC) value when an instruction needs to use the PC to address a second operand.

MIPS: Million instructions per second.

MP/ \overline{MC} pin: A pin that indicates whether the processor is operating in microprocessor mode or microcomputer mode. MP/ \overline{MC} high selects microprocessor mode; MP/ \overline{MC} low selects microcomputer mode.

MSB: *Most significant bit.* The highest order bit in a word. When used in plural form (MSBs), refers to a specified number of high-order bits, beginning with the highest order bit and counting to the right. For example, the eight MSBs of a 16-bit value are bits 15 through 8. See also *LSB*.

MSTACK: See *microstack*.

multiplier: A part of the CPU that performs 16-bit \times 16-bit multiplication and generates a 32-bit product. The multiplier operates using either signed or unsigned 2s-complement arithmetic.

N

next AR: See *next auxiliary register*.

next auxiliary register: The register that is pointed to by the auxiliary register pointer (ARP) when an instruction that modifies ARP is finished executing. See also *auxiliary register*, *current auxiliary register*.

\overline{NMI} : A hardware interrupt that uses the same logic as the maskable interrupts but cannot be masked. It is often used as a soft reset. See also *maskable interrupt*, *nonmaskable interrupt*.

nonmaskable interrupt: An interrupt that can be neither masked by the interrupt mask register (IMR) nor disabled by the INTM bit of status register ST0.

NPAR: *Next program address register.* Part of the program-address generation logic. This register provides the address of the next instruction to the program counter (PC), the program address register (PAR), the micro stack (MSTACK), or the stack.

O

operand: A value to be used or manipulated by an instruction; specified in the instruction.

operand-fetch phase: The third phase of the pipeline; the phase in which an operand or operands are fetched from memory. See also *pipeline*; *instruction-fetch phase*; *instruction-decode phase*; *instruction-execute phase*.

output shifter: 32- to 16-bit barrel left shifter. Shifts the 32-bit accumulator output from 0 to 7 bits left for quantization management, and outputs either the 16-bit high or low half of the shifted 32-bit data to the data write bus (DWEB).

OV bit: *Overflow flag bit.* Bit 12 of status register ST0; indicates whether the result of an arithmetic operation has exceeded the capacity of the accumulator.

overflow (in a register): A condition in which the result of an arithmetic operation exceeds the capacity of the register used to hold that result.

overflow mode: The mode in which an overflow in the accumulator causes the accumulator to be loaded with a preset value. If the overflow is in the positive direction, the accumulator is loaded with its most positive number. If the overflow is in the negative direction, the accumulator is filled with its most negative number.

OVM bit: *Overflow mode bit.* Bit 11 of status register ST0; enables or disables overflow mode. See also *overflow mode*.

P

PAB: See *program address bus (PAB)*.

PAR: *Program address register.* A register that holds the address currently being driven on the program address bus for as many cycles as it takes to complete all memory operations scheduled for the current machine cycle.

PC: See *program counter (PC)*.

PCB: *Printed circuit board.*

pending interrupt: A maskable interrupt that has been successfully requested but is awaiting acknowledgement by the CPU.

pipeline: A method of executing instructions in an assembly line fashion. The 'C24x pipeline has four independent phases. During a given CPU cycle, four different instructions can be active, each at a different stage of completion. See also *instruction-fetch phase; instruction-decode phase; operand-fetch phase; instruction-execute phase*.

PLL: Phase lock loop circuit.

PM bits: See *product shift mode bits (PM)*.

power-down mode: The mode in which the processor enters a dormant state and dissipates considerably less power than during normal operation. This mode is initiated by the execution of an IDLE instruction. During a power-down mode, all internal contents are maintained so that operation continues unaltered when the power-down mode is terminated. The contents of all on-chip RAM also remains unchanged.

PRDB: See *program read bus (PRDB)*.

PREG: See *product register (PREG)*.

product register (PREG): A 32-bit register that holds the results of a multiply operation.

product shifter: A 32-bit shifter that performs a 0-, 1-, or 4-bit left shift, or a 6-bit right shift of the multiplier product based on the value of the product shift mode bits (PM).

product shift mode: One of four modes (no-shift, shift-left-by-one, shift-left-by-four, or shift-right-by-six) used by the product shifter.

product shift mode bits (PM): Bits 0 and 1 of status register ST1; they identify which of four shift modes (no-shift, left-shift-by-one, left-shift-by-four, or right-shift-by-six) will be used by the product shifter.

program address bus (PAB): A 16-bit internal bus that provides the addresses for program-memory reads and writes.

program-address generation logic: Logic circuitry that generates the addresses for program memory reads and writes, and an operand address in instructions that require two registers to address operands. This circuitry can generate one address per machine cycle. See also *data-address generation logic*.

program control logic: Logic circuitry that decodes instructions, manages the pipeline, stores status of operations, and decodes conditional operations.

program counter (PC): A register that indicates the location of the next instruction to be executed.

program read bus (PRDB): A 16-bit internal bus that carries instruction code and immediate operands, as well as table information, from program memory to the CPU.

$\overline{\text{PS}}$: *Program select pin.* The 'C24x asserts $\overline{\text{PS}}$ to indicate an access to external program memory.

R

PSLWS: *Lower program-space wait-state bits.* A value in the wait-state generator control register (WSGR) that determines the number of wait states applied to reads from and writes to off-chip lower program space (addresses 0000h–7FFFh). See also *PSUWS*.

PSUWS: *Upper program-space wait-state bits.* A value in the wait-state generator control register (WSGR) that determines the number of wait states applied to reads from and writes to off-chip upper program space (addresses 8000h–FFFFh). See also *PSLWS*.

\overline{RD} : *Read select pin.* The 'C24x asserts \overline{RD} to request a read from external program, data, or I/O space. \overline{RD} can be connected directly to the output enable pin of an external device.

READY: *External device ready pin.* Used to create wait states externally. When this pin is driven low, the 'C24x waits one CPU cycle and then tests READY again. After READY is driven low, the 'C24x does not continue processing until READY is driven high.

repeat counter (RPTC): A 16-bit register that counts the number of times a single instruction is repeated. RPTC is loaded by an RPT instruction.

reset: A way to bring the processor to a known state by setting the registers and control bits to predetermined values and signaling execution to start at address 0000h.

reset pin (\overline{RS}): A pin that causes a reset.

reset vector: The interrupt vector for reset.

return address: The address of the instruction to be executed when the CPU returns from a subroutine or interrupt service routine.

RPTC: See *repeat counter (RPTC)*.

\overline{RS} : *Reset pin.* When driven low, causes a reset on any 'C24x device.

R/\overline{W} : *Read/write pin.* Indicates the direction of transfer between the 'C24x and external program, data, or I/O space.

S

SARAM: *Single-access RAM.* RAM that can be accessed (read from or written to) once in a single CPU cycle.

scratch-pad RAM: Another name for DARAM block B2 in data space (32 words).

short-immediate value: An 8-, 9-, or 13-bit constant given as an operand of an instruction that is using immediate addressing.

sign bit: The MSB of a value when it is seen by the CPU to indicate the sign (negative or positive) of the value.

sign extend: Fill the unused high order bits of a register with copies of the sign bit in that register.

sign-extension mode (SXM) bit: Bit 10 of status register ST1; enables or disables sign extension in the input shifter. It also differentiates between logic and arithmetic shifts of the accumulator.

single-access RAM: See *SARAM*.

slave phase: See *latch phase*.

software interrupt: An interrupt caused by the execution of an INTR, NMI, or TRAP instruction.

software stack: A program control feature that allows you to extend the hardware stack into data memory with the PSHD and POPD instructions. The stack can be directly stored and recovered from data memory, one word at time. This feature is useful for deep subroutine nesting or protection against stack overflow.

ST0 and ST1: See *status registers ST0 and ST1*.

stack: A block of memory reserved for storing return addresses for subroutines and interrupt service routines. The 'C24x stack is 16 bits wide and eight levels deep.

status registers ST0 and ST1: Two 16-bit registers that contain bits for determining processor modes, addressing pointer values, and indicating various processor conditions and arithmetic logic results. These registers can be stored into and loaded from data memory, allowing the status of the machine to be saved and restored for subroutines.

$\overline{\text{STRB}}$: *External access active strobe*. The 'C24x asserts $\overline{\text{STRB}}$ during accesses to external program, data, or I/O space.

SXM bit: See *sign-extension mode bit (SXM)*.

T

TC bit: *Test/control flag bit.* Bit 11 of status register ST1; stores the results of test operations done in the central arithmetic logic unit (CALU) or the auxiliary register arithmetic unit (ARAU). The TC bit can be tested by conditional instructions.

temporary register (TREG): A 16-bit register that holds one of the operands for a multiply operation; the dynamic shift count for the LACT, ADDT, and SUBT instructions; or the dynamic bit position for the BITT instruction.

TOS: *Top of stack.* Top level of the 8-level last-in, first-out hardware stack.

TREG: See *temporary register (TREG)*.

TTL: *Transistor-to-transistor logic.*

V

vector: See *interrupt vector*.

vector location: See *interrupt vector location*.

W

wait state: A CLKOUT1 cycle during which the CPU waits when reading from or writing to slower external memory.

wait-state generator: An on-chip peripheral that generates a limited number of wait states for a given off-chip memory space (program, data, or I/O). Wait states are set in the wait-state generator control register (WSGR).

\overline{WE} : *Write enable pin.* The 'C24x asserts \overline{WE} to request a write to external program, data, or I/O space.

WSGR: *Wait-state generator control register.* This register, which is mapped to I/O memory, controls the wait-state generator.

X

XF bit: *XF-pin status bit.* Bit 4 of status register ST1 that is used to read or change the logic level on the XF pin.

XF pin: *External flag pin.* A general-purpose output pin whose status can be read or changed by way of the XF bit in status register ST1.

Z

zero fill: A way to fill the unused low or high order bits in a register by inserting 0s.

Summary of Updates in This Document

This appendix provides a summary of the updates in this version of the document. Updates within paragraphs appear in a **bold typeface**.

Rev. B Page:	Rev. C Page:	Change or Add:
-----	-----	<p>Changed the title on the cover and title page to:</p> <p>TMS320F/C240 DSP Controllers, Peripheral Library and Specific Devices.</p> <p>In addition to being revised, this version has been reorganized, and hence, differs significantly from the previous version (SPRU161B). Only major reorganizational changes are noted in this appendix.</p>
2-1	2-1	Chapter 2 in revision <i>B</i> was <i>Event Manager Module</i> . Chapter 2 in revision <i>C</i> is now <i>TMS320F/C240 DSP Controller</i> .
3-1	3-1	Chapter 3 in revision <i>B</i> was <i>Dual 10-Bit Analog-to-Digital Converter (ADC) Module</i> . Chapter 3 in revision <i>C</i> is now <i>System Functions</i> .
4-1	4-1	Chapter 4 in revision <i>B</i> was <i>Serial Communication Interface (SCI) Module</i> . Chapter 4 in revision <i>C</i> is now <i>PLL Clock Module</i> .
5-1	5-1	Chapter 5 in revision <i>B</i> was <i>Serial Peripheral Interface (SPI) Module</i> . Chapter 5 in revision <i>C</i> is now <i>Event Manager</i> .
6-1	6-1	Chapter 6 in revision <i>B</i> was <i>Watchdog and Real-Time Interrupt Module</i> . Chapter 6 in revision <i>C</i> is now <i>Dual 10-Bit Analog-to-Digital Converter (ADC) Module</i> .
7-1	7-1	Chapter 7 in revision <i>B</i> was <i>Flash Memory Module</i> . Chapter 7 in revision <i>C</i> is now <i>Serial Communication Interface (SCI) Module</i> .
8-1	8-1	Chapter 8 in revision <i>B</i> was <i>External Memory Interface</i> . Chapter 8 in revision <i>C</i> is now <i>Serial Peripheral Interface (SPI) Module</i> .
9-1	9-1	Chapter 9 in revision <i>B</i> was <i>Digital I/O Ports</i> . Chapter 9 in revision <i>C</i> is now <i>Watchdog and Real-Time Interrupt Module</i> .
10-1	10-1	Chapter 10 in revision <i>B</i> was <i>PLL Clock Module</i> . Chapter 10 in revision <i>C</i> is now <i>Flash Memory Module</i> .
11-1	11-1	Chapter 11 in revision <i>B</i> was <i>TMS320C240 DSP Controller</i> . Chapter 11 in revision <i>C</i> is now <i>External Memory Interface</i> .
N/A	12-1	Revision <i>B</i> did not have a Chapter 12. Chapter 12 in revision <i>C</i> is <i>Digital I/O Ports</i> .

A

accumulator, definition B-1
ADC control register 1 (ADCTRL1) 7-7
ADC control register 2 (ADCTRL2) 7-10
ADC data register FIFO1 (ADCFIFO1) 7-13
ADC data register FIFO2 (ADCFIFO2) 7-13
ADC, dual
 features 7-2
 operation 7-4 to 7-7
 operation modes 7-4
 overview 7-2
 pin description 7-4
 registers 7-7 to 7-13
ADC1CHSEL bit 7-9
ADC1EN bit 7-8
ADC2CHSEL bit 7-9
ADC2EN bit 7-8
ADCCONRUN bit 7-8
ADCEOC bit 7-8
ADCEVSOC bit 7-10
ADCEXTSOC bit 7-10
ADCFIFO1 (ADC data register FIFO1) 7-13
ADCFIFO1 bit 7-11
ADCFIFO2 (ADC data register FIFO2) 7-13
ADCFIFO2 bit 7-11
ADCIMSTART bit 7-7
ADCINTEN bit 7-8
ADCINTFLAG bit 7-8
ADCPSCALE bit 7-12
ADCSOC bit 7-9
ADCTRL1 (ADC control register 1) 7-7

ADCTRL2 (ADC control register 2) 7-10
address-bit mode protocol 8-21
ADDRESS/IDLE MODE bit 8-21
ADDRESS/IDLE WUP bit 8-9
address-bit mode 8-9, 8-21
 bit format diagram 8-8
 format 8-10
 initialization 8-21
 wake-up 8-15
 when to use 8-13
addressing, bit-reversed indexed B-2
addressing modes, definition B-1
analog inputs, pins 7-4
analog reference—voltage, pins 7-4
analog signal sampling/conversion 7-6
architecture, SCI 8-5
asynchronous SCI 8-7
auxiliary register pointer (ARP) B-2
auxiliary register pointer buffer (ARB) B-2
AVIS bit 11-13

B

baud
 baud rate select registers (SCIHBAUD/SCIL-
 BAUD) 8-25
 generator 8-5
baud rate 9-11
 calculation of 9-11
 maximum value (master) 9-12
 register 9-24
BAUD15–0 bits 8-25
bit-reversed indexed addressing B-2

- block diagram
 - 4-pin option 9-3
 - four-pin option 9-3
 - PLL 4-3
 - SCI module 8-4
 - WD/RTI 5-3
 - break detect 8-28
 - BRKDT bit 8-17, 8-28
 - must-clear situation 8-22
- C**
- calculation of baud rate 9-11
 - maximum 9-12
 - CALU (central arithmetic logic unit), definition B-3
 - CHAR LEN2–0 bits 2-65, 2-66
 - character format 9-10
 - character length 2-65, 2-66, 8-21
 - CKCR0 (clock control register 0) 4-3, 4-14
 - CKCR1 (clock control register 1) 4-3, 4-16
 - CLKMD bits (7–6) 4-14
 - CLKOUT1 signal, definition B-3
 - CLOCK bit 8-14
 - clock control register 0 (CKCR0) 4-3, 4-14
 - clock control register 1 (CKCR1) 4-3 to 4-34
 - CLOCK ENA bit 8-23
 - clock frequencies, PLL 4-8
 - CLOCK PHASE bit 9-20
 - CLOCK POLARITY bit 9-18
 - clocking schemes 9-11, 9-12
 - falling edge with delay 9-12
 - falling edge without delay 9-12
 - rising edge with delay 9-12
 - rising edge without delay 9-12
 - clocks
 - CPUCLK 4-2
 - external 8-23
 - input, optional 8-5
 - internal 8-23
 - optional input 8-5
 - SCICLK 8-23
 - SCICLK port 8-4, 8-5
 - SYSCLK 4-2
 - WDCLK 4-2
 - codec, definition B-3
 - communication control register (SCICCR) 8-20
 - communication format, SCI 8-14
 - communication modes, multiprocessor 8-21
 - compare control register (COMCON) 6-51
 - compare unit interrupts 6-58
 - compare unit registers 6-51
 - compare control register (COMCON) 6-51
 - full compare action control register (ACTR) 6-55
 - simple compare action control register (SACTR) 6-57
 - compare unit reset 6-58
 - compare units 6-47
 - full compare units 6-48
 - interrupts 6-58
 - registers 6-51
 - reset 6-58
 - simple compare units 6-47
 - configuration control register 9-18
 - connections, slave – master (4-pin) 9-7
 - control bits
 - ADDRESS/IDLE MODE 8-21
 - Baud15–0 8-25
 - CHAR LEN2–0 2-65, 2-66
 - CLOCK ENA 8-23
 - PARITY 8-20
 - PARITY ENABLE 2-65, 8-20
 - RX ERR INT ENA 8-22
 - RX/BK INT ENA 8-26
 - RXENA 8-24
 - SCI CHAR2–0 8-21
 - SCI ENA 8-20
 - STOP BITS 2-65, 2-69, 2-70, 2-71, 2-72, 2-73, 2-74, 2-75, 8-20
 - SW RESET 8-22
 - flags affected* 8-22
 - TX INT ENA 8-26
 - TXENA 8-24
 - TXRDY 8-26
 - TXWAKE 8-23
 - control bits of SPI 9-17
 - control register
 - ADC control register 1 (ADCTRL1) 7-7
 - ADC control register 2 (ADCTRL2) 7-10
 - ADC data register FIFO1 (ADCFIFO1) 7-13
 - ADC data register FIFO2 (ADCFIFO2) 7-13
 - control register 1 (SCICTL1) 8-22
 - control register file 5-11
 - control registers 5-4
 - ADCFIFO1 (ADC data register FIFO1) 7-13

ADCFIFO2 (ADC data register FIFO2) 7-13
 ADCTRL1 (ADC control register 1) 7-7
 ADCTRL2 (ADC control register 2) 7-10
 address configuration 5-5
 CKCR0 (clock control register 0) 4-3, 4-14
 CKCR1 (clock control register 1) 4-3, 4-16
 clock control register 0 (CKCR0) 4-3, 4-14
 clock control register 1 (CKCR1) 4-3, 4-16
 memory map 5-5
 RTI Control register (RTICR) 5-4
 RTI control register (RTICR) 5-14
 RTI counter register (RTICNTR) 5-4, 5-12
 RTICNTR (RTI counter register) 5-4, 5-12
 RTICR (RTI control register) 5-4, 5-14
 SCI 8-5
 SCICTL2 (SCI control register 2) 8-26
 SPI 9-4
 SPI port control register 1 (SPIPC1) 9-29
 SPI port control register 2 (SPIPC2) 9-31
 SPI priority control register (SPIPRI) 9-33
 SPInBRR 9-24
 SPInBUF 9-27
 SPInCRR 9-18
 SPInCTL 9-20
 SPInDAT 9-28
 SPInEMU 9-26
 SPInSTS 9-23
 SPIPC1 (SPI port control register 1) 9-29
 SPIPC2 (SPI port control register 2) 9-31
 SPIPRI (SPI priority control register) 9-33
 wait-state generator control register
 (WSGR) 11-12
 WD Control register (WDCR) 5-4
 WD counter register (WDCNTR) 5-4, 5-13
 WD key register (WDKEY) 5-4
 WD reset key register (WDKEY) 5-13
 WD timer control register (WDCR) 5-16
 WDCNTR (WD counter register) 5-4, 5-13
 WDCR (WD control register) 5-4
 WDCR (WD timer control register) 5-16
 WDKEY (WD key register) 5-4
 WDKEY (WD reset key register) 5-13
 WSGR (wait-state generator control register) 11-12
 converter, ADC, dual 7-2
 CPU, definition B-4
 CPUCLK 4-2

D

D0–D15 (external data bus), definition B-4
 D7–D0 (data values) bits 5-12, 5-13
 Data and Direction Registers 12-2
 data format 9-10
 SCI 8-8
 data memory select (DS) signal 11-5
 data receipt, emulation 8-30
 data transfer example 9-15
 4-pin option 9-16
 data word size 8-2
 dead-band timer control register (DBTCON) 6-61
 device reset 2-31
 diagrams
 memory interface timing 11-10
 waveforms 11-10
 Digital I/O Ports, overview 12-2
 DIV1 and DIV2 pins B-5
 DS (data memory select) signal 11-5
 DSWS bit 11-13
 dual-access RAM (DARAM) B-4

E

emulation
 data-receipt 8-30
 emulation data buffer register (SCIRXEMU) 8-30
 suspension 8-33
 emulation buffer register 9-26
 enabling
 communication 8-20
 interrupts 8-26
 parity 2-65, 8-20
 receiver 8-22
 ERCVD 7–0 bits 9-26
 error flags
 BRKDT (break detect) bit 8-28
 FE (framing error) bit 8-28
 OE (overrun) bit 8-28
 PE (parity error) bit 8-28
 EV interrupt register, addresses 6-10
 even parity 8-20
 event manager, register addresses 6-8

- event manager (EV) 6-2
 - block diagram 6-3
 - functional blocks 6-2
 - interrupts 6-6
 - overview 6-2
 - pins 6-4
 - power drive protection 6-5
 - registers 6-6

- external memory interface
 - key signals 11-2, 11-5
 - overview 11-2

- external pins, illustration 8-4

F

- FE bit (framing error flag) 8-28

- features

- real-time interrupt (RTI) 5-2
 - Watchdog (WD) 5-2

- flash

- bit programming 10-3
 - EEPROM
 - module register addresses* 10-7
 - overview* 10-2
 - erasing 10-5
 - registers 10-7
 - segment control register 10-8
 - writing 10-6

- flash EEPROM, overview 10-2

- flash segment control register 10-7

- flash test register (TST) 10-10

- format of character 9-10

- formula

- digital result 7-4
 - prescale sampler 7-6

- formulas, SCI baud rate 8-18, 8-25

- four-pin option

- block diagram 9-3
 - features 9-2

- framing error 8-28

- free-running counter 5-6

- freezing flag content 8-22

- full compare action control register (ACTR) 6-55

- full compare unit register, addresses 6-9

- full compare units

- block diagram 6-49
 - functional blocks 6-48

- inputs 6-49

- operation modes 6-49

- outputs 6-49

- PWM circuits 6-59

- full-duplex mode 8-2

G

- general purpose (GP) timer 6-11

- 32-bit timer 6-16

- block diagram 6-12

- clock 6-16

- compare operation 6-34

- compare output 6-15

- compare registers 6-13

- double buffering* 6-14

- control of operation 6-13

- control register (GPTCON) 6-13

- control registers 6-40

- counting direction 6-15

- counting operation 6-19

- functional blocks 6-11

- generation of compare output 6-45

- generation of PWM output 6-45

- inputs 6-12

- interrupts 6-18

- outputs 6-13

- overview 6-11

- period register 6-14

- double buffering* 6-14

- reset 6-46

- synchronization 6-17

- generator, wait-state

- description 11-12

- ready signal 11-12

- GP timer compare operation 6-34

- asymmetric waveform generation 6-35

- asymmetric/symmetric waveform generator 6-34

- compare/PWM transition 6-34

- symmetric waveform generation 6-36

- GP timer control register (GPTCON) 6-13, 6-42

- GP timer control register (TxCON) 6-40

- GP timer control registers 6-40

- GP timer counting operation 6-19

- continuous-up counting mode 6-22

- continuous-up/down counting mode 6-31

- directional-up/down counting mode 6-25

- single-up counting mode 6-19

- single-up/down counting mode 6-28

stop/hold mode 6-19
 GP timer register, addresses 6-8
 GP timer reset 6-46

H

hardware interrupts, nonmaskable external,
 RS 2-31
 hardware reset 2-31
 effects 2-33 to 2-34
 hardware stack, overflow, ISRs within ISRs 2-58

I

I/O pins
 Four-pin option 9-2
 SPICLK 9-7
 SPInCLK 9-11
 SPInSOMI 9-8
 SPInSTB 9-8
 SPISOMI 9-7

idle periods example
 indicate block separation 8-10
 no significance 8-13

idle-line wakeup mode 8-10, 8-21
 bit format diagram 8-8
 description 8-9

idle-line mode protocol 8-21

IFR 2-64 to 2-76

IMR 2-66 to 2-76

initialization examples 9-34

initialization upon reset 9-14

initializing SCI state machine 8-22

input divide-by-2 control bit, PLL 4-7

instruction register (IR), definition B-8

INT1 interrupt
 priority 2-29
 vector location 2-29

INT10 interrupt, vector location 2-29

INT11 interrupt, vector location 2-29

INT12 interrupt, vector location 2-29

INT13 interrupt, vector location 2-29

INT14 interrupt, vector location 2-29

INT15 interrupt, vector location 2-29

INT16 interrupt, vector location 2-29

INT2 interrupt
 priority 2-29
 vector location 2-29

INT20 interrupt, vector location 2-29

INT21 interrupt, vector location 2-29

INT22 interrupt, vector location 2-29

INT23 interrupt, vector location 2-30

INT24 interrupt, vector location 2-30

INT25 interrupt, vector location 2-30

INT26 interrupt, vector location 2-30

INT27 interrupt, vector location 2-30

INT28 interrupt, vector location 2-30

INT29 interrupt, vector location 2-30

INT3 interrupt
 priority 2-29
 vector location 2-29

INT30 interrupt, vector location 2-30

INT31 interrupt, vector location 2-30

INT8 interrupt, vector location 2-29 to 2-31

INT9 interrupt, vector location 2-29

interrupt
 conditions
break 8-27
BRKDT bit 8-27
receive buffer loaded 8-27
RXBUF RDY flag 8-27
SCITXBUF contents transferred 8-26
transmit buffer ready for data 8-26
TXBUF RDY flag 8-26
 definitions B-8
 enabling
break 8-26
receive buffer 8-26
transmit buffer 8-26
transmit shift register 8-26
 priority designation 8-33

interrupt flag bit 9-9

interrupt flag register (IFR) 2-64 to 2-76

interrupt latency, definition B-9

interrupt mask register (IMR) 2-66 to 2-76

interrupt service routines (ISRs)
 definition B-9
 ISRs within ISRs 2-58

interrupts 2-27 to 2-63, 9-8
 hardware
nonmaskable external, RS 2-31
priorities 2-50
'C240 2-29, 2-44

- IMR register 2-66
- interrupt mask register 2-66
- interrupt service routines (ISRs), ISRs within ISRs 2-58
- latency 2-59 to 2-60
 - after execution of RET* 2-60
 - during execution of CLRC INTM* 2-60
 - factors* 2-59 to 2-60
 - minimum latency* 2-59
- masking, interrupt mask register (IMR) 2-66 to 2-76
- nonmaskable, reset, effects 2-33 to 2-34
- pending, interrupt flag register (IFR) 2-64 to 2-76
- saving data 2-57
- introduction
 - TMS320 family overview 1-2
 - to control registers 9-17
 - to operation 9-6
- IR (instruction register), definition B-8
- ISR, ISRs within ISRs 2-58
- ISR (interrupt service routine), definition B-9
- ISWS bit 11-13

L

- latch phase of CPU cycle B-9
- latency, interrupt 2-59 to 2-60
 - after execution of RET* 2-60
 - during execution of CLRC INTM* 2-60
 - factors* 2-59
 - minimum latency* 2-59
- logic phase of CPU cycle B-10
- low-power modes, PLL 4-10 to 4-20

M

- master mode, 3-pin option 9-7
- MASTER/SLAVE, bit 9-21
- master/slave, connection, 4-pin 9-7
- MCF (multiprocessor communication format) 8-10, 8-13
- memory interface timing, diagrams 11-10
- memory map 5-5, 5-11
 - SCI 8-6
- modes
 - lower power 4-10

- LPMODE 0 4-12
- LPMODE 1 4-12
- LPMODE 2 4-12
- LPMODE 3 4-13

- modifying SPI configuration 9-14
- multiplication ratio select bits, PLL 4-7
- multiprocessor communication 8-21
- multiprocessor communication format (MCF) 8-10, 8-13
- multiprocessor communications, SCI 8-9
- multiprocessor modes 8-9

N

- next program address register (NPAR), definition B-11
- NMI instruction, vector location 2-29
- NMI interrupt, vector location 2-29
- nonmaskable interrupts, external, RS 2-31
- nonreturn-to-zero format 8-2
- NPAR (next program address register), definition B-11

O

- odd parity 8-20
- OE (output enable) 11-4
- OE (output enable) signal 11-4
- OE bit (overrun flag) 8-28
- operation
 - ADC, dual 7-4 to 7-7
 - control register 9-20
 - introduction 9-6
 - modes
 - master, 3-pin option* 9-7
 - slave, three-pin option* 9-8
 - WD/RTI timers 5-6
- operation modes 8-7
 - clock-in mode 4-6
 - oscillator mode 4-6
- operation of SPI 9-6
- Output Control Registers 12-2
- output enable (OE) pin 11-4
- output enable (OE) signal 11-4
- overrun error 8-28
- OVERRUN INT ENA bit 9-9, 9-20
- overview
 - ADC, dual 7-2

external memory interface 11-2
 SCI 8-2
 SPI 9-2
 TMS320 family 1-2

P

PAR (program address register), definition B-12
 PARITY bit 8-20
 PARITY ENABLE bit 2-65, 8-20
 parity error 8-28
 PE bit (parity error) 8-28
 physical description, SPI 9-2
 physical description, SCI 8-2
 pin description, ADC, dual 7-4
 pin description, PLL 4-5
 pin SCIRXD, receive example 8-15
 pins
 analog input 7-4
 OE (output enable) 11-4
 output enable (OE) 11-4
 SPISTB 9-2
 pins, external
 illustration 8-4
 SCICLK 8-14
 SCIRXD 8-4, 8-5
 control bits 8-31
 SCITXD 8-4, 8-5
 control bits 8-31
 pins, PLL
 OSCBYP 4-5
 XTAL1/CLKIN 4-5
 XTAL2 4-5
 PLL 4-2 to 4-4
 block diagram 4-3
 control registers 4-14 to 4-29
 frequency selection
 CPUCLK 4-7 to 4-14
 SYSCLK 4-8
 operation 4-5 to 4-10
 operation modes 4-6 to 4-12
 oscillator 4-6
 overview 4-2 to 4-4
 pin description 4-5
 startup 4-9 to 4-18
 PLLDIV2 bit 4-7
 PLLDIV2 bit (3) 4-16

PLLFB bits 4-7
 PLLFB bits (2–0) 4-17
 PLLOCK bits (5–4) 4-14
 PLLPM bits (3–2) 4-15
 PLLPS bit (0) 4-8, 4-15
 port control register 1 9-29
 port control register 2 9-31
 port interrupts, SCI 8-17
 power, lowering requirements 3-10
 power-down mode 3-10
 prescale select bit (PLLPS) 4-8
 prescaler values, list 7-6
 priority control register 9-33
 priority control register (SCIPRI) 8-33
 program address register (PAR), definition B-12
 program control
 interrupts 2-27 to 2-63
 power-down mode 3-10
 program select (PS) signal 11-4
 programmable dead-band unit 6-61
 dead-band timer control register
 (DBTCON) 6-61
 protocols
 address-bit mode 8-21
 idle-line mode 8-21
 PS (program select) signal 11-4
 PSWS bit 11-13
 PWM circuits, block diagram 6-59
 PWM circuits associated with full compare
 units 6-59

Q

quadrature encoder pulse (QEP) decoding circuit
 register, addresses 6-9

R

RCVD 7–0 bits 9-27
 ready signal 11-12
 real-time interrupt (RTI)
 block diagram 5-3
 RTI timer, features 5-2
 selections 5-15
 real-time interrupt (RTI) 5-1 to 5-20
 overview 5-1 to 5-20

- WD/RTI module 5-1 to 5-20
- receive signals (illustration) 8-15
- receive/transmit mode, full-duplex 8-2
- receiver
 - address-bit wakeup 8-12, 8-15
 - data buffer registers
 - SCIRXBUF (normal operation) 8-29
 - SCIRXEMU (emulation operation) 8-29
 - data emulation 8-30
 - idle-line wakeup 8-10
 - interrupt priority control 8-33
 - major components 8-5
 - receiver data buffer register (SCIRXBUF) 8-5
 - RXSHF shift register 8-5
- RECEIVER_OVERRUN flag bit 9-10, 9-23
- receiver status register (SCIRXST) 8-27
 - bit association figure 8-29
- registers
 - ADC control register 1 (ADCTRL1) 7-7
 - ADC control register 2 (ADCTRL2) 7-10
 - ADC data register FIFO1 (ADCFIFO1) 7-13
 - ADC data register FIFO2 (ADCFIFO2) 7-13
 - ADCFIFO1 (ADC data register FIFO1) 7-13
 - ADCFIFO2 (ADC data register FIFO2) 7-13
 - ADCTRL1 (ADC control register 1) 7-7
 - ADCTRL2 (ADC control register 2) 7-10
 - CKCR0 (clock control register 0) 4-3, 4-14
 - CKCR1 (clock control register 1) 4-3, 4-16
 - clock control register 0 (CKCR0) 4-3, 4-14
 - clock control register 1 (CKCR1) 4-3, 4-16
 - interrupt flag register (IFR) 2-64 to 2-76
 - interrupt mask register (IMR) 2-66 to 2-76
 - RTI control register (RTICR) 5-14
 - RTI counter register (RTICNTR) 5-12
 - RTICNTR (RTI counter register) 5-12
 - RTICR (RTI control register) 5-14
 - SCICTL1 (control register 1) 8-22
 - SCICTL2 (control register 2) 8-26
 - SCIHBAUD, SCILBAUD (baud rate) 8-25
 - SCICCR (communication control) 8-20
 - SCIRXBUF (receiver data buffer) 8-29
 - SCIRXEMU (receiver data, emulation) 8-29
 - SCIRXST (receiver status) 8-27
 - bit association figure 8-29
 - SCITXBUF (transmit data buffer) 8-12, 8-30
 - SPI port control register 1 (SPIPC1) 9-29
 - SPI port control register 2 (SPIPC2) 9-31
 - SPI priority control register (SPIPRI) 9-33
 - SPIBRR (SPI baud rate) 9-4
 - SPIBUF 9-2
 - SPIBUF (SPI receive buffer) 9-4
 - SPICCR (SPI configuration control) 9-4
 - SPICTL (SPI operation control) 9-4
 - SPIDAT 9-2
 - SPIDAT (SPI data register) 9-4
 - SPIEMU (SPI emulation buffer) 9-4
 - SPIInBRR (SPI baud rate) **9-24**
 - SPIInBUF (SPI receive buffer) **9-27**
 - SPIInCCR (SPI configuration control) **9-18**
 - SPIInCTL (SPI operation control) **9-20**
 - SPIInDAT (SPI data register) **9-28**
 - SPIInEMU (SPI emulation buffer) **9-26**
 - SPIInPC2 (SPI port control register 2) 9-4
 - SPIInPRI (SPI priority register) 9-4
 - SPIInSTS (SPI status) **9-23**
 - SPIPC1 (SPI port control register 1) 9-4, **9-29**
 - SPIPC2 (SPI port control register 2) **9-31**
 - SPIPRI (SPI priority control register) **9-33**
 - SPISTS (SPI status) 9-4
 - system control (SYSCR) 3-6
 - system interrupt vector register (SYSIVR) 3-9, A-8
 - system status (SYSSR) 3-7
 - TXSHF 8-12
 - wait-state generator control register (WSGR) 11-12
 - WD counter register (WDCNTR) 5-13
 - WD reset key register (WDKEY) 5-13
 - WD timer control register (WDCR) 5-16
 - WDCNTR (WD counter register) 5-13
 - WDCR (WD timer control register) 5-16
 - WDKEY (WD reset key register) 5-13
 - WSGR (wait-state generator control register) 11-12
 - WUT 8-12
- reset 2-31, 5-7
 - effects 2-33 to 2-34
 - priority 2-29
 - vector location 2-29
- reset configuration of SPI 9-14
- resetting the module 8-22
- RS 2-31
 - effects 2-33 to 2-34
 - priority 2-29
 - vector location 2-29
- RS-232-C communications 8-21
- RTI control register (RTICR) 5-4, 5-14
- WD timer control register (WDCR) 5-16

RTI counter register (RTICNTR) 5-4, 5-12
 RTI ENA bit 5-14
 RTI FLAG bit 5-14
 RTI prescale select bits (RTICR register) 5-14
 RTI timer 5-2
 enabling and disabling 5-9
 free-running counter 5-9
 overflow flag 5-10
 prescale select 5-9
 RTI prescale select bits 5-14
 RTICNTR (RTI counter register) 5-4, 5-12
 RTICR (RTI control register) 5-4, 5-14
 WDCR (WD timer control register) 5-16
 RX ERR INT ENA bit 8-22
 RX ERROR bit 8-27
 RX/BK INT ENA bit 8-26
 RXENA bit 8-24
 receive example 8-15
 RXRDY bit 8-17, 8-27
 receive example 8-15
 RXSHF register, description 8-5
 RXWAKE bit 8-29

S

sample clock frequencies, list 7-6
 SARAM (single-access RAM), definition B-14
 SCI
 architecture 8-5
 communication format 8-14
 control registers 8-5
 data format 8-8
 memory map 8-6
 multiprocessor communication 8-9
 physical description 8-2
 port interrupts 8-17
 SCI, overview 8-2
 SCI (serial communications interface) registers 8-19
 overview 8-19
 SCI baud rate formulas 8-18, 8-25
 SCI block diagram 8-4
 SCI CHAR2–0 bits 8-21
 SCI control register 2 (SCICTL2) 8-26
 SCI ENA bit 8-20

SCI ESPEN bit 8-33
 SCI port control register 2 (SCIPC2) 8-31
 SCICCR register (communication control) 8-20
 SCICLK pin 8-5
 SCICTL1 register (control register 1) 8-22
 SCICTL2 register (control register 2) 8-26
 SCIHBAUD register (baud rate) 8-25
 SCILBAUD register (baud rate) 8-25
 SCIPC2 register (port control 2) 8-31
 SCIPRI register (priority control) 8-33
 SCIRX PRIORITY bit 8-33
 SCIRXBUF register 8-30
 SCIRXD DATA DIR bit 8-32
 SCIRXD DATA IN bit 8-31
 SCIRXD DATA OUT bit 8-31
 SCIRXD FUNCTION bit 8-32
 SCIRXD pin 8-4, 8-5
 control bits 8-31
 current value 8-31
 function selection 8-32
 output value 8-31
 receive example 8-15
 SCIRXEMU register 8-30
 SCIRXST register (receiver status) 8-27
 bit association figure 8-29
 SCITX PRIORITY bit 8-33
 SCITXBUF register 8-30
 SCITXD DATA DIR bit 8-31
 SCITXD DATA IN bit 8-31
 SCITXD DATA OUT bit 8-31
 SCITXD FUNCTION bit 8-31
 SCITXD pin 8-4, 8-5
 control bits 8-31
 current value 8-31
 data direction 8-31
 function selection 8-31
 output value 8-31
 screen updates, register usage 8-30
 SDAT 7–0 bits 9-28
 serial communications interface (SCI) registers
 overview 8-19
 summary 8-19
 serial data register 9-28
 serial input buffer register 9-27
 servicing the watchdog 5-7
 signal, program select (PS) signal 11-4

- signals
 - data memory select (DS) 11-5
 - DS (data memory select) 11-5
 - for external data memory interface 11-5
 - for external program memory interface 11-2
 - OE (output enable) 11-4
 - output enable (OE) 11-4
 - ready 11-12
- simple compare action control register (SACTR) 6-57
- simple compare unit register, addresses 6-9
- simple compare units
 - block diagram 6-48
 - functional blocks 6-47
- single-access RAM (SARAM), definition B-14
- slave mode, three-pin option 9-8
- SLEEP bit, example 8-11
- sleep bit 8-24
- software reset 8-22
- SPI
 - control registers 9-4
 - overview 9-2
 - physical description 9-2
- SPI bit rate 6–0 bits 9-24
- SPI CHAR2–0 bit 9-19
- SPI ESPEN bit 9-33
- SPI INT ENA bit 9-9, 9-21
- SPI INT FLAG bit 9-24
- SPI port control register 1 (SPIPC1) 9-29
- SPI port control register 2 (SPIPC2) 9-31
- SPI PRIORITY bit 9-33
- SPI priority control register (SPIPRI) 9-33
- SPI SW RESET bit initialization 9-14
- SPIBRR register, features 9-4
- SPIBUF (SPI receive buffer), four-pin option 9-2
- SPIBUF register, features 9-4
- SPICCR register, features 9-4
- SPICLK, signal options 9-13, 9-22
- SPICLK DATA DIR bit 9-30
- SPICLK DATA IN bit 9-30
- SPICLK DATA OUT bit 9-30
- SPICLK FUNCTION bit 9-30
- SPICTL register, features 9-4
- SPIDAT, four-pin option 9-2
- SPIDAT register, features 9-4
- SPIEMU register, features 9-4
- SPInBRR register 9-24
 - calculation of baud rate 9-11
 - clocking affect 9-14
 - operation 9-7
- SPInBUF register
 - description 9-27
 - operation 9-7
- SPInCCR register, description 9-18
- SPInCTL register, description 9-20
- SPInDAT register
 - description 9-28
 - operation 9-7, 9-8
- SPInEMU register, description 9-26
- SPInPC2 register, features 9-4
- SPIPC2 (SPI port control register 2) 9-31
- SPInPRI register, features 9-4
- SPInSTS register, description 9-23
- SPIPC1 (SPI port control register 1) 9-29
- SPIPC1 register, features 9-4
- SPIPRI (SPI priority control register) 9-33
- SPISIMO DATA DIR bit 9-31
- SPISIMO DATA IN bit 9-31
- SPISIMO DATA OUT bit 9-31
- SPISIMO FUNCTION bit 9-31
- SPISOMI DATA DIR bit 9-32
- SPISOMI DATA IN bit 9-31
- SPISOMI DATA OUT bit 9-31
- SPISOMI FUNCTION bit 9-32
- SPISTB DATA DIR bit 9-30
- SPISTB DATA IN bit 9-29
- SPISTB DATA OUT bit 9-29
- SPISTB FUNCTION bit 9-29
- SPISTB pin 9-2
- SPISTS register, features 9-4
- stack, overflow, ISRs within ISRs 2-58
- startup, PLL 4-9 to 4-18
- state machine initialization 8-22
- status and control bits 8-33
 - BRKDT (break flag) 8-28
 - CLOCK 8-14
 - FE (framing error flag) 8-28
 - OE (overrun flag) 8-28
 - PE (parity error) 8-28
 - RX ERROR 8-27
 - RXRDY 8-27

- RXWAKE 8-29
 - SCI ESPEN 8-33
 - SCIRXD DATA DIR 8-32
 - SCIRXD DATA IN 8-31
 - SCIRXD DATA OUT 8-31
 - SCIRXD FUNCTION 8-32
 - SCITX PRIORITY 8-33
 - SCITXD DATA DIR 8-31
 - SCITXD DATA IN 8-31
 - SCITXD DATA OUT 8-31
 - SCITXD FUNCTION 8-31
 - SLEEP 8-11, 8-12, 8-24
 - TX EMPTY 8-26
 - TXWAKE 8-12
 - WUT 8-11
 - status register 9-23
 - stop bits (1 or 2) 2-65, 2-69, 2-70, 2-71, 2-72, 2-73, 2-74, 2-75, 8-2, 8-20
 - suspend-free bit 7-7
 - suspend-soft bit 7-7
 - SW RESET bit 8-22
 - flags affected 8-22
 - SYSCLK 4-2
 - system control register (SYSCR) 3-6
 - system interrupt vector register (SYSIVR) 3-9, A-8
 - system status register (SYSSR) 3-7
- T**
- TALK bit 9-21
 - TMS320 family 1-2 to 1-6
 - advantages 1-2
 - development 1-2
 - history 1-2
 - overview 1-2
 - TMS320C24x, features
 - CPU 1-8
 - emulation 1-9
 - event manager 1-9
 - instruction set 1-8
 - memory 1-8
 - power 1-8
 - program control 1-8
 - speed 1-9
 - TMS370C16, watchdog setup example 5-18 to 5-20
 - transmission steps
 - address-bit mode 8-13
 - idle-line mode 8-12
 - transmit buffer
 - interrupt enable 8-26
 - ready flag 8-26
 - transmit data, illustration 8-16
 - transmit feature 8-23
 - transmit shift register
 - interrupt enable 8-26
 - register empty flag 8-26
 - transmit signals (illustration) 8-16
 - transmit/receive mode, full-duplex 8-2
 - transmitter
 - address-bit wakeup 8-12
 - address-bit wakeup 8-16
 - idle-line wakeup 8-10
 - interrupt priority control 8-33
 - major components 8-5
 - transmit buffer register (SCITXBUF) 8-5
 - TXSHF shift register 8-5
 - when to use address-bit mode 8-13
 - TRAP instruction, vector location 2-29
 - TX EMPTY bit 8-26
 - transmit example 8-16
 - TX INT ENA bit 8-26
 - TXENA bit 8-24
 - transmit example 8-16
 - TXRDY bit 8-17, 8-26
 - transmit example 8-16
 - TXSHF register, description 8-5
 - TXWAKE bit 8-11, 8-12, 8-23
 - transmission use 8-12, 8-13
- V**
- vector locations 2-50
- W**
- wait states, definition B-16
 - wait-state generator
 - description 11-12
 - ready signal 11-12
 - wait-state generator control register (WSGR) 11-12
 - wake up temporary (WUT) 8-11

- wakeup condition 8-29
- wakeup modes
 - address bit 8-12, 8-15
 - receiver* 8-15
 - transmitter* 8-16
 - idle line 8-10
 - receiver, transmitter* 8-10
- watchdog (WD) 5-1 to 5-20
 - block diagram 5-3
 - control registers 5-4
 - overflow selections 5-17
 - overview 5-1 to 5-20
 - WD timer 5-1 to 5-20
 - features* 5-2
 - WD/RTI module 5-1 to 5-20
- Watchdog Counter Clock, PLL 4-9
- waveforms, diagrams 11-10
- WD control register (WDCR) 5-4
- WD counter register (WDCNTR) 5-4, 5-13
- WD FLAG bit 5-16
- WD key register (WDKEY) 5-4
- WD reset key register (WDKEY) 5-13
- WD timer 5-2, 5-6 to 5-8
 - check bit logic 5-8
 - disable 5-8
 - features 5-2
 - free-running counter 5-6
 - initialization 5-8
 - operation 5-6
 - reset 5-7, 5-8
 - servicing the watchdog 5-7
 - Setup 5-8
 - WD prescale select 5-6
- WD timer and RTI module, avoiding premature reset 5-8
- WD/RTI module
 - block diagram 5-3
 - control register file 5-11
 - control registers 5-11 to 5-17
 - memory map 5-11
 - TMS370C16 setup routine 5-18 to 5-20
- WDCHK0 bit 5-16
- WDCHK1 bit 5-16
- WDCHK2 bit 5-16
- WDCLK 4-2, 4-9
- WDCNTR (WD counter register) 5-4, 5-13
- WDCR (WD control register) 5-4
- WDDIS bit 5-16
- WDKEY (WD key register) 5-4
- WDKEY (WD reset key register) 5-13
- WDPS bits 5-17
- write address register (WADRS) 10-10
- write data register (WDATA) 10-10
- WSGR (wait-state generator control register) 11-12
- WUT flag (wake up temporary) 8-11



XDS emulator 9-33